

1xEV-DO Guide

Agilent Technologies PSA Series and VSA E4406A

Option 204

This manual provides documentation for the following instruments:

Transmitter Tester:

E4406A

Spectrum Analyzers:

E4440A (3 Hz - 26.5 GHz)

E4443A (3 Hz - 6.7 GHz)

E4445A (3 Hz - 13.2 GHz)

E4446A (3 Hz - 44.0 GHz)

E4448A (3 Hz - 50.0 GHz)



Agilent Technologies

Manufacturing Part Number: E4406-90237

Supersedes E4440-90119 and E4406-90229

Printed in USA

December 2002

© Copyright 1999 - 2002 Agilent Technologies, Inc.

The information contained in this document is subject to change without notice.

Agilent Technologies makes no warranty of any kind with regard to this material, including but not limited to, the implied warranties of merchantability and fitness for a particular purpose. Agilent Technologies shall not be liable for errors contained herein or for incidental or consequential damages in connection with the furnishing, performance, or use of this material.

1. Understanding 1xEV-DO	
What Is the 1xEV-DO System?	30
What Does the Agilent PSA Series and VSA E4406A Option 204 Do?	35
Other Sources of Measurement Information	36
2. Getting Started	
Instrument Front Panel Highlights	38
Making a Measurement	41
Start Making Channel Power Measurements	42
Start Making Intermodulation Measurements	44
Start Making Power versus Time Measurements	47
Start Making Spurious Emissions & ACP Measurements	50
Start Making Occupied Bandwidth Measurements	53
Start Making Code Domain Measurements	55
Start Making Modulation Accuracy (Composite Rho) Measurements	58
Start Making QPSK EVM Measurements	62
Start Making Power Stat CCDF Measurements	65
If You Have a Problem	67
3. Setting Up the Mode	
1xEV-DO Mode	70
1xEV-DO Measurement Key Flow	78
Installing Optional Measurement Personalities	114
4. Making Measurements	
1xEV-DO Measurements	122
Preparing for Measurements	123
Making the Channel Power Measurement	130
Making the Intermodulation Measurement	135
Making the Power versus Time Measurement	141
Making the Spurious Emissions and ACP Measurement	150
Making the Occupied Bandwidth Measurement	166
Making the Forward Link Code Domain Measurement	170
Making the Reverse Link Code Domain Measurement	181
Making the Forward Link Modulation Accuracy (Composite Rho) Measurement	197
Making the Reverse Link Modulation Accuracy (Composite Rho) Measurement	214
Making the QPSK EVM Measurement	226
Making the Power Stat CCDF Measurement	236
Making the Spectrum (Frequency Domain) Measurement	241
Making the Waveform (Time Domain) Measurement	254
5. Programming Commands	
SCPI Command Subsystems	266
Programming Command Compatibility Across Model Numbers and Across Modes	267
CALCulate Subsystem	272
CONFigure Subsystem	316

Contents

DISPlay Subsystem317
FETCh Subsystem331
FORMat Subsystem332
INITiate Subsystem334
INSTrument Subsystem336
MEASure Group of Commands339
READ Subsystem410
SENSE Subsystem411
TRIGger Subsystem536

List of Commands

DISPlay:TRHO:VIEW POLar ERRor TABLE	328
DISPlay:TRHO:VIEW?	328
:CALCulate:CDPower:ASET:THReshold <numeric>	272
:CALCulate:CDPower:ASET:THReshold?	272
:CALCulate:CDPower:CHANnel:TYPE DATA MAC PILOT	272
:CALCulate:CDPower:CHANnel:TYPE?	272
:CALCulate:CDPower:IQ:COMBined[:STATe]OFF ON 0 1	272
:CALCulate:CDPower:IQ:COMBined[:STATe]?	273
:CALCulate:CDPower:SWEep:OFFSet <float>	273
:CALCulate:CDPower:SWEep:OFFSet <integer>	273
:CALCulate:CDPower:SWEep:OFFSet?	273
:CALCulate:CDPower:SWEep:TIME <float>	274
:CALCulate:CDPower:SWEep:TIME <integer>	274
:CALCulate:CDPower:SWEep:TIME?	274
:CALCulate:CDPower:TYPE ABSolute RELative	275
:CALCulate:CDPower:TYPE:DATA OPSK QAM QPSK	275
:CALCulate:CDPower:TYPE:DATA?	275
:CALCulate:CDPower:TYPE?	275
:CALCulate:CDPower:WCODe:ORDer BREVerse	276
:CALCulate:CDPower:WCODe:ORDer?	276
:CALCulate:CDPower:WCODe[:NUMBer] <integer>	275
:CALCulate:CDPower:WCODe[:NUMBer]?	275
:CALCulate:CLIMits:FAIL?	281
:CALCulate:DATA<n>:COMPRESS? BLOCK CFIT MAXimum MEAN MINimum RMS SAM- Ple SDEViation [,<soffset>,<length>,<roffset>,<rlimit>]]]	281
:CALCulate:DATA<n>:PEAKs? <threshold>,<excursion>[,<AMPLitude FREQuency TIME]	288
:CALCulate:DATA[n]?	281
:CALCulate:OBWidth:LIMit:FBLimit <freq>	302
:CALCulate:OBWidth:LIMit:FBLimit?	302
:CALCulate:OBWidth:LIMit:STATe OFF ON 0 1	302
:CALCulate:OBWidth:LIMit:STATe?	302

List of Commands

:CALCulate:OBW:LIMit:FBLimit <freq>302
:CALCulate:OBW:LIMit:FBLimit?302
:CALCulate:OBW:LIMit[:TEST] OFF ON 0 1.302
:CALCulate:OBW:LIMit[:TEST]?302
:CALCulate:PStatistic:StORe:REfERence ON 1304
:CALCulate:RHO:ASeT:ThReShoLd <numeric>305
:CALCulate:RHO:ASeT:ThReShoLd:AUTO OFF ON 0 1.305
:CALCulate:RHO:ASeT:ThReShoLd:AUTO?305
:CALCulate:RHO:ASeT:ThReShoLd?305
:CALCulate:RHO:IQOFfset:INCLude OFF ON 0 1305
:CALCulate:RHO:IQOFfset:INCLude?305
:CALCulate:RHO:LIMit:DATA[ACTive][:UPPer]dB306
:CALCulate:RHO:LIMit:DATA[:ACTive][:LOWer] <float>306
:CALCulate:RHO:LIMit:DATA[:ACTive][:LOWer]?306
:CALCulate:RHO:LIMit:DATA[:ACTive][:UPPer] <float>306
:CALCulate:RHO:LIMit:DATA[:ACTive][:UPPer]?306
:CALCulate:RHO:LIMit:FREQuency <numeric>.306
:CALCulate:RHO:LIMit:FREQuency?306
:CALCulate:RHO:LIMit:MAC:INACTive[:UPPer]<float>307
:CALCulate:RHO:LIMit:MAC:INACTive[:UPPer]?307
:CALCulate:RHO:LIMit:PEAK[:BTS] <float>307
:CALCulate:RHO:LIMit:PEAK[:BTS]?307
:CALCulate:RHO:LIMit:PHASe <float>307
:CALCulate:RHO:LIMit:PHASe?307
:CALCulate:RHO:LIMit:POFFset <float>308
:CALCulate:RHO:LIMit:POFFset?308
:CALCulate:RHO:LIMit:RHO[:BTS] <float>308
:CALCulate:RHO:LIMit:RHO[:BTS]?308
:CALCulate:RHO:LIMit:RMS[:BTS] <float>308
:CALCulate:RHO:LIMit:RMS[:BTS]?308
:CALCulate:RHO:LIMit:TIMing <float>308

List of Commands

:CALCulate:RHO:LIMit:TIMing?	308
:CALCulate:RHO:TYPE ALL DATA MAC PILot PREamble	309
:CALCulate:RHO:TYPE:DATA OPSK QAM QPSK	309
:CALCulate:RHO:TYPE:DATA?	309
:CALCulate:RHO:TYPE?	309
:CALCulate:TCDPower:ASET:THReshold <numeric>	277
:CALCulate:TCDPower:ASET:THReshold:AUTO OFF ON 0 1	277
:CALCulate:TCDPower:ASET:THReshold:AUTO?	277
:CALCulate:TCDPower:ASET:THReshold?	277
:CALCulate:TCDPower:AXIS IPH QPH	277
:CALCulate:TCDPower:AXIS?	277
:CALCulate:TCDPower:SWEEp:OFFSet <integer>	278
:CALCulate:TCDPower:SWEEp:OFFSet?	278
:CALCulate:TCDPower:SWEEp:TIME <integer>	278
:CALCulate:TCDPower:SWEEp:TIME?	278
:CALCulate:TCDPower:TYPE ABSolute RELative	278
:CALCulate:TCDPower:TYPE?	278
:CALCulate:TCDPower:WCODe:LENGth <integer>	279
:CALCulate:TCDPower:WCODe:LENGth?	279
:CALCulate:TCDPower:WCODe:ORDeR BREVerse (HADamard HADMrd)	279
:CALCulate:TCDPower:WCODe:ORDeR?	279
:CALCulate:TCDPower:WCODe[:NUMBer] <integer>	279
:CALCulate:TCDPower:WCODe[:NUMBer]?	279
:CALCulate:TRHO:ASET:THReshold <numeric>	311
:CALCulate:TRHO:ASET:THReshold:AUTO OFF ON 0 1	311
:CALCulate:TRHO:ASET:THReshold:AUTO?	311
:CALCulate:TRHO:ASET:THReshold?	311
:CALCulate:TRHO:IQOFFset:INCLude OFF ON 0 1	311
:CALCulate:TRHO:IQOFFset:INCLude?	311
:CALCulate:TRHO:LIMit:ACDPower <float>	312
:CALCulate:TRHO:LIMit:ACK:GAIN <float>	312

List of Commands

:CALCulate:TRHO:LIMit:CDErRor <float>	.312
:CALCulate:TRHO:LIMit:CDErRor?	.312
:CALCulate:TRHO:LIMit:DATA:GAIN <float>	.313
:CALCulate:TRHO:LIMit:DRC:GAIN <float>	.313
:CALCulate:TRHO:LIMit:FERRor <float>	.313
:CALCulate:TRHO:LIMit:FERRor?	.313
:CALCulate:TRHO:LIMit:ICDPower <float>	.313
:CALCulate:TRHO:LIMit:ICDPower?	.313
:CALCulate:TRHO:LIMit:PEAK <float>	.314
:CALCulate:TRHO:LIMit:PEAK?	.314
:CALCulate:TRHO:LIMit:POFFset <float>	.314
:CALCulate:TRHO:LIMit:POFFset?	.314
:CALCulate:TRHO:LIMit:RHO <float>	.314
:CALCulate:TRHO:LIMit:RHO?	.314
:CALCulate:TRHO:LIMit:RMS <float>	.315
:CALCulate:TRHO:LIMit:RMS?	.315
:CALCulate:TRHO:LIMit:RRI <float>	.315
:CALCulate:TRHO:LIMit:RRI?	.315
:CALCulate:<measurement>:MARKer:AOFF	.293
:CALCulate:<measurement>:MARKer[1] 2 3 4:FUNCTion:RESult?	.293
:CALCulate:<measurement>:MARKer[1] 2 3 4:MAXimum	.293
:CALCulate:<measurement>:MARKer[1] 2 3 4:MINimum	.294
:CALCulate:<measurement>:MARKer[1] 2 3 4:MODE POSition DELTa	.294
:CALCulate:<measurement>:MARKer[1] 2 3 4:MODE POSition DELTa RMSDeegree RMSRadi-an RFM RMSJitter OFF	.294
:CALCulate:<measurement>:MARKer[1] 2 3 4:MODE?	.294
:CALCulate:<measurement>:MARKer[1] 2 3 4:TRACe <trace_name>	.295
:CALCulate:<measurement>:MARKer[1] 2 3 4:TRACe?	.295
:CALCulate:<measurement>:MARKer[1] 2 3 4:X <param>	.299
:CALCulate:<measurement>:MARKer[1] 2 3 4:X:POSition <integer>	.300
:CALCulate:<measurement>:MARKer[1] 2 3 4:X:POSition?	.300

List of Commands

:CALCulate:<measurement>:MARKer[1] 2 3 4:X?	299
:CALCulate:<measurement>:MARKer[1] 2 3 4:Y?	300
:CALCulate:<measurement>:MARKer[1] 2 3 4[:STATe] OFF ON 0 1	295
:CALCulate:<measurement>:MARKer[1] 2 3 4[:STATe]?	295
:CONFigure:CDPower	343
:CONFigure:CHPower	359
:CONFigure:EVMQpsk	361
:CONFigure:IM	364
:CONFigure:OBW	367
:CONFigure:PStatistic	369
:CONFigure:PVTime	371
:CONFigure:RHO	376
:CONFigure:SEMask	392
:CONFigure:SPECTrum	398
:CONFigure:TCDPower	401
:CONFigure:TRHO	405
:CONFigure:WAVEform	408
:CONFigure:<measurement>	316
:CONFigure?	316
:DISPlay:CDPower:VIEW PGRaph IQPGraph	317
:DISPlay:CDPower:VIEW?	317
:DISPlay:FORMat:TILE	317
:DISPlay:FORMat:ZOOM	318
:DISPlay:PVTime:BURSt:STHReshold OFF ON 0 1	318
:DISPlay:PVTime:BURSt:STHReshold?	318
:DISPlay:PVTime:LIMit:MASK OFF ON 0 1	318
:DISPlay:PVTime:LIMit:MASK?	318
:DISPlay:PVTime:VIEW ALL BOTH A B C D E	319
:DISPlay:PVTime:VIEW?	319
:DISPlay:RHO:VIEW ERRor POLar	319
:DISPlay:RHO:VIEW ERRor POLar PGRaph TABLE	319

List of Commands

:DISPlay:RHO:VIEW ERRor POLar QUAD TABLE TPHase319
:DISPlay:RHO:VIEW ERRor POLar TABLE319
:DISPlay:RHO:VIEW?319
:DISPlay:SPECTrum[n]:WINDow[m]:TRACe:Y[:SCALe]:PDIVision <power>320
:DISPlay:SPECTrum[n]:WINDow[m]:TRACe:Y[:SCALe]:PDIVision?320
:DISPlay:SPECTrum[n]:WINDow[m]:TRACe:Y[:SCALe]:RLEVel <power>321
:DISPlay:SPECTrum[n]:WINDow[m]:TRACe:Y[:SCALe]:RLEVel?321
:DISPlay:TCDPower:VIEW PGRaph QUAD SEVM DBITs322
:DISPlay:TCDPower:VIEW?322
:DISPlay:TRACe[n][:STATe] OFF ON 0 1323
:DISPlay:TRACe[n][:STATe]?323
:DISPlay:WAVeform[n]:WINDow[m]:TRACe:Y[:SCALe]:PDIVision <power>328
:DISPlay:WAVeform[n]:WINDow[m]:TRACe:Y[:SCALe]:PDIVision?328
:DISPlay:WAVeform[n]:WINDow[m]:TRACe:Y[:SCALe]:RLEVel <power>329
:DISPlay:WAVeform[n]:WINDow[m]:TRACe:Y[:SCALe]:RLEVel?329
:FETCh:CDPower[n]?343
:FETCh:CHPower[n]?359
:FETCh:EVMQpsk[n]?361
:FETCh:IM[n]?364
:FETCh:OBW[n]?367
:FETCh:PSTatistic[n]?369
:FETCh:PVTime[n]?371
:FETCh:RHO[n]?376
:FETCh:SEMask[n]?392
:FETCh:SPECTrum[n]?398
:FETCh:TCDPower[n]?401
:FETCh:TRHO[n]?405
:FETCh:WAVeform[n]?408
:FETCh:<measurement>[n]?331
:FORMat:BORDER NORMal SWAPped332
:FORMat:BORDER?332

List of Commands

:FORMat[:DATA] ASCii REAL,32 REAL,64	332
:FORMat[:DATA]?	332
:FORMat[:TRACe][:DATA] ASCii INTeger,16 INTeger,32 REAL,32 REAL,64 UINTEger,16	332
:FORMat[:TRACe][:DATA] ASCii REAL[,32]	332
:FORMat[:TRACe][:DATA]?	332
:FORMat[:TRACe][:DATA]?	332
:INITiate:CDPower	343
:INITiate:CHPower	359
:INITiate:CONTinuous OFF ON 0 1	334
:INITiate:CONTinuous?	334
:INITiate:EVMQpsk	361
:INITiate:IM	364
:INITiate:OBW	367
:INITiate:PSStatistic	369
:INITiate:PVTime	371
:INITiate:REStart	335
:INITiate:RHO	376
:INITiate:SEMAsk	392
:INITiate:SPECtrum	398
:INITiate:TCDPower	401
:INITiate:TRHO	405
:INITiate:WAVEform	408
:INITiate:<measurement>	334
:INITiate[:IMMEdiate]	335
:INSTrument:CATalog?	336
:INSTrument:CATalog[:FULL]?	336
:INSTrument:NSElect <integer>	336
:INSTrument:NSElect?	336
:INSTrument[:SElect] BASIC SERVICE CD- MA CDMA2K GSM EDGEgsm IDEN NADC PDC WCDMA CDMA1XEV	337
:INSTrument[:SElect] SA PNOISE BASIC CDMA CDMA2K EDGEgsm NADC PDC WCD-	

List of Commands

MA CDMA1XEV NFIGURE337
:INSTrument[:SElect]?	.337
:MEASure:CDPower[n]?	.343
:MEASure:CHPower[n]?	.359
:MEASure:EVMQpsk[n]?	.361
:MEASure:IM[n]?	.364
:MEASure:OBW[n]?	.367
:MEASure:PStatic[n]?	.369
:MEASure:PVTime[n]?	.371
:MEASure:RHO[n]?	.376
:MEASure:SEMask[n]?	.392
:MEASure:SPECTrum[n]?	.398
:MEASure:TCDPower[n]?	.401
:MEASure:TRHO[n]?	.405
:MEASure:WAVEform[n]?	.408
:READ:CDPower[n]?	.343
:READ:CHPower[n]?	.359
:READ:EVMQpsk[n]?	.361
:READ:IM[n]?	.364
:READ:OBW[n]?	.367
:READ:PStatic[n]?	.369
:READ:PVTime[n]?	.371
:READ:RHO[n]?	.376
:READ:SEMask[n]?	.392
:READ:SPECTrum[n]?	.398
:READ:TCDPower[n]?	.401
:READ:TRHO[n]?	.405
:READ:WAVEform[n]?	.408
:READ:<measurement>[n]?	.410
:TRIGger[:SEquence]:AUTO:STATe OFF ON 0 1536
:TRIGger[:SEquence]:AUTO:STATe?	.536

List of Commands

:TRIGger[:SEQuence]:AUTO[:TIME] <time>	536
:TRIGger[:SEQuence]:AUTO[:TIME]?	536
:TRIGger[:SEQuence]:EXTErnal[1] 2:DELAy <time>	537
:TRIGger[:SEQuence]:EXTErnal[1] 2:DELAy?	537
:TRIGger[:SEQuence]:EXTErnal[1] 2:LEVel <voltage>	537
:TRIGger[:SEQuence]:EXTErnal[1] 2:LEVel?	537
:TRIGger[:SEQuence]:EXTErnal[1] 2:SLOPe NEGative POSitive	537
:TRIGger[:SEQuence]:EXTErnal[1] 2:SLOPe?	538
:TRIGger[:SEQuence]:FRAME:ADJust <time>	538
:TRIGger[:SEQuence]:FRAME:PERiod <time>	538
:TRIGger[:SEQuence]:FRAME:PERiod?	538
:TRIGger[:SEQuence]:FRAME:SYNC EXTFront EXTReAr OFF	539
:TRIGger[:SEQuence]:FRAME:SYNC:OFFSet <time>	539
:TRIGger[:SEQuence]:FRAME:SYNC:OFFSet?	539
:TRIGger[:SEQuence]:FRAME:SYNC?	539
:TRIGger[:SEQuence]:HOLDoff <time>	540
:TRIGger[:SEQuence]:HOLDoff?	540
:TRIGger[:SEQuence]:IF:DELAy <time>	540
:TRIGger[:SEQuence]:IF:DELAy?	540
:TRIGger[:SEQuence]:IF:LEVel <ampl>	540
:TRIGger[:SEQuence]:IF:LEVel?	540
:TRIGger[:SEQuence]:IF:SLOPe NEGative POSitive	541
:TRIGger[:SEQuence]:IF:SLOPe?	541
:TRIGger[:SEQuence]:RFBurst:DELAy <time>	541
:TRIGger[:SEQuence]:RFBurst:DELAy?	541
:TRIGger[:SEQuence]:RFBurst:LEVel <rel_power>	541
:TRIGger[:SEQuence]:RFBurst:LEVel?	541
:TRIGger[:SEQuence]:RFBurst:SLOPe NEGative POSitive	542
:TRIGger[:SEQuence]:RFBurst:SLOPe?	542
[:SENSe]:CDPower:ACODE AUTO PREDeFined	411
[:SENSe]:CDPower:ACODE?	411

List of Commands

[:SENSe]:CDPower:ADC:RANGe AUTO APEak APLOCK M6 P0 P6 P12 P18 P24	411
[:SENSe]:CDPower:ADC:RANGe AUTO APEak APLOCK NONE P0 P6 P12 P18	411
[:SENSe]:CDPower:ADC:RANGe?	411
[:SENSe]:CDPower:CAPTure:TIME <numeric>	413
[:SENSe]:CDPower:CAPTure:TIME?	413
[:SENSe]:CDPower:CRATe <freq>	413
[:SENSe]:CDPower:CRATe?	413
[:SENSe]:CDPower:PILOt:COMPensation[:STATe] OFF ON 0 1	414
[:SENSe]:CDPower:PILOt:COMPensation[:STATe]?	414
[:SENSe]:CDPower:PNOFset <integer>	414
[:SENSe]:CDPower:PNOFset?	414
[:SENSe]:CDPower:PREamble:LENGth <integer>	415
[:SENSe]:CDPower:PREamble:LENGth:AUTO OFF ON 0 1	415
[:SENSe]:CDPower:PREamble:LENGth:AUTO?	415
[:SENSe]:CDPower:PREamble:LENGth?	415
[:SENSe]:CDPower:SPECTrum INVert NORMal	415
[:SENSe]:CDPower:SPECTrum?	415
[:SENSe]:CDPower:TRIGger:SOURce EXTernal[1] External2 FRAME IF IMMEDIATE RFBurst	416
[:SENSe]:CDPower:TRIGger:SOURce?	416
[:SENSe]:CHPower:AVERage:TCONtrol EXPOntial REPEAT	417
[:SENSe]:CHPower:AVERage:TCONtrol?	417
[:SENSe]:CHPower:AVERage[:STATe] OFF ON 0 1	417
[:SENSe]:CHPower:AVERage[:STATe]?	417
[:SENSe]:CHPower:FREQuency:SPAN <freq>	418
[:SENSe]:CHPower:FREQuency:SPAN?	418
[:SENSe]:CHPower:POINts <integer>	418
[:SENSe]:CHPower:POINts:AUTO OFF ON 0 1	418
[:SENSe]:CHPower:POINts:AUTO?	418
[:SENSe]:CHPower:POINts?	418
[:SENSe]:CHPower:SWEep:TIME <time>	419

List of Commands

[[:SENSe]:CHPower:SWEep:TIME:AUTO OFF ON 0 1.....	419
[[:SENSe]:CHPower:SWEep:TIME:AUTO?	419
[[:SENSe]:CHPower:SWEep:TIME?	419
[[:SENSe]:CHPower:TRIGger:SOURce EXTernal[1] EXTernal2 IMMEDIATE	420
[[:SENSe]:CHPower:TRIGger:SOURce?	420
[[:SENSe]:CORRection:BTS[:RF]:LOSS <rel_power>	421
[[:SENSe]:CORRection:BTS[:RF]:LOSS?	421
[[:SENSe]:CORRection:MS[:RF]:LOSS <rel_power>	421
[[:SENSe]:CORRection:MS[:RF]:LOSS?	421
[[:SENSe]:EVMQpsk:ADC:RANGe AUTO APEak APLock M6 P0 P6 P12 P18 P24	422
[[:SENSe]:EVMQpsk:ADC:RANGe AUTO APEak APLock NONE P0 P6 P12 P18.....	422
[[:SENSe]:EVMQpsk:ADC:RANGe?	422
[[:SENSe]:EVMQpsk:AVERage:COUNt <integer>	423
[[:SENSe]:EVMQpsk:AVERage:COUNt?	423
[[:SENSe]:EVMQpsk:AVERage:TCONtrol EXPonential REPeat	424
[[:SENSe]:EVMQpsk:AVERage:TCONtrol?	424
[[:SENSe]:EVMQpsk:AVERage[:STATe] OFF ON 0 1	423
[[:SENSe]:EVMQpsk:AVERage[:STATe]?	423
[[:SENSe]:EVMQpsk:CRATe <freq>	424
[[:SENSe]:EVMQpsk:CRATe?	424
[[:SENSe]:EVMQpsk:RFCarrier MULTiple SINGle	425
[[:SENSe]:EVMQpsk:RFCarrier?	425
[[:SENSe]:EVMQpsk:SWEep:POINts <integer>	425
[[:SENSe]:EVMQpsk:SWEep:POINts:OFFSet <number>.....	425
[[:SENSe]:EVMQpsk:SWEep:POINts:OFFSet?	425
[[:SENSe]:EVMQpsk:SWEep:POINts?	425
[[:SENSe]:EVMQpsk:TRIGger:SOURce EXTernal[1] EXTernal2 FRAMe IF IMMEDIATE RFBurst 426	
[[:SENSe]:EVMQpsk:TRIGger:SOURce?	426
[[:SENSe]:FEED RF AREFERENCE IFALign.....	427
[[:SENSe]:FEED RF IQ IONLy QONLy AREFERENCE IFALign.....	427

List of Commands

[:SENSe]:FEED?	427
[:SENSe]:IM:AVERAge:COUNT <number>	428
[:SENSe]:IM:AVERAge:COUNT?	428
[:SENSe]:IM:AVERAge:TCONtrol EXPonential REPeat	428
[:SENSe]:IM:AVERAge:TCONtrol?	428
[:SENSe]:IM:AVERAge[:STATe] OFF ON 0 1	428
[:SENSe]:IM:AVERAge[:STATe]?	428
[:SENSe]:IM:BANDwidth BWIDth:INTegration <freq>	429
[:SENSe]:IM:BANDwidth BWIDth:INTegration?	429
[:SENSe]:IM:BANDwidth BWIDth[:RESolution] <freq>	429
[:SENSe]:IM:BANDwidth BWIDth[:RESolution]:AUTO OFF ON 0 1	430
[:SENSe]:IM:BANDwidth BWIDth[:RESolution]:AUTO?	430
[:SENSe]:IM:BANDwidth BWIDth[:RESolution]?	429
[:SENSe]:IM:FREQuency:AUTO OFF ON 0 1	430
[:SENSe]:IM:FREQuency:AUTO?	430
[:SENSe]:IM:FREQuency:SPAN <freq>	432
[:SENSe]:IM:FREQuency:SPAN?	432
[:SENSe]:IM:FREQuency[:BASE]:DELTA <freq>	430
[:SENSe]:IM:FREQuency[:BASE]:DELTA?	430
[:SENSe]:IM:FREQuency[:BASE]:LOWer <freq>	431
[:SENSe]:IM:FREQuency[:BASE]:LOWer?	431
[:SENSe]:IM:FREQuency[:BASE]:UPPer <freq>	431
[:SENSe]:IM:FREQuency[:BASE]:UPPer?	431
[:SENSe]:IM:MODE AUTO TWOTone TXIM	432
[:SENSe]:IM:MODE?	432
[:SENSe]:IM:REFerence AUTO AVERAge LOWer UPPer	432
[:SENSe]:IM:REFerence?	432
[:SENSe]:OBW:AVERAge:COUNT <integer>	434
[:SENSe]:OBW:AVERAge:COUNT?	434
[:SENSe]:OBW:AVERAge:TCONtrol EXPonential REPeat	435
[:SENSe]:OBW:AVERAge:TCONtrol?	435

List of Commands

[[:SENSe]:OBW:AVERAge[:STATe] OFF ON 0 1	434
[[:SENSe]:OBW:AVERAge[:STATe]?	434
[[:SENSe]:OBW:BANDwidth BWIDth[:RESolution] <freq>	435
[[:SENSe]:OBW:BANDwidth BWIDth[:RESolution]?	435
[[:SENSe]:OBW:FFT:WINDow[:TYPE] BH4Tap BLACKman FLATtop GAUSSian HAMMING HANNing KB70 KB90 KB110 UNIFORM	435
[[:SENSe]:OBW:FFT:WINDow[:TYPE]?	436
[[:SENSe]:OBW:FREQuency:SPAN <freq>	436
[[:SENSe]:OBW:FREQuency:SPAN?	436
[[:SENSe]:OBW:TRIGger:SOURce EXTERNAL[1] EXTERNAL2 FRAME IF IMMEDIATE LINE RFBurst	437
[[:SENSe]:OBW:TRIGger:SOURce EXTERNAL[1] EXTERNAL2 IF IMMEDIATE RFBurst	436
[[:SENSe]:OBW:TRIGger:SOURce EXTERNAL[1] EXTERNAL2 IF IMMEDIATE RFBurst	437
[[:SENSe]:OBW:TRIGger:SOURce?	437
[[:SENSe]:OBW:TRIGger:SOURce?	437
[[:SENSe]:OBW:TRIGger:SOURce?	437
[[:SENSe]:POWER[:RF]:ATTenuation <rel_power>	438
[[:SENSe]:POWER[:RF]:ATTenuation?	438
[[:SENSe]:POWER[:RF]:GAIN:ATTenuation <rel_power>	438
[[:SENSe]:POWER[:RF]:GAIN:ATTenuation?	438
[[:SENSe]:POWER[:RF]:GAIN[:STATe] OFF ON 0 1	438
[[:SENSe]:POWER[:RF]:GAIN[:STATe]?	438
[[:SENSe]:POWER[:RF]:RANGe:AUTO OFF ON 0 1	439
[[:SENSe]:POWER[:RF]:RANGe:AUTO?	439
[[:SENSe]:POWER[:RF]:RANGe[:UPPer] <power>	439
[[:SENSe]:POWER[:RF]:RANGe[:UPPer]?	440
[[:SENSe]:PSTATistic:BANDwidth BWIDth <freq>	441
[[:SENSe]:PSTATistic:BANDwidth BWIDth?	441
[[:SENSe]:PSTATistic:COUNts <integer>	441
[[:SENSe]:PSTATistic:COUNts?	441
[[:SENSe]:PSTATistic:SWEep:TIME <time>	441

List of Commands

[[:SENSE]:PSTatistic:SWEep:TIME?	442
[[:SENSE]:PSTatistic:TRIGger:SOURce EXTernal[1] EXTernal2 FRAME IF IMMEDIATE RFBurst. 442	
[[:SENSE]:PSTatistic:TRIGger:SOURce?	442
[[:SENSE]:PVTime:AVERAge:COUNT <integer>	443
[[:SENSE]:PVTime:AVERAge:COUNT?	443
[[:SENSE]:PVTime:AVERAge:TCONtrol EXPonential REPeat	444
[[:SENSE]:PVTime:AVERAge:TCONtrol?	444
[[:SENSE]:PVTime:AVERAge:TYPE LOG MAXimum MINimum MXMinimum RMS	444
[[:SENSE]:PVTime:AVERAge:TYPE LOG MAXimum MINimum MXMinimum RMS SCALar .444	
[[:SENSE]:PVTime:AVERAge:TYPE RMS MAXimum MINimum	444
[[:SENSE]:PVTime:AVERAge:TYPE?	444
[[:SENSE]:PVTime:AVERAge[:STATe] OFF ON 0 1	443
[[:SENSE]:PVTime:AVERAge[:STATe]?	443
[[:SENSE]:PVTime:BANDwidth BWIDth[:RESolution] <freq>	445
[[:SENSE]:PVTime:BANDwidth BWIDth[:RESolution]:TYPE FLATtop GAUSSian	445
[[:SENSE]:PVTime:BANDwidth BWIDth[:RESolution]:TYPE?	446
[[:SENSE]:PVTime:BANDwidth BWIDth[:RESolution]?	445
[[:SENSE]:PVTime:BURSt:SLOPe <number>	446
[[:SENSE]:PVTime:BURSt:SLOPe:INTegration:TIME <number>	447
[[:SENSE]:PVTime:BURSt:SLOPe:INTegration:TIME?	447
[[:SENSE]:PVTime:BURSt:SLOPe?	447
[[:SENSE]:PVTime:BURSt:STHReshold <rel_power>	446
[[:SENSE]:PVTime:BURSt:STHReshold?	446
[[:SENSE]:PVTime:LIMit:MASK OFF ON 0 1	447
[[:SENSE]:PVTime:LIMit:MASK?	447
[[:SENSE]:PVTime:MASK:ASLot:LOWer:RELative <rel_power>	448
[[:SENSE]:PVTime:MASK:ASLot:LOWer:RELative?	448
[[:SENSE]:PVTime:MASK:ASLot:LOWer:TEST RELative NONE	448
[[:SENSE]:PVTime:MASK:ASLot:LOWer:TEST?	448
[[:SENSE]:PVTime:MASK:ASLot:SWEep:TIME <time>	448

List of Commands

[:SENSe]:PVTime:MASK:ASLot:SWEp:TIME?	449
[:SENSe]:PVTime:MASK:ASLot:UPPer:RELative <rel_power>	449
[:SENSe]:PVTime:MASK:ASLot:UPPer:RELative?	449
[:SENSe]:PVTime:MASK:ASLot:UPPer:TEST RELative NONE	449
[:SENSe]:PVTime:MASK:ASLot:UPPer:TEST?	449
[:SENSe]:PVTime:MASK:LIST:LOWer:RELative <rel_power>, <rel_power>, <rel_power>, <rel_power>, <rel_power>	450
[:SENSe]:PVTime:MASK:LIST:LOWer:RELative?	450
[:SENSe]:PVTime:MASK:LIST:LOWer:TEST RELative NONE, ,RELative NONE, RELative NONE, RELative NONE, RELative NONE	450
[:SENSe]:PVTime:MASK:LIST:LOWer:TEST?	451
[:SENSe]:PVTime:MASK:LIST:SWEp:TIME <time>, <time>, <time>, <time>, <time>	451
[:SENSe]:PVTime:MASK:LIST:SWEp:TIME?	451
[:SENSe]:PVTime:MASK:LIST:TIME <time>, <time>, <time>, <time>, <time>	452
[:SENSe]:PVTime:MASK:LIST:TIME?	452
[:SENSe]:PVTime:MASK:LIST:UPPer:RELative <rel_power>, <rel_power>, <rel_power>, <rel_power>, <rel_power>	452
[:SENSe]:PVTime:MASK:LIST:UPPer:RELative?	452
[:SENSe]:PVTime:MASK:LIST:UPPer:TEST RELative NONE, RELative NONE, RELative NONE, RELative NONE, RELative NONE	454
[:SENSe]:PVTime:MASK:LIST:UPPer:TEST?	454
[:SENSe]:PVTime:MASK:PREFerence A B C D E	451
[:SENSe]:PVTime:MASK:PREFerence?	451
[:SENSe]:PVTime:MASK:REFerence TRIGger RISE CENTer	454
[:SENSe]:PVTime:MASK:REFerence?	454
[:SENSe]:PVTime:MASK:REFerence[:OFFSet]:TIME <time>	455
[:SENSe]:PVTime:MASK:REFerence[:OFFSet]:TIME?	455
[:SENSe]:PVTime:SLOT[:TYPE] IDLE ACTive	455
[:SENSe]:PVTime:SLOT[:TYPE]?	455
[:SENSe]:PVTime:TRIGger:SOURce EXTernal[1] EXTernal2 FRAMe LINE IF IMMEDIATE RFBurst	456
[:SENSe]:PVTime:TRIGger:SOURce?	456
[:SENSe]:RADio:CARRier:NUMBer SINGle MULTiple	457

List of Commands

[[:SENSe]:RADio:CARRier:NUMBer?	457
[[:SENSe]:RADio:DEVice BTS MS	457
[[:SENSe]:RADio:DEVice?	457
[[:SENSe]:RHO:ACODE AUTO PREDefined	458
[[:SENSe]:RHO:ACODE?	458
[[:SENSe]:RHO:ADC:RANGe AUTO APEak APLock NONE M6 P0 P6 P12 P18 P24.	458
[[:SENSe]:RHO:ADC:RANGe?	458
[[:SENSe]:RHO:AVERage:COUNT <integer>	459
[[:SENSe]:RHO:AVERage:COUNT?	459
[[:SENSe]:RHO:AVERage:TCONtrol EXPonential REPeat.	460
[[:SENSe]:RHO:AVERage:TCONtrol?	460
[[:SENSe]:RHO:AVERage[:STATe] OFF ON 0 1	459
[[:SENSe]:RHO:AVERage[:STATe]?	460
[[:SENSe]:RHO:CRATe <freq>	460
[[:SENSe]:RHO:CRATe?	460
[[:SENSe]:RHO:MCEStimator OFF ON 0 1.	461
[[:SENSe]:RHO:MCEStimator?	461
[[:SENSe]:RHO:PNOffset <integer>	461
[[:SENSe]:RHO:PNOffset?	461
[[:SENSe]:RHO:PREamble:LENGth <integer>	461
[[:SENSe]:RHO:PREamble:LENGth:AUTO OFF ON 0 1	462
[[:SENSe]:RHO:PREamble:LENGth:AUTO?	462
[[:SENSe]:RHO:PREamble:LENGth?	461
[[:SENSe]:RHO:PREamble:STATe OFF ON 0 1	462
[[:SENSe]:RHO:PREamble:STATe?	462
[[:SENSe]:RHO:SPECTrum INVert NORMAl	462
[[:SENSe]:RHO:SPECTrum?	462
[[:SENSe]:RHO:TRIGger:SOURce EXTernal[1] External2 FRAMe IF IMMEDIATE RFBurst. .	463
[[:SENSe]:RHO:TRIGger:SOURce?	463
[[:SENSe]:SEMAsk:AVERage:COUNT <integer>	464
[[:SENSe]:SEMAsk:AVERage:COUNT?	464

List of Commands

[:SENSe]:SEMAsk:AVERAge:TCONtrol EXPonential REPeat	464
[:SENSe]:SEMAsk:AVERAge:TCONtrol?	464
[:SENSe]:SEMAsk:AVERAge[:STATe] OFF ON 0 1	464
[:SENSe]:SEMAsk:AVERAge[:STATe]?	464
[:SENSe]:SEMAsk:BANDwidth[n] BWIDth[n]:INTegration <freq>	465
[:SENSe]:SEMAsk:BANDwidth[n] BWIDth[n]:INTegration?	465
[:SENSe]:SEMAsk:BANDwidth[n] BWIDth[n]:RESolution <freq>	466
[:SENSe]:SEMAsk:BANDwidth[n] BWIDth[n]:RESolution:AUTO OFF ON 0 1	466
[:SENSe]:SEMAsk:BANDwidth[n] BWIDth[n]:RESolution:AUTO?	466
[:SENSe]:SEMAsk:BANDwidth[n] BWIDth[n]:RESolution?	466
[:SENSe]:SEMAsk:BANDwidth BWIDth:INTegration[m] <freq>	465
[:SENSe]:SEMAsk:BANDwidth BWIDth:INTegration[m]?	465
[:SENSe]:SEMAsk:BANDwidth BWIDth:RESolution[m] <freq>	466
[:SENSe]:SEMAsk:BANDwidth BWIDth:RESolution[m]:AUTO OFF ON 0 1	466
[:SENSe]:SEMAsk:BANDwidth BWIDth:RESolution[m]:AUTO?	466
[:SENSe]:SEMAsk:BANDwidth BWIDth:RESolution[m]?	466
[:SENSe]:SEMAsk:DETEctor[:FUNction] AAverage POSitive	467
[:SENSe]:SEMAsk:DETEctor[:FUNction]?	467
[:SENSe]:SEMAsk:FREQuency:STEP[m] <freq>	468
[:SENSe]:SEMAsk:FREQuency:STEP[m]:AUTO OFF ON 0 1	468
[:SENSe]:SEMAsk:FREQuency:STEP[m]:AUTO?	469
[:SENSe]:SEMAsk:FREQuency:STEP[m]?	468
[:SENSe]:SEMAsk:FREQuency[n]:SPAN[m] <freq>	467
[:SENSe]:SEMAsk:FREQuency[n]:SPAN[m]?	467
[:SENSe]:SEMAsk:FREQuency[n]:STEP <freq>	468
[:SENSe]:SEMAsk:FREQuency[n]:STEP:AUTO OFF ON 0 1	468
[:SENSe]:SEMAsk:FREQuency[n]:STEP:AUTO?	468
[:SENSe]:SEMAsk:FREQuency[n]:STEP?	468
[:SENSe]:SEMAsk:OFFSet:LIST[m]:BANDwidth BWIDth <res_bw>,<res_bw>,<res_bw>,<res_bw>,<res_bw>	469
[:SENSe]:SEMAsk:OFFSet:LIST[m]:BANDwidth BWIDth:AUTO OFF ON 0 1,OFF ON 0 1,OFF ON 0 1,OFF ON 0 1,OFF ON 0 1	470

List of Commands

[:SENSe]:SEMAsk:OFFSet:LIST[m]:BANDwidth BWIDth:AUTO?	470
[:SENSe]:SEMAsk:OFFSet:LIST[m]:BANDwidth BWIDth:IMULti <integer>,<integer>,<integer>,<integer>,<integer>	471
[:SENSe]:SEMAsk:OFFSet:LIST[m]:BANDwidth BWIDth:IMULti?	471
[:SENSe]:SEMAsk:OFFSet:LIST[m]:BANDwidth BWIDth?	469
[:SENSe]:SEMAsk:OFFSet:LIST[m]:FREQuency:STARt <f_offset>,<f_offset>,<f_offset>,<f_offset>,<f_offset>	472
[:SENSe]:SEMAsk:OFFSet:LIST[m]:FREQuency:STARt?	472
[:SENSe]:SEMAsk:OFFSet:LIST[m]:FREQuency:STEP <f_offset>,<f_offset>,<f_offset>,<f_offset>,<f_offset>	473
[:SENSe]:SEMAsk:OFFSet:LIST[m]:FREQuency:STEP:AUTO OFF ON 0 1,OFF ON 0 1,OFF ON 0 1,OFF ON 0 1,OFF ON 0 1	474
[:SENSe]:SEMAsk:OFFSet:LIST[m]:FREQuency:STEP:AUTO?	474
[:SENSe]:SEMAsk:OFFSet:LIST[m]:FREQuency:STEP?	473
[:SENSe]:SEMAsk:OFFSet:LIST[m]:FREQuency:STOP <f_offset>,<f_offset>,<f_offset>,<f_offset>,<f_offset>	474
[:SENSe]:SEMAsk:OFFSet:LIST[m]:FREQuency:STOP?	475
[:SENSe]:SEMAsk:OFFSet:LIST[m]:RATTenuation <rel_power>,<rel_power>,<rel_power>,<rel_power>,<rel_power>	475
[:SENSe]:SEMAsk:OFFSet:LIST[m]:RATTenuation?	475
[:SENSe]:SEMAsk:OFFSet:LIST[m]:SIDE BOTH NEGative POSitive, BOTH NEGative POSitive,BOTH NEGative POSitive, BOTH NEGative POSi- tive,BOTH NEGative POSitive	477
[:SENSe]:SEMAsk:OFFSet:LIST[m]:SIDE?	477
[:SENSe]:SEMAsk:OFFSet:LIST[m]:STARt:ABSolute <abs_power>,<abs_power>,<abs_power>,<abs_power>,<abs_power>	477
[:SENSe]:SEMAsk:OFFSet:LIST[M]:STARt:ABSolute?	477
[:SENSe]:SEMAsk:OFFSet:LIST[m]:STARt:RCARrier <rel_power>,<rel_power>,<rel_power>,<rel_power>,<rel_power>	478
[:SENSe]:SEMAsk:OFFSet:LIST[m]:STARt:RCARrier?	479
[:SENSe]:SEMAsk:OFFSet:LIST[m]:STATe OFF ON 0 1,OFF ON 0 1,OFF ON 0 1,OFF ON 0 1,OFF ON 0 1	480
[:SENSe]:SEMAsk:OFFSet:LIST[m]:STATe?	480
[:SENSe]:SEMAsk:OFFSet:LIST[m]:STOP:ABSolute <abs_power>,<abs_power>,<abs_power>,<abs_power>,<abs_power>	480

List of Commands

[:SENSe]:SEMAsk:OFFSet:LIST[m]:STOP:ABSolute:COUPle OFF ON 0 1,OFF ON 0 1,OFF ON 0 1,OFF ON 0 1,OFF ON 0 1	482
[:SENSe]:SEMAsk:OFFSet:LIST[m]:STOP:ABSolute:COUPle?	482
[:SENSe]:SEMAsk:OFFSet:LIST[m]:STOP:ABSolute?	480
[:SENSe]:SEMAsk:OFFSet:LIST[m]:STOP:RCARrier <rel_power>,<rel_power>,<rel_power>,<rel_power>,<rel_power>	482
[:SENSe]:SEMAsk:OFFSet:LIST[m]:STOP:RCARrier:COUPle OFF ON 0 1,OFF ON 0 1,OFF ON 0 1,OFF ON 0 1,OFF ON 0 1	484
[:SENSe]:SEMAsk:OFFSet:LIST[m]:STOP:RCARrier:COUPle?	484
[:SENSe]:SEMAsk:OFFSet:LIST[m]:STOP:RCARrier?	482
[:SENSe]:SEMAsk:OFFSet:LIST[m]:TEST ABSolute AND OR RELative,ABSolute AND OR RELative, ABSolute AND OR RELative,ABSolute AND OR RELative, ABSolute AND OR RELative	484
[:SENSe]:SEMAsk:OFFSet:LIST[m]:TEST?	485
[:SENSe]:SEMAsk:OFFSet[n]:LIST:BANDwidth BWIDth <res_bw>,<res_bw>,<res_bw>,<res_bw>,<res_bw>	469
[:SENSe]:SEMAsk:OFFSet[n]:LIST:BANDwidth BWIDth:AUTO OFF ON 0 1,OFF ON 0 1,OFF ON 0 1,OFF ON 0 1,OFF ON 0 1	470
[:SENSe]:SEMAsk:OFFSet[n]:LIST:BANDwidth BWIDth:AUTO?	470
[:SENSe]:SEMAsk:OFFSet[n]:LIST:BANDwidth BWIDth:IMULti <integer>,<integer>,<integer>,<integer>,<integer>	471
[:SENSe]:SEMAsk:OFFSet[n]:LIST:BANDwidth BWIDth:IMULti?	471
[:SENSe]:SEMAsk:OFFSet[n]:LIST:BANDwidth BWIDth?	469
[:SENSe]:SEMAsk:OFFSet[n]:LIST:FREQuency:START <f_offset>,<f_offset>,<f_offset>,<f_offset>,<f_offset>	472
[:SENSe]:SEMAsk:OFFSet[n]:LIST:FREQuency:START?	472
[:SENSe]:SEMAsk:OFFSet[n]:LIST:FREQuency:STEP <f_offset>,<f_offset>,<f_offset>,<f_offset>,<f_offset>	473
[:SENSe]:SEMAsk:OFFSet[n]:LIST:FREQuency:STEP:AUTO OFF ON 0 1,OFF ON 0 1,OFF ON 0 1,OFF ON 0 1,OFF ON 0 1	473
[:SENSe]:SEMAsk:OFFSet[n]:LIST:FREQuency:STEP:AUTO?	474
[:SENSe]:SEMAsk:OFFSet[n]:LIST:FREQuency:STEP?	473
[:SENSe]:SEMAsk:OFFSet[n]:LIST:FREQuency:STOP <f_offset>,<f_offset>,<f_offset>,<f_offset>,<f_offset>	474
[:SENSe]:SEMAsk:OFFSet[n]:LIST:FREQuency:STOP?	474

List of Commands

[:SENSe]:SEMAsk:OFFSet[n]:LIST:RATTenuation <rel_power>,<rel_power>,<rel_power>,<rel_power>,<rel_power>.....	475
[:SENSe]:SEMAsk:OFFSet[n]:LIST:RATTenuation?	475
[:SENSe]:SEMAsk:OFFSet[n]:LIST:SIDE BOTH NEGative POSitive, BOTH NEGative POSitive,BOTH NEGative POSitive, BOTH NEGative POSi- tive,BOTH NEGative POSitive.....	476
[:SENSe]:SEMAsk:OFFSet[n]:LIST:SIDE?	476
[:SENSe]:SEMAsk:OFFSet[n]:LIST:STARt:ABSolute <abs_power>,<abs_power>,<abs_power>,<abs_power>,<abs_power>	477
[:SENSe]:SEMAsk:OFFSet[n]:LIST:STARt:ABSolute?	477
[:SENSe]:SEMAsk:OFFSet[n]:LIST:STARt:RCARrier <rel_power>,<rel_power>,<rel_power>,<rel_power>,<rel_power>.....	478
[:SENSe]:SEMAsk:OFFSet[n]:LIST:STARt:RCARrier?	478
[:SENSe]:SEMAsk:OFFSet[n]:LIST:STATe OFF ON 0 1,OFF ON 0 1,OFF ON 0 1,OFF ON 0 1,OFF ON 0 1	479
[:SENSe]:SEMAsk:OFFSet[n]:LIST:STATe?	480
[:SENSe]:SEMAsk:OFFSet[n]:LIST:STOP:ABSolute <abs_power>,<abs_power>,<abs_power>,<abs_power>,<abs_power>	480
[:SENSe]:SEMAsk:OFFSet[n]:LIST:STOP:ABSolute:COUple OFF ON 0 1,OFF ON 0 1,OFF ON 0 1,OFF ON 0 1,OFF ON 0 1	481
[:SENSe]:SEMAsk:OFFSet[n]:LIST:STOP:ABSolute:COUple?	481
[:SENSe]:SEMAsk:OFFSet[n]:LIST:STOP:ABSolute?	480
[:SENSe]:SEMAsk:OFFSet[n]:LIST:STOP:RCARrier <rel_power>,<rel_power>,<rel_power>,<rel_power>,<rel_power>.....	482
[:SENSe]:SEMAsk:OFFSet[n]:LIST:STOP:RCARrier:COUple OFF ON 0 1,OFF ON 0 1,OFF ON 0 1,OFF ON 0 1,OFF ON 0 1	483
[:SENSe]:SEMAsk:OFFSet[n]:LIST:STOP:RCARrier:COUple?	483
[:SENSe]:SEMAsk:OFFSet[n]:LIST:STOP:RCARrier?	482
[:SENSe]:SEMAsk:OFFSet[n]:LIST:TEST ABSolute AND OR RELative,ABSolute AND OR RELative, ABSolute AND OR RELative,ABSolute AND OR RELative, ABSolute AND OR RELative.....	484
[:SENSe]:SEMAsk:OFFSet[n]:LIST:TEST?	484
[:SENSe]:SEMAsk:REGion:LIST:BANDwidth BWIDth <res_bw>,<res_bw>,<res_bw>,<res_bw>,<res_bw>	486
[:SENSe]:SEMAsk:REGion:LIST:BANDwidth BWIDth:AUTO OFF ON 0 1,OFF ON 0 1,OFF ON 0 1,OFF ON 0 1,OFF ON 0 1	487

List of Commands

[:SENSe]:SEMAsk:REGion:LIST:BANDwidth BWIDth:AUTO?	487
[:SENSe]:SEMAsk:REGion:LIST:BANDwidth BWIDth?	486
[:SENSe]:SEMAsk:REGion:LIST:FREQuency:START <f_region>,<f_region>,<f_region>,<f_region>,<f_region>	487
[:SENSe]:SEMAsk:REGion:LIST:FREQuency:START?	487
[:SENSe]:SEMAsk:REGion:LIST:FREQuency:STEP <f_region>,<f_region>,<f_region>,<f_region>,<f_region>	488
[:SENSe]:SEMAsk:REGion:LIST:FREQuency:STEP:AUTO OFF ON 0 1,OFF ON 0 1,OFF ON 0 1,OFF ON 0 1,OFF ON 0 1	489
[:SENSe]:SEMAsk:REGion:LIST:FREQuency:STEP:AUTO?	489
[:SENSe]:SEMAsk:REGion:LIST:FREQuency:STEP?	488
[:SENSe]:SEMAsk:REGion:LIST:FREQuency:STOP <f_region>,<f_region>,<f_region>,<f_region>,<f_region>	490
[:SENSe]:SEMAsk:REGion:LIST:FREQuency:STOP?	490
[:SENSe]:SEMAsk:REGion:LIST:RATTenuation <rel_power>,<rel_power>,<rel_power>,<rel_power>,<rel_power>	490
[:SENSe]:SEMAsk:REGion:LIST:RATTenuation?	490
[:SENSe]:SEMAsk:REGion:LIST:STARt:ABSolute <abs_power>,<abs_power>	491
[:SENSe]:SEMAsk:REGion:LIST:STARt:ABSolute?	492
[:SENSe]:SEMAsk:REGion:LIST:STARt:RCARrier <rel_power>,<rel_power>,<rel_power>,<rel_power>,<rel_power>	492
[:SENSe]:SEMAsk:REGion:LIST:STARt:RCARrier?	492
[:SENSe]:SEMAsk:REGion:LIST:STATe OFF ON 0 1,OFF ON 0 1,OFF ON 0 1,OFF ON 0 1,OFF ON 0 1	493
[:SENSe]:SEMAsk:REGion:LIST:STATe?	493
[:SENSe]:SEMAsk:REGion:LIST:STOP:ABSolute <abs_power>,<abs_power>,<abs_power>,<abs_power>,<abs_power>	494
[:SENSe]:SEMAsk:REGion:LIST:STOP:ABSolute?	494
[:SENSe]:SEMAsk:REGion:LIST:STOP:RCARrier <rel_power>,<rel_power>,<rel_power>,<rel_power>,<rel_power>	496
[:SENSe]:SEMAsk:REGion:LIST:STOP:RCARrier:COUple OFF ON 0 1,OFF ON 0 1,OFF ON 0 1,OFF ON 0 1,OFF ON 0 1	497
[:SENSe]:SEMAsk:REGion:LIST:STOP:RCARrier:COUple?	497
[:SENSe]:SEMAsk:REGion:LIST:STOP:RCARrier?	496

List of Commands

[:SENSe]:SEMAsk:REGion:LIST:TEST ABSolute | AND | OR | RELative,ABSolute | AND | OR | RELa-
tive,
ABSolute | AND | OR | RELative,ABSolute | AND | OR | RELative,
ABSolute | AND | OR | RELative.497

[:SENSe]:SEMAsk:REGion:LIST:TEST?497

[:SENSe]:SEMAsk:REGion[n]:LIST:BANDwidth | BWIDth
<res_bw>,<res_bw>,<res_bw>,<res_bw>,<res_bw>486

[:SENSe]:SEMAsk:REGion[n]:LIST:BANDwidth | BWIDth:AUTO
OFF | ON | 0 | 1,OFF | ON | 0 | 1,OFF | ON | 0 | 1,OFF | ON | 0 | 1,OFF | ON | 0 | 1486

[:SENSe]:SEMAsk:REGion[n]:LIST:BANDwidth | BWIDth:AUTO?487

[:SENSe]:SEMAsk:REGion[n]:LIST:BANDwidth | BWIDth?486

[:SENSe]:SEMAsk:REGion[n]:LIST:FREQuency:STARt
<f_region>,<f_region>,<f_region>,<f_region>,<f_region>487

[:SENSe]:SEMAsk:REGion[n]:LIST:FREQuency:STARt?487

[:SENSe]:SEMAsk:REGion[n]:LIST:FREQuency:STEP
<f_region>,<f_region>,<f_region>,<f_region>,<f_region>488

[:SENSe]:SEMAsk:REGion[n]:LIST:FREQuency:STEP:AUTO
OFF | ON | 0 | 1,OFF | ON | 0 | 1,OFF | ON | 0 | 1,OFF | ON | 0 | 1,OFF | ON | 0 | 1489

[:SENSe]:SEMAsk:REGion[n]:LIST:FREQuency:STEP:AUTO?489

[:SENSe]:SEMAsk:REGion[n]:LIST:FREQuency:STEP?488

[:SENSe]:SEMAsk:REGion[n]:LIST:FREQuency:STOP
<f_region>,<f_region>,<f_region>,<f_region>,<f_region>489

[:SENSe]:SEMAsk:REGion[n]:LIST:FREQuency:STOP?490

[:SENSe]:SEMAsk:REGion[n]:LIST:RATTenuation
<rel_power>,<rel_power>,<rel_power>,<rel_power>,<rel_power>.490

[:SENSe]:SEMAsk:REGion[n]:LIST:RATTenuation?490

[:SENSe]:SEMAsk:REGion[n]:LIST:STARt:ABSolute
<abs_power>,<abs_power>491

[:SENSe]:SEMAsk:REGion[n]:LIST:STARt:ABSolute?491

[:SENSe]:SEMAsk:REGion[n]:LIST:STARt:RCARrier
<rel_power>,<rel_power>,<rel_power>,<rel_power>,<rel_power>.492

[:SENSe]:SEMAsk:REGion[n]:LIST:STARt:RCARrier?492

[:SENSe]:SEMAsk:REGion[n]:LIST:STATe
OFF | ON | 0 | 1,OFF | ON | 0 | 1,OFF | ON | 0 | 1,OFF | ON | 0 | 1,OFF | ON | 0 | 1493

[:SENSe]:SEMAsk:REGion[n]:LIST:STATe?493

[:SENSe]:SEMAsk:REGion[n]:LIST:STOP:ABSolute

List of Commands

<abs_power>,<abs_power>,<abs_power>,<abs_power>,<abs_power>	494
[::SENSE]:SEMAsk:REGion[n]:LIST:STOP:ABSolute:COUple OFF ON 0 1,{OFF ON 0 1}	495
[::SENSE]:SEMAsk:REGion[n]:LIST:STOP:ABSolute:COUple?	495
[::SENSE]:SEMAsk:REGion[n]:LIST:STOP:ABSolute?	494
[::SENSE]:SEMAsk:REGion[n]:LIST:STOP:RCARrier <rel_power>,<rel_power>,<rel_power>,<rel_power>,<rel_power>	496
[::SENSE]:SEMAsk:REGion[n]:LIST:STOP:RCARrier:COUple OFF ON 0 1,OFF ON 0 1,OFF ON 0 1,OFF ON 0 1,OFF ON 0 1	497
[::SENSE]:SEMAsk:REGion[n]:LIST:STOP:RCARrier:COUple?	497
[::SENSE]:SEMAsk:REGion[n]:LIST:STOP:RCARrier?	496
[::SENSE]:SEMAsk:REGion[n]:LIST:TEST ABSolute AND OR RELative,ABSolute AND OR RELative, ABSolute AND OR RELative,ABSolute AND OR RELative, ABSolute AND OR RELative	497
[::SENSE]:SEMAsk:REGion[n]:LIST:TEST?	497
[::SENSE]:SEMAsk:SEGMENT OFFSet REGion	498
[::SENSE]:SEMAsk:SEGMENT:TYPE ACPr SEMAsk	499
[::SENSE]:SEMAsk:SEGMENT:TYPE?	499
[::SENSE]:SEMAsk:SEGMENT?	498
[::SENSE]:SEMAsk:SWEep:TIME <time> <no. of chips>	499
[::SENSE]:SEMAsk:SWEep:TIME:OFFSet <time> <no. of chips>	499
[::SENSE]:SEMAsk:SWEep:TIME:OFFSet?	499
[::SENSE]:SEMAsk:SWEep:TIME?	499
[::SENSE]:SEMAsk:TRIGger:SOURce EXTernal[1] EXTernal2 FRAME IMMEDIATE LINE	500
[::SENSE]:SEMAsk:TRIGger:SOURce?	500
[::SENSE]:SEMAsk:TYPE PSDRef	500
[::SENSE]:SEMAsk:TYPE?	500
[::SENSE]:SPECTrum:ACQuisition:PACKing AUTO LONG MEDium SHORt	502
[::SENSE]:SPECTrum:ACQuisition:PACKing?	502
[::SENSE]:SPECTrum:ADC:DITHer[:STATe] AUTO ON OFF 2 1 0	502
[::SENSE]:SPECTrum:ADC:DITHer[:STATe]?	502
[::SENSE]:SPECTrum:ADC:RANGe AUTO APEak APLock M6 P0 P6 P12 P18 P24	502

List of Commands

[:SENSe]:SPECTrum:ADC:RANGe AUTO APEak APLOCK NONE P0 P6 P12 P18503
[:SENSe]:SPECTrum:ADC:RANGe?503
[:SENSe]:SPECTrum:AVERAge:CLEAr504
[:SENSe]:SPECTrum:AVERAge:COUNt <integer>504
[:SENSe]:SPECTrum:AVERAge:COUNt?504
[:SENSe]:SPECTrum:AVERAge:TCONtrol EXPONential REPeat.505
[:SENSe]:SPECTrum:AVERAge:TCONtrol?505
[:SENSe]:SPECTrum:AVERAge:TYPE LOG MAXimum MINimum RMS SCALar505
[:SENSe]:SPECTrum:AVERAge:TYPE?505
[:SENSe]:SPECTrum:AVERAge[:STATe] OFF ON 0 1505
[:SENSe]:SPECTrum:AVERAge[:STATe]?505
[:SENSe]:SPECTrum:BANDwidth BWIDth:IF:AUTO OFF ON 0 1506
[:SENSe]:SPECTrum:BANDwidth BWIDth:IF:AUTO?506
[:SENSe]:SPECTrum:BANDwidth BWIDth:IF:FLATness OFF ON 0 1506
[:SENSe]:SPECTrum:BANDwidth BWIDth:IF:FLATness?506
[:SENSe]:SPECTrum:BANDwidth BWIDth:PADC OFF ON 0 1507
[:SENSe]:SPECTrum:BANDwidth BWIDth:PADC?507
[:SENSe]:SPECTrum:BANDwidth BWIDth:PFFT:TYPE FLAT GAUSSian.508
[:SENSe]:SPECTrum:BANDwidth BWIDth:PFFT:TYPE?508
[:SENSe]:SPECTrum:BANDwidth BWIDth:PFFT[:SIZE] <freq>507
[:SENSe]:SPECTrum:BANDwidth BWIDth:PFFT[:SIZE]?507
[:SENSe]:SPECTrum:BANDwidth BWIDth[:RESolution] <freq>508
[:SENSe]:SPECTrum:BANDwidth BWIDth[:RESolution]:AUTO OFF ON 0 1509
[:SENSe]:SPECTrum:BANDwidth BWIDth[:RESolution]:AUTO?509
[:SENSe]:SPECTrum:BANDwidth BWIDth[:RESolution]?508
[:SENSe]:SPECTrum:DECimate[:FACTor] <integer>509
[:SENSe]:SPECTrum:DECimate[:FACTor]?509
[:SENSe]:SPECTrum:FFT:LENGth <integer>510
[:SENSe]:SPECTrum:FFT:LENGth:AUTO OFF ON 0 1510
[:SENSe]:SPECTrum:FFT:LENGth:AUTO?510
[:SENSe]:SPECTrum:FFT:LENGth?510

List of Commands

[[:SENSe]:SPECTrum:FFT:RBWPoints <real>	511
[[:SENSe]:SPECTrum:FFT:RBWPoints?	511
[[:SENSe]:SPECTrum:FFT:WINDow:DELay <real>	511
[[:SENSe]:SPECTrum:FFT:WINDow:DELay?	511
[[:SENSe]:SPECTrum:FFT:WINDow:LENGth <integer>	512
[[:SENSe]:SPECTrum:FFT:WINDow:LENGth?	512
[[:SENSe]:SPECTrum:FFT:WINDow[:TYPE] BH4Tap BLACkman FLATtop GAUSSian HAM- Ming HANNing KB70 KB90 KB110 UNIFORM	512
[[:SENSe]:SPECTrum:FFT:WINDow[:TYPE]?	512
[[:SENSe]:SPECTrum:FREQuency:SPAN <freq>	513
[[:SENSe]:SPECTrum:FREQuency:SPAN?	513
[[:SENSe]:SPECTrum:SWEep:TIME:AUTO OFF ON 0 1	514
[[:SENSe]:SPECTrum:SWEep:TIME:AUTO	514
[[:SENSe]:SPECTrum:SWEep:TIME?	513
[[:SENSe]:SPECTrum:SWEep:TIME[:VALue] <time>	513
[[:SENSe]:SPECTrum:TRIGger:SOURce EXTernal[1] EXTernal2 FRAME IF LINE IMMEdi- ate RFBurst	514
[[:SENSe]:SPECTrum:TRIGger:SOURce?	514
[[:SENSe]:TCDPower:ACODE AUTO COMBination PREDeFined	516
[[:SENSe]:TCDPower:ACODE:ACK OFF ON 0 1	516
[[:SENSe]:TCDPower:ACODE:ACK?	516
[[:SENSe]:TCDPower:ACODE:DATA OFF ON 0 1	516
[[:SENSe]:TCDPower:ACODE:DATA?	516
[[:SENSe]:TCDPower:ACODE:DRC OFF ON 0 1	517
[[:SENSe]:TCDPower:ACODE:DRC?	517
[[:SENSe]:TCDPower:ACODE:PILot OFF ON 0 1	517
[[:SENSe]:TCDPower:ACODE:PILot?	517
[[:SENSe]:TCDPower:ACODE?	516
[[:SENSe]:TCDPower:ADC:RANGe AUTO APEak APLock NONE P0 P6 P12 P18 P24 M6	517
[[:SENSe]:TCDPower:ADC:RANGe?	517
[[:SENSe]:TCDPower:CAPTure:TIME <integer>	518
[[:SENSe]:TCDPower:CAPTure:TIME?	518

List of Commands

[:SENSe]:TCDPower:CRATe <freq>519
[:SENSe]:TCDPower:CRATe?519
[:SENSe]:TCDPower:SPECTrum NORMAL INVert520
[:SENSe]:TCDPower:SPECTrum?520
[:SENSe]:TCDPower:SYNC:ILCMask <long_integer>520
[:SENSe]:TCDPower:SYNC:ILCMask?520
[:SENSe]:TCDPower:SYNC:QLCMask <long_integer>520
[:SENSe]:TCDPower:SYNC:QLCMask?520
[:SENSe]:TCDPower:TRIGger:SOURce EXTernal[1] EXTernal2 IMMEDIATE RFBurst IF FRAME	519
[:SENSe]:TCDPower:TRIGger:SOURce?519
[:SENSe]:TRHO:ACODE AUTO COMBination PREDefined521
[:SENSe]:TRHO:ACODE:ACK OFF ON 0 1521
[:SENSe]:TRHO:ACODE:ACK?521
[:SENSe]:TRHO:ACODE:DATA OFF ON 0 1521
[:SENSe]:TRHO:ACODE:DATA?521
[:SENSe]:TRHO:ACODE:DRC OFF ON 0 1522
[:SENSe]:TRHO:ACODE:DRC?522
[:SENSe]:TRHO:ACODE:PILOt OFF ON 0 1522
[:SENSe]:TRHO:ACODE:PILOt?522
[:SENSe]:TRHO:ACODE?521
[:SENSe]:TRHO:ADC:RANGe AUTO APEak APLock NONE P0 P6 P12 P18 P24 M6522
[:SENSe]:TRHO:ADC:RANGe?522
[:SENSe]:TRHO:ASET:THReshold <numeric>524
[:SENSe]:TRHO:ASET:THReshold?524
[:SENSe]:TRHO:AVERAge:COUNT <integer>524
[:SENSe]:TRHO:AVERAge:COUNT?524
[:SENSe]:TRHO:AVERAge:TCONtrol EXPonential REPeat524
[:SENSe]:TRHO:AVERAge:TCONtrol?524
[:SENSe]:TRHO:AVERAge[:STATe] OFF ON 0 1524
[:SENSe]:TRHO:AVERAge[:STATe] OFF ON 0 1525

List of Commands

[[:SENSe]:TRHO:AVERage[:STATe]?	524
[[:SENSe]:TRHO:AVERage[:STATe]?	525
[[:SENSe]:TRHO:CRATe <freq>	525
[[:SENSe]:TRHO:CRATe?	525
[[:SENSe]:TRHO:SPECtrum NORMAl INVert	525
[[:SENSe]:TRHO:SPECtrum?	526
[[:SENSe]:TRHO:SYNC:ILCMask <long_integer>	526
[[:SENSe]:TRHO:SYNC:ILCMask?	526
[[:SENSe]:TRHO:SYNC:QLCMask <long_integer>	526
[[:SENSe]:TRHO:SYNC:QLCMask?	526
[[:SENSe]:TRHO:TRIGger:SOURce EXTernal[1] EXTernal2 IMMEDIATE RFBURSt IF FRAMe	526
[[:SENSe]:TRHO:TRIGger:SOURce?	526
[[:SENSe]:WAVeform:ACQuisition:PACKing AUTO LONG MEDium SHORt	528
[[:SENSe]:WAVeform:ACQuisition:PACKing?	528
[[:SENSe]:WAVeform:ADC:DITHer[:STATe] OFF ON 0 1	528
[[:SENSe]:WAVeform:ADC:DITHer[:STATe]?	528
[[:SENSe]:WAVeform:ADC:FILTer[:STATe] OFF ON 0 1	528
[[:SENSe]:WAVeform:ADC:FILTer[:STATe]?	528
[[:SENSe]:WAVeform:ADC:RANGe AUTO APEak APLock GROund M6 P0 P6 P12 P18 P24	529
[[:SENSe]:WAVeform:ADC:RANGe AUTO APEak APLock GROund NONE P0 P6 P12 P18	529
[[:SENSe]:WAVeform:ADC:RANGe?	529
[[:SENSe]:WAVeform:APERture?	530
[[:SENSe]:WAVeform:AVERage:COUNt <integer>	530
[[:SENSe]:WAVeform:AVERage:COUNt?	530
[[:SENSe]:WAVeform:AVERage:TCONtrol EXPonential REPeat	531
[[:SENSe]:WAVeform:AVERage:TCONtrol?	531
[[:SENSe]:WAVeform:AVERage:TYPE LOG MAXimum MINimum RMS SCALar	531
[[:SENSe]:WAVeform:AVERage:TYPE?	531
[[:SENSe]:WAVeform:AVERage[:STATe] OFF ON 0 1	530
[[:SENSe]:WAVeform:AVERage[:STATe]?	530

List of Commands

[[:SENSE]:WAVEform:BANDwidth:RESolution]:ACTual?532
[[:SENSE]:WAVEform:BANDwidth BWIDth[:RESolution] <freq>.532
[[:SENSE]:WAVEform:BANDwidth BWIDth[:RESolution]:TYPE FLATtop GAUSSian533
[[:SENSE]:WAVEform:BANDwidth BWIDth[:RESolution]:TYPE?533
[[:SENSE]:WAVEform:BANDwidth BWIDth[:RESolution]?532
[[:SENSE]:WAVEform:DECimate:STATe OFF ON 0 1534
[[:SENSE]:WAVEform:DECimate:STATe?534
[[:SENSE]:WAVEform:DECimate[:FACTor] <integer>.533
[[:SENSE]:WAVEform:DECimate[:FACTor]?533
[[:SENSE]:WAVEform:SWEep:TIME <time>534
[[:SENSE]:WAVEform:SWEep:TIME?534
[[:SENSE]:WAVEform:TRIGger:SOURce EXTernal[1] EXTernal2 FRAME IF IMMEDIATE LINE RFBurst.534
[[:SENSE]:WAVEform:TRIGger:SOURce?.534

1 Understanding 1xEV-DO

What Is the 1xEV-DO System?

1xEV-DO is the name applied to the first evolution (1xEV) of a 3GPP2 communications system optimized for data only (-DO). As 1xEV-DO has evolved from the cdma2000 voice system and has structural similarity to cdma2000, this discussion will also describe the differences between 1xEV-DO and cdma2000.

RF Characteristics

1xEV-DO uses what is known as High Rate Packet Data, using the same final spread rate of 1.2288 Mcps as does cdma2000 SR1. It also uses the same digital filter to reduce the final modulation bandwidth, with the result that 1xEV-DO is spectrally compatible with cdma2000 SR1. Both 1xEV-DO and cdma2000 SR1 can utilize the same amplifiers, combiners, and antennas to reduce the installation cost of 1xEV-DO.

Although 1xEV-DO is compatible with much existing cdma2000 infrastructure, the two systems may not simultaneously occupy the same channel. Each 1xEV-DO channel requires a paired 1.25 MHz clear channel, therefore it can not be overlaid with cdma2000 channels.

Access Terminal & Access Network

There is an inclusion of the new terminology in 1xEV-DO as follows:

- Access Terminal (AT) - A device equipped with a radio modem and a data interface which allows the user to access a packet data network through the 1xEV-DO access network.
- Access Network (AN) - A network equipment that provides data connectivity between a packet-switched data network such as Internet and the ATs.

Forward Link

1xEV-DO relies on the Global Positioning System (GPS) for intercell synchronization, in the same manner as cdma2000. The 1xEV-DO system is well suited for data transmission in the forward link, as it is optimized for high speed packet data communications from ANs (base stations) to ATs (mobile stations). Average delivery rates of about 600 kHz per sector on a continuous basis have been demonstrated. When compared to the recent IS-95-B design in cdma2000, 1xEV-DO shows about a 6 times improvement in the overall network data rate.

The largest contribution to overall increased data throughput is the ability of 1xEV to negotiate for increased data rates for individual users or mobiles, as only one user is served at a time. This and other

contributing factors are described in detail in the Design Elements section below.

Frame Structure

The frame structure is different from that used for cdma2000 and IS-95 systems, as they are based on 20 ms frames set by the codec for speech. The frame period for 1xEV-DO is 26.667 ms, which is also the period of one pilot channel. Each frame is divided up into 16 slots of 1.667 ms.

Design Elements

When compared to a voice communication system of cdma2000, the following design elements of the forward link contribute to raise the data rate:

- Full power - The cell is always at full power, resulting in no overhead needed for statistical variations of multiple users.
- Best serving cell - When in soft handoff, the mobile selects the best serving cell and can only request and receive data from that cell.
- Efficient data delivery - The base station can send data to a mobile at times when its rate request is higher than the running average of the base station, and will avoid sending data when the requested rate is lower than the running average.

The forward link is always transmitted at its full power, using a rate control scheme instead of a power control scheme, as in cdma2000. The data is TDM (time division multiplexed) to the various users or mobiles, with only one being served at any time. Each mobile measures signal-to-noise ratio (S/N) on the forward link pilot every slot, 1.667 ms, and sends a data rate request to the base station every 1.667 ms. The base station decides which mobile should be served next. The maximum data transfer from the network will be achieved if only the most favorable links get served, however, this is accomplished at the expense of the distant users.

Forward Channel TDM Structure

The following four different channels are used and are Time Division Multiplexed (TDM):

- Traffic Channel - The data following the turbo coder is scrambled by mixing with a PN sequence, the initial state of which is based on known parameters, and is unique for each user. At the same initial value of the PN sequence, every packet starts. QPSK modulation is used for data rate up to 1.2288 Mbps. Higher order modulation, with either 8PSK with 3 bits per symbol or 16QAM with 4 bits per

symbol, is used for higher data rates. The levels of the I and Q symbols are mathematically chosen so that the average power becomes 1. The I and Q channels are mapped into 16 parallel Walsh covers, each of length 16. The I and Q outputs with the Walsh covers signals are added.

- Preamble - At the beginning of the transmission to one user, there is a preamble that is embedded in the data. This preamble contains the user ID for the data, and its repeat rate is determined by the data rate; lower data rates require higher repeat values. At its largest, the preamble will fill more than a half the first slot.
- Medium Access Control (MAC) - This layer consists of the reverse power control (RPC) and the reverse activity (RA). The power control bits are sent in parallel to all mobiles with an open connection. Each one is assigned a different 64-bit Walsh code which gets transmitted on either the I or Q channel. The codes 0 through 3 are reserved. The Walsh code 4 is the RA cover. The Walsh codes 5 through 63 are allocated to RPC. One Walsh code is allocated for power control to each active reverse link. Power control bits for all of the reverse links are sent in parallel as part of the MAC channel. These are made of 4 repetitions of an assigned Walsh code of length 64. The RA channel is used to indicate that the sector is busy decoding multiple reverse link signals.
- Pilot - The pilot signal is gated on for only 192 chips per slot. The differentiator between the cell and the sector is still the PN offset of the pilot channel.

The data structure per slot can be illustrated as follows:

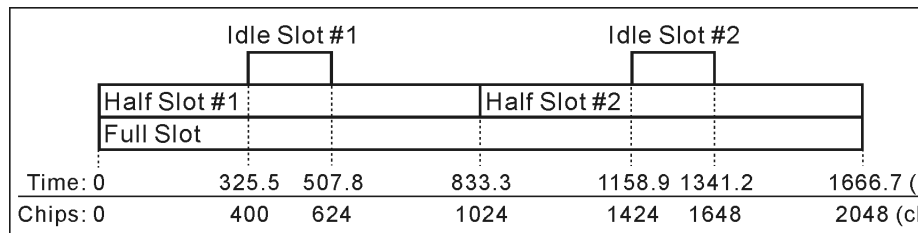

Reverse Link Coding

The reverse link for 1xEV-DO has a structure similar to that for cdma2000, except that in addition to a data channel, the following channels are also included:

- Reverse Rate Indication (RRI) - This replaces with the power control bits to indicate of which data rate is requested by the mobile.
- Data Request Channel (DRC) - This contains a 4 bit word in each slot to allow the choice of up to 16 different transmission rates. Different Walsh covers are used to indicate which PN offset in the active set is preferred for transmission.
- Ack Channel - This acknowledgement channel is only transmitted after the mobile detects a frame with its preamble, meaning the packet is directed to that mobile. The 1 bit on this channel, which is transmitted for a half slot, is used to indicate a successful reception or an erasure.

The Pilot in 1xEV-DO is still punctured but the information carried is different:

In cdma2000, the Pilot is punctured in a 3:1 ratio (3 Pilot, 1 Data) to carry power control bits. The puncture period is 1 Power Control Group, or 1.25 ms. The data rate for PCB is 16 bits per 20 ms frame.

In 1xEV-DO, the puncture pattern is 7:1 on each slot (7 Pilot, 1 Data). The underlying data is coded, and the transmission rate is 3 bits per 26.667 ms frame.

In 1xEV all signaling is performed on the data channel so there is no Dedicated Control Channel. The data channel can support 5 data rates which are separated in powers of 2 (256 through 4096 bits, or 9.6 through 153.6 kbps). These rates are achieved by varying the repeat factor. The highest rate uses a Turbo coder with lower gain.

Reverse Link Scrambling

The Pilot, ACK, DRC, and Data channels are added with each other in a manner that maps some into I and some into Q for eventual spreading. The final spreading is made similarly to cdma2000 with HPSK. In 1xEV-DO, the long code used for spreading is seeded with a fixed pattern at the start of every Pilot sequence, every 26.667 ms. There are separate masks, 42 bits long, for the I and Q long spreading codes. In cdma2000, the long code generator is based on system time, or in other words a continuous clock.

Standard Documents

1xEV-DO is defined in the following Telecommunications Industry Association (TIA) and Electronics Industry Alliance (EIA) document:

3GPP2 C.S0024 Version 2.01 cdma2000 High Rate Packet Data Air Interface Specification

3GPP2 C.S0032 Recommended Minimum Performance Standards for cdma2000 High Rate Packet Data Access Network

3GPP2 C.S0033 Recommended Minimum Performance Standards for cdma2000 High Rate Packet Data Access Terminal

TIA/EIA/IS-856 cdma2000 High Rate Packet Data Air Interface Specification

Compatibility with IS-2000

When interpreting TIA/EIA/IS-2000 in the context of TIA/EIA/IS-856, the terms for TIA/EIA/IS-2000 should be mapped as follows:

TIA/EIA/IS-2000	TIA/EIA/IS-856
BS	AN
Base Station	Access Network
BSC	AN
Base Station Control	Access Network
Call	Connection
MS	AT
Mobile Station	Access Terminal

What Does the Agilent PSA Series and VSA E4406A Option 204 Do?

This instrument can help determine if a 1xEV-DO transmitter is working correctly. Installing the optional measurement personality Option 204, the instrument automatically makes measurements using the measurement methods and limits defined in the standards (TIA/EIA/IS-2000.2-A Physical Layer Standard for cdma2000 Spread Spectrum Systems). The detailed results displayed by the measurements allow you to analyze 1xEV-DO system performance. You may alter the measurement parameters for specialized analysis.

For infrastructure test, the instrument will test base station transmitters in a non-interfering manner by means of a coupler or power splitter.

This instrument makes the following measurements:

- Channel Power
- Intermodulation
- Power versus Time
- Spurious Emissions and ACP
- Occupied Bandwidth
- Code Domain Power
- Modulation Accuracy (Composite Rho)
- QPSK EVM
- Power Statistics CCDF
- Spectrum (Frequency Domain)
- Waveform (Time Domain)

Other Sources of Measurement Information

Additional measurement application information is available through your local Agilent Technologies sales and service office. The following application notes treat digital communications measurements in much greater detail than is discussed in this measurement guide.

- Application Note 1298
Digital Modulation in Communications Systems - An Introduction
Agilent part number 5965-7160E
- Application Note 1311
Understanding CDMA Measurements for Base Stations and Their Components
Agilent part number 5968-0953E
- Application Note 1325
Performing cdma2000 Measurements Today
Agilent part number 5968-5858E

Instrument Updates at <http://www.agilent.com>

These web locations can be used to access the latest information about the instrument, including the latest firmware version.

<http://www.agilent.com/find/psa>

<http://www.agilent.com/find/vsa>

2

Getting Started

This chapter introduces the basic features, including the front panel keys, and provides simplified procedures for making various measurements on 1xEV-DO BTS (forward link) and MS (reverse link).

Instrument Front Panel Highlights

The major functional keys on the front panel are located as illustrated below, and each of these operation is explained on the next page.

Figure 2-1 E4406A Selected Front Panel Key Locations

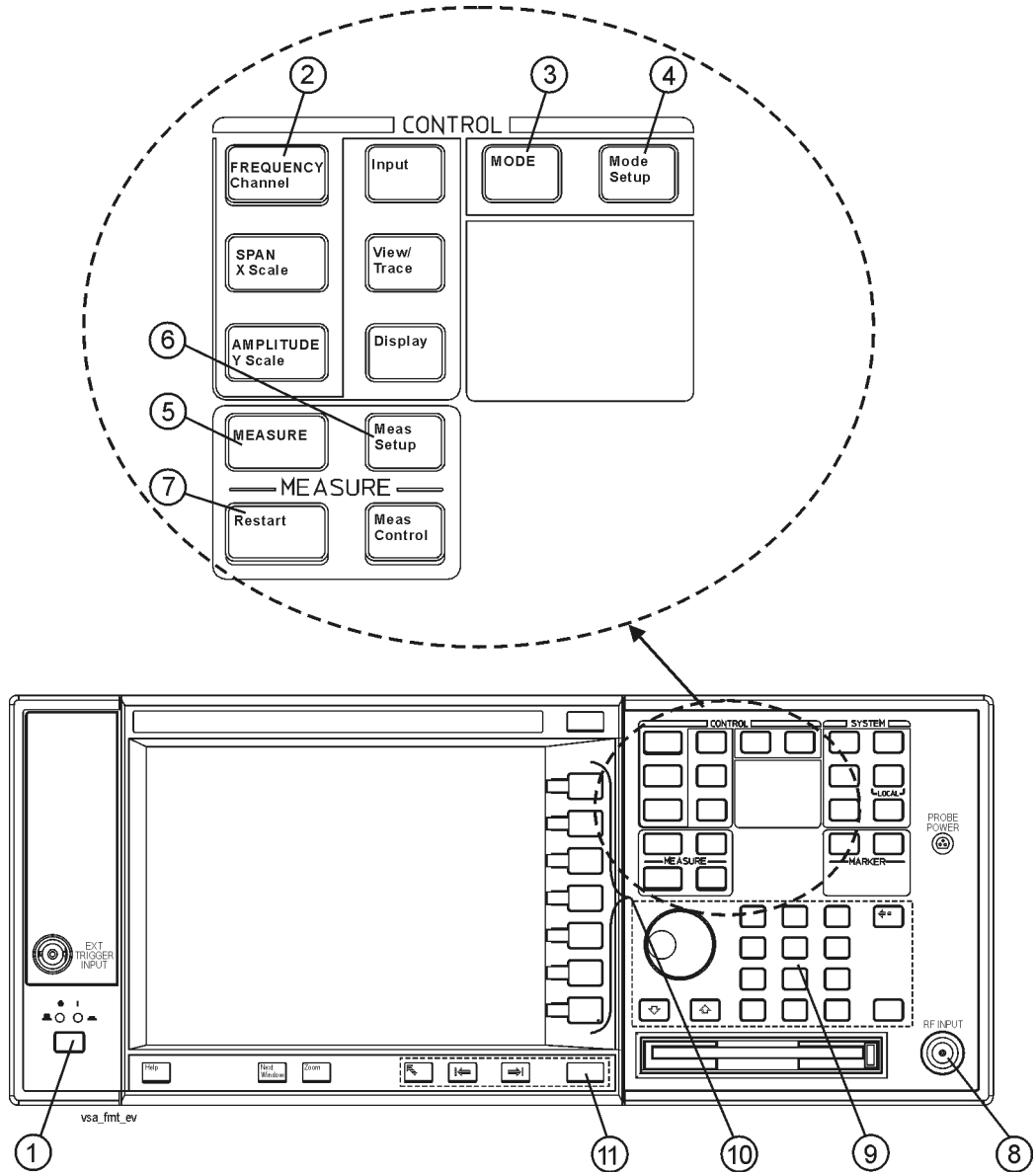
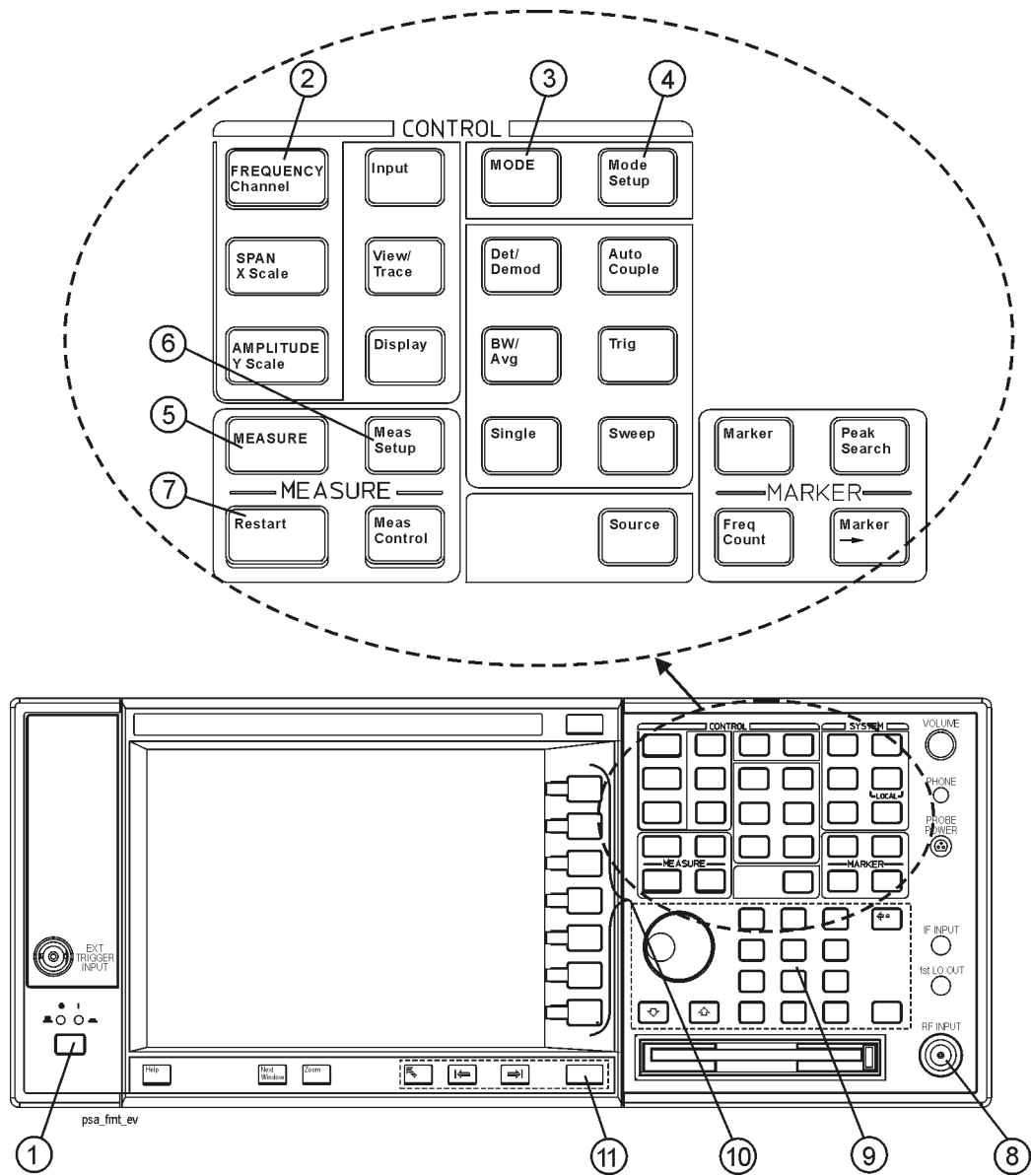

Figure 2-2 PSA Selected Front Panel Key Locations



1. The **On/Off** switch toggles the power between on and off. A green LED will light when the instrument has been turned on. When energized in the standby mode a yellow LED is lit above the **On/Off** switch.
2. **FREQUENCY Channel** accesses the softkey that controls the center frequency or channel number. These parameters apply to all measurements in the current mode.
3. **MODE** accesses the softkey menu to select one of the radio systems installed in the instrument. Each mode is independent from all other modes.
4. **Mode Setup** accesses softkeys that affect parameters that are specific to the current mode and affect all measurements within that mode.
5. **MEASURE** accesses the menus to initiate one of the various measurements that are specific to the current mode.
6. **Meas Setup** accesses the menus of test parameters that are specific to the current measurement.
7. **Restart** causes the measurement, of which process is currently halted, to start again from the initial process according to the current measurement setup parameters.
8. The **RF INPUT** port allows you to apply an external RF signal.
9. The **Data Entry** keypad is used to enter numeric values to parameters. A value from this keypad will be displayed in the active function area of the screen, then the value will become valid for the current measurement upon pressing the **Enter** key or selecting a unit of measurement depending on the parameter.
10. The **Softkeys** allow you either to activate a feature or to access a further softkey menu. An arrow on the right side of a softkey label indicates that the key has a further selection menu. The active softkey is highlighted, however, grayed-out keys are currently unavailable for use or are only to show information. If a softkey menu has multiple pages, further pages will be accessed by pressing the **More** key which is placed at the bottom of a menu.
11. **Return** allows you to exit from the current menu and display the previous menu. If you are on the first page of a multiple-page menu (the menu with **More (1 of 3)** for example), the **Return** key will exit from that menu. When you activate another measurement, the return list is cleared. The **Return** key will not return you to the previously activated mode, nor will it alter any values you have entered on previous menus.

Making a Measurement

This instrument enables you to make a wide variety of measurements on digital communications equipment using the **Basic Mode** (for E4406A), or the **Spectrum Analysis Mode** (for PSA) measurement capabilities. It also has optional measurement personalities that make measurements based on established industry standards.

To set up the instrument to make measurements, you need to:

1. Press **MODE** to select a personality which corresponds to a digital communications format, like cdma2000, W-CDMA, or EDGE. Or use the Basic mode to make measurements on signals with non-standard formats. After selecting the mode, make any required adjustments to the mode settings by pressing **Mode Setup**.
2. Press **MEASURE** to select a specific measurement to be performed, like ACP, Channel Power, or EVM, and so forth. After selection of your measurement, make any required adjustments to the measurement settings by pressing **Meas Setup**.

Depending on the current settings of **Meas Control**, the instrument will begin making the selected measurements. The resulting data will be shown on the display or available for export.

3. Press **Trace/View** to display the data from the current measurement. Depending on the mode and measurement selected, various graphical and tabular presentations are available.

If you have a problem, and get an error message, see the “If You Have a Problem” section in each measurement description.

The main keys used in the three steps are shown in the table below.

Step	Primary Key	Setup Keys	Related Keys
1. Select & setup a mode	MODE	Mode Setup, Input (E4406A), Input/Output (PSA), FREQUENCY Channel	System
2. Select & setup a measurement	MEASURE	Meas Setup	Meas Control, Restart
3. Select & setup a view	View/Trace (E4406A), Trace/View (PSA)	SPAN X Scale, AMPLITUDE Y Scale, Display, Next Window, Zoom	File, Save, Print, Print Setup, Marker, Search (E4406A), Peak Search (PSA)

A setting may be reset at any time, and will be in effect on the next measurement cycle or View.

Start Making Channel Power Measurements

This section explains how to make a channel power measurement on a 1xEV-DO base station. This test measures the total RF power present in the channel. The results are displayed graphically as well as in total power (dB) and power spectral density (dBm/Hz).

Configuring the Measurement System

The access network (BTS) under test has to be set to transmit the RF power remotely through the system controller. This transmitting signal is connected to the instrument's RF input port. Connect the equipment as shown below:

Figure 2-3

Channel Power Measurement System

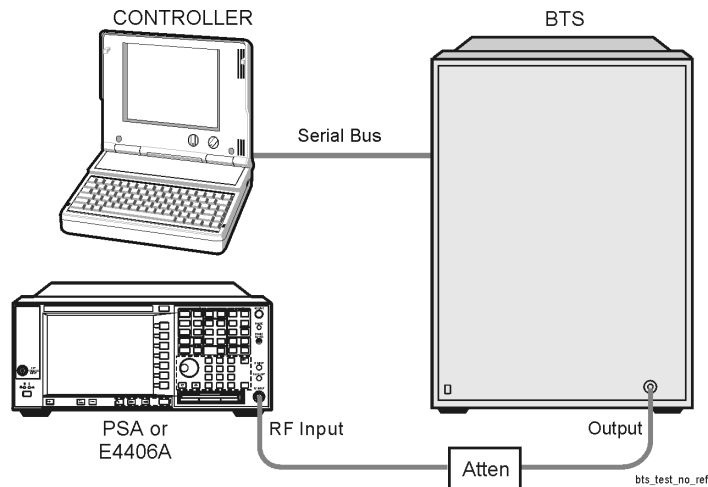

1. Using the appropriate cables, adapters, and attenuators, connect the output signal from the BTS to the RF input port of the instrument.
2. Connect the system controller to the BTS through the serial bus cable to control the BTS operation.

Setting Up the BTS

From the system controller, perform all of the functions required for the BTS to transmit the RF signal.

- BTS
 - Frequency: 1,935.000 MHz (preferred channel number 100)
(= $100 \times 0.050 + 1930.000$ MHz)
 - Output Power: Specified maximum output power level

Measurement Procedure

- Step 1.** Press the **Preset** key to preset the instrument.
- Step 2.** Press the **System, Reference, Freq Ref** keys to toggle the frequency reference to EXT, if required. In the annunciator bar you will see EXT REF displayed in green.
- Step 3.** Press the **MODE, 1xEV-DO** keys to enable the 1xEV-DO measurements.
- Step 4.** Press the **Mode Setup, Input, Max Total Pwr** to enter the estimated maximum power from the BTS.
- Step 5.** Press the **Input Atten** and/or **Ext RF Atten** to enter the appropriate attenuation values depending on the estimated maximum power from the BTS.
- Step 6.** Press the **FREQUENCY Channel, 1935, MHz** keys to set the center frequency to 1,935.000 MHz.
- Step 7.** Press the **MEASURE, Channel Power** keys to initiate the channel power measurement.

The Channel Power measurement result should look like the next figure. The graph window and the text window showing the absolute power and its mean power spectral density values are displayed.

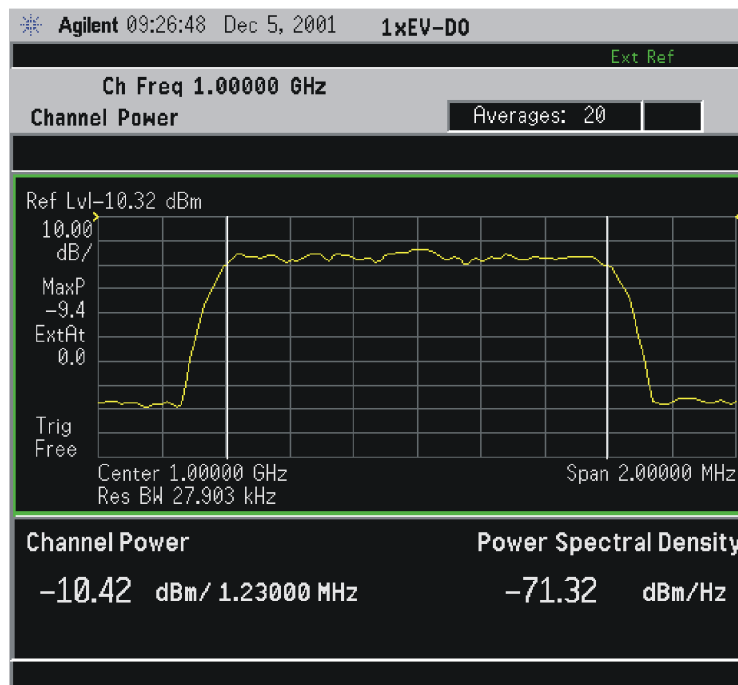

- Step 8.** Press the **Meas Setup, More (1 of 2)** keys to check the keys available to change the measurement parameters from the default condition.

If you have a problem, and get an error message, see [“If You Have a Problem”](#) on page 67.

Start Making Intermodulation Measurements

This section explains how to measure 1xEV-DO intermodulation products. The instrument, by default, measures the third- and fifth-order intermodulation products of the base frequency signal. Either two-tone or transmit intermodulation products are automatically identified.

Configuring the Measurement System

The access network (BTS) under test has to be set to transmit the RF power remotely through the system controller. The 1xEV-DO modulated interference signal is injected at the antenna output port of the BTS through an amplifier and circulator. The transmitting signal from the BTS is summed with the interferer and connected to the instrument's RF input port. Connect the equipment as shown below:

Figure 2-4

Intermodulation Products Measurement System

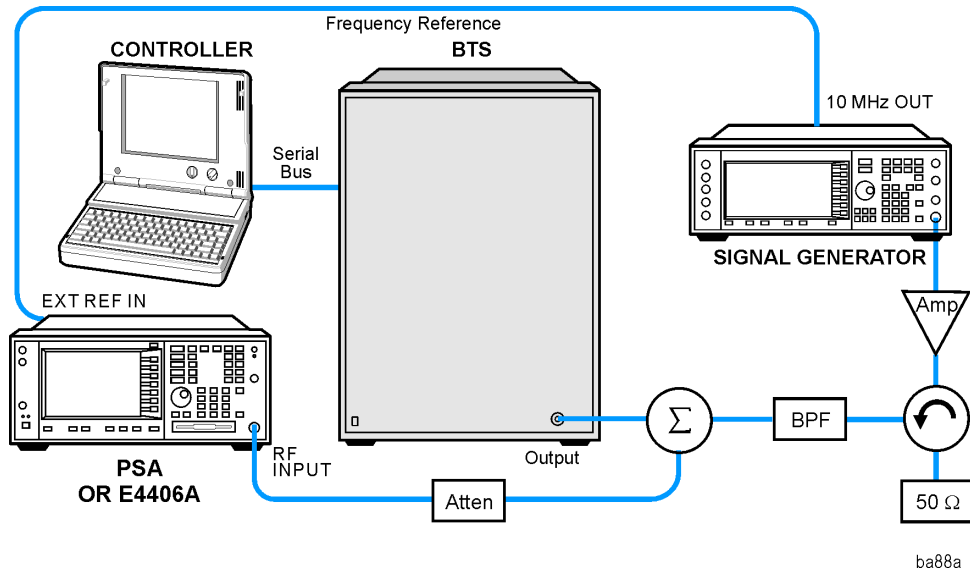

1. Using appropriate amplifier, circulators, etc., connect a 1xEV-DO carrier interference signal to the output connector of the BTS.
2. Connect the circulator output signal to the RF input port of the instrument through an attenuator.
3. Connect a BNC cable between the 10 MHz OUT port of the signal generator and the EXT REF IN port of the instrument.
4. Connect the system controller to the BTS with the serial bus cable.

Setting the BTS and Signal Generator

From the system controller, perform all of the functions required for the BTS to transmit the RF signal. Also set the signal generator to output the 3 MHz offset carrier signal to make an intermodulation measurement with the transmit IM and tone signals.

- **BTS** (transmit intermodulation signal)
 - Frequency: 1,935.000 MHz (preferred channel number 100)
(= $100 \times 0.050 + 1930.000$ MHz)
 - Output Power: Specified maximum output power level
- **Signal Generator** (interference carrier signal)
 - Frequency: 1,938.000 MHz (channel number 160)
 - Signal: CW (unmodulated carrier)
 - Output Power: Same level to the BTS output power at the BTS antenna output port

Measurement Procedure

- Step 1.** Press the **Preset** key to preset the instrument.
- Step 2.** Press the **MODE**, **1xEV-DO** keys to enable the 1xEV-DO measurements.
- Step 3.** Press the **Mode Setup**, **Input**, **Max Total Pwr** to enter the estimated maximum power from the BTS.
- Step 4.** Press the **Input Atten** and/or **Ext RF Atten** to enter the appropriate attenuation values depending on the estimated maximum power from the BTS.
- Step 5.** Press the **FREQUENCY Channel**, **1935**, **MHz** keys to set the center frequency to 1,935.000 MHz.
- Step 6.** Press the **MEASURE**, **Intermod** keys to initiate the intermodulation measurement.

The Intermodulation measurement result should look like the next figure. The intermodulation products are graphically displayed in the graph window. The absolute and relative power levels along with the lower and upper power spectral density levels are shown in the text

Getting Started
 Start Making Intermodulation Measurements

window.

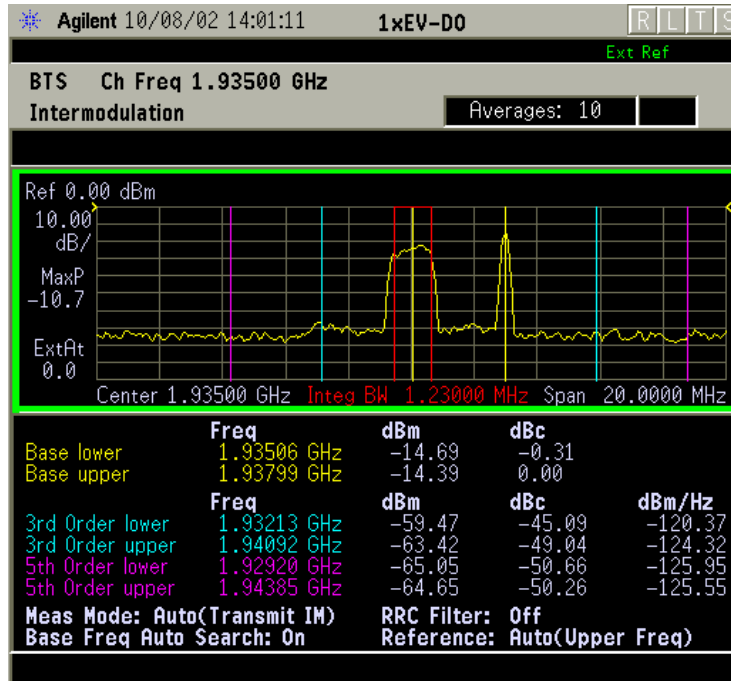

Step 7. Press the **Meas Setup, More (1 of 2)** keys to check the keys available to change the measurement parameters from the default condition.

If you have a problem, and get an error message, see [“If You Have a Problem”](#) on page 67.

Start Making Power versus Time Measurements

This section explains how to measure 1xEV-DO power versus time. The instrument, by default, measures the power versus time of the idle slot type.

Configuring the Measurement System

The access network (BTS) under test has to be set to transmit the RF power remotely through the system controller. The transmitting signal from the BTS is connected to the instrument's RF input port. Connect the equipment as shown below:

Figure 2-5

Power versus Time Measurement System

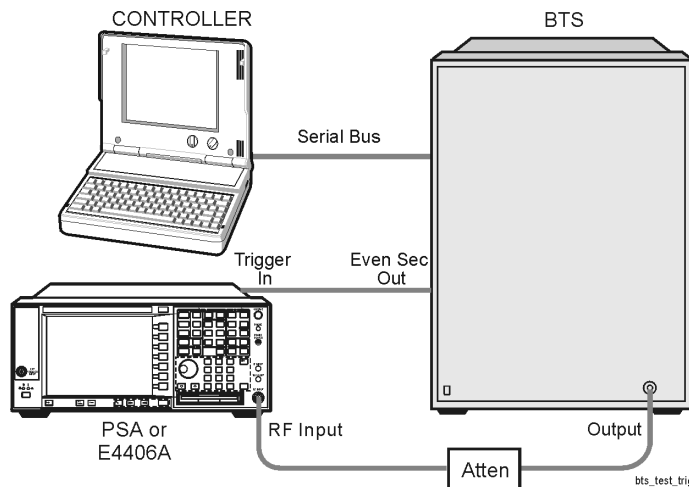

1. Connect the BTS output signal to the RF input port of the instrument through an attenuator.
2. Connect the system controller to the BTS with the serial bus cable.
3. Connect an appropriate cable assembly between the TRIGGER IN connector of the instrument and the Even Sec Out connector of the BTS for synchronization.

Setting the BTS

From the system controller, perform all of the functions required for the BTS to transmit the RF signal.

- BTS
Frequency: 1,935.000 MHz (preferred channel number 100)
(= $100 \times 0.050 + 1930.000$ MHz)

Output Power: Specified maximum output power level

Measurement Procedure

- Step 1.** Press the **Preset** key to preset the instrument.
- Step 2.** Press the **MODE, 1xEV-DO** keys to enable the 1xEV-DO measurements.
- Step 3.** Press the **Mode Setup, Input, Max Total Pwr** to enter the estimated maximum power from the BTS.
- Step 4.** Press the **Input Atten** and/or **Ext RF Atten** to enter the appropriate attenuation values depending on the estimated maximum power from the BTS.
- Step 5.** Press the **FREQUENCY Channel, 1935, MHz** keys to set the center frequency to 1,935.000 MHz.
- Step 6.** Press the **MEASURE, Power vs Time** keys to initiate the power versus time measurement.

The Power vs Time or RF Envelope measurement result should look like the next figure. The bust power and the region masks are graphically displayed in the graph window. The absolute power levels along with the maximum and minimum current data are shown in the text window.

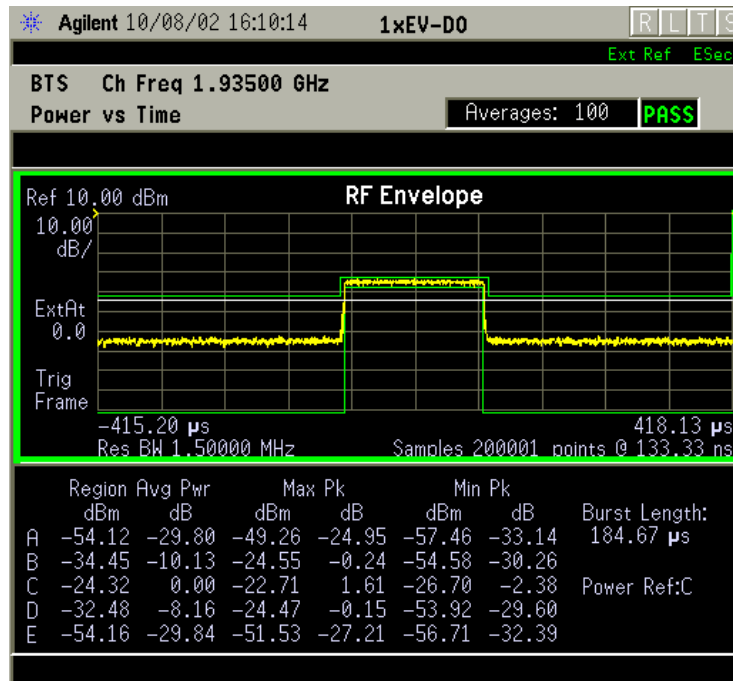

- Step 7.** Press the **View/Trace** and **Rise & Fall** keys to obtain the horizontally

expanded rising and falling edges as shown below:

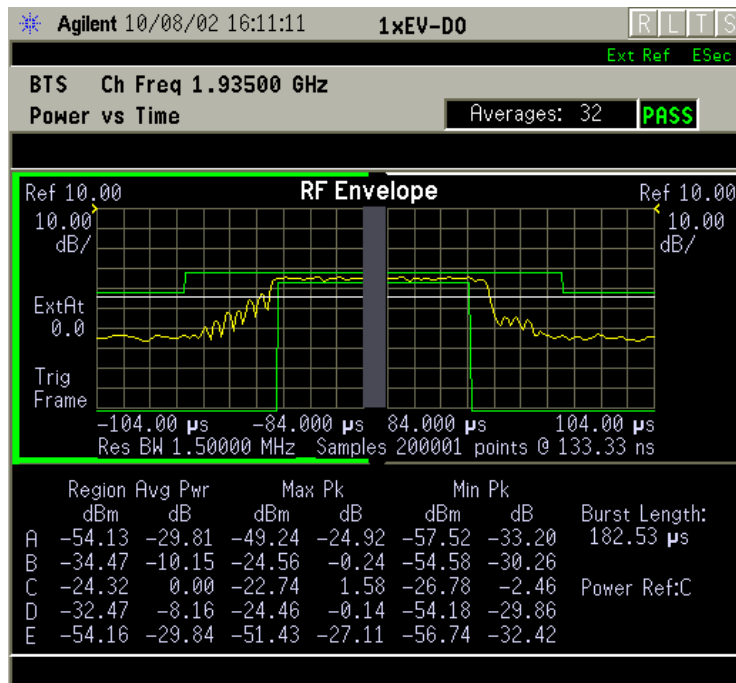

Step 8. Press the **Meas Setup, More (1 of 2)** keys to check the keys available to change the measurement parameters from the default condition.

If you have a problem, and get an error message, see [“If You Have a Problem”](#) on page 67.

Start Making Spurious Emissions & ACP Measurements

This section explains how to make a spurious emissions mask measurement (SEM) or adjacent channel power (ACP) measurement on a 1xEV-DO access network. ACP is a measurement of the amount of interference or power in an adjacent frequency channel. SEM compares the total power level within the defined carrier bandwidth and the given offset channels on both sides of the carrier frequency to levels allowed by the standard. Results of the measurement of each offset segment are viewable separately.

Configuring the Measurement System

The access network (BTS) under test has to be set to transmit the RF power remotely through the system controller. The transmitting signal from the BTS is connected to the instrument's RF input port. Connect the equipment as shown below:

Figure 2-6

Spurious Emissions & ACP Measurement System

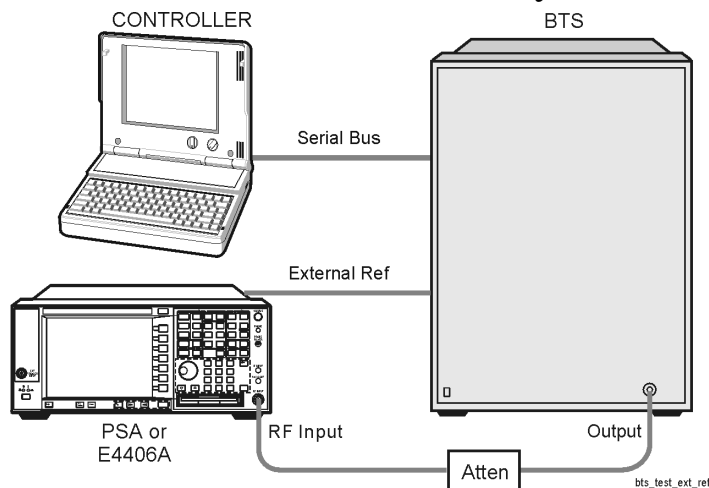

1. Using the appropriate cables and attenuators, connect the output signal from the BTS to the RF input port of the instrument.
2. Connect the reference signal from the BTS to the EXT REF IN connector of the tester.
3. Connect the system controller to the BTS through the serial bus cable to control the BTS operation.

Setting the BTS

From the system controller, perform all of the functions required for the BTS to transmit the RF signal.

- **BTS**
 Frequency: 1,935.000 MHz (preferred channel number 100)
 (= $100 \times 0.050 + 1930.000$ MHz)
 Output Power: Specified maximum output power level

Measurement Procedure

- Step 1.** Press the **Preset** key to preset the instrument.
- Step 2.** Press the **MODE, More (1 of 2), 1xEV-DO** keys to enable the 1xEV-DO measurements.
- Step 3.** Press the **Mode Setup, Input, Max Total Pwr** to enter the estimated maximum power from the BTS.
- Step 4.** Press the **Input Atten** and/or **Ext RF Atten** to enter the appropriate attenuation values depending on the estimated maximum power from the BTS.
- Step 5.** Press the **FREQUENCY Channel, 1935, MHz** keys to set the center frequency to 1,935.000 MHz.
- Step 6.** Press the **MEASURE, Spurious Emissions & ACP** keys to initiate the ACP or spurious emissions mask measurement.

The Spectrum Emission Mask: Spectrum (Ref: Total Pwr, Seg: Offset) result should look like the next figure. The graph window and a text window are displayed. The text window shows the reference total power and the absolute peak power levels which correspond to the frequency bands on both sides of the reference channel.

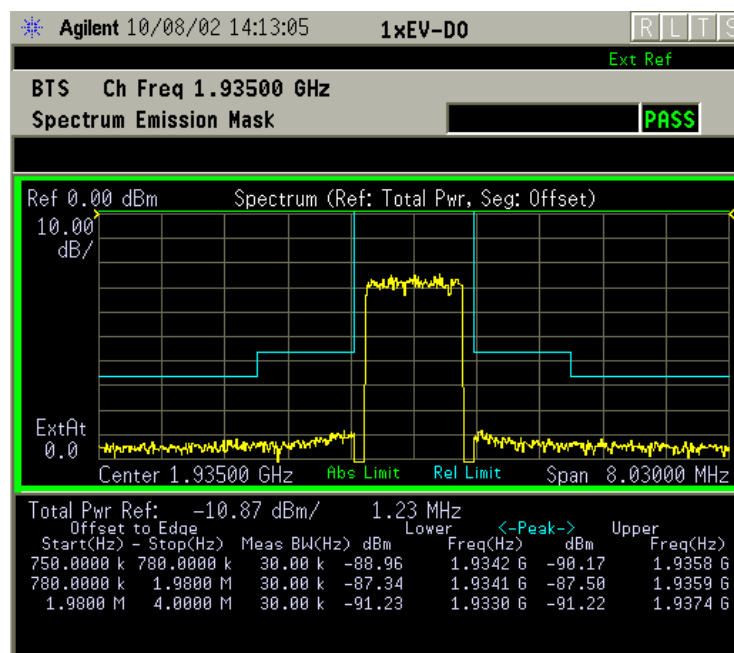

Step 7. Press the **Meas Setup**, **Spectrum Segment** keys to toggle to **Region**. The Spurious Emission: Spectrum (Ref: Total Pwr, Seg: Region) measurement result should look like the next figure.

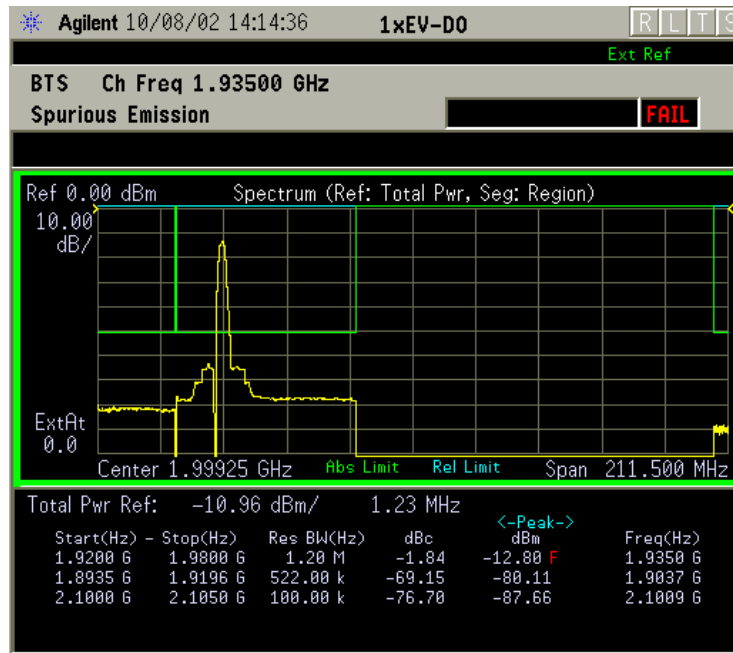

Step 8. Press the **Spectrum Segment** key back to **Offset**, and then press the **More (2 of 2)** and toggle the **Meas Mode** key to set to **ACP**.

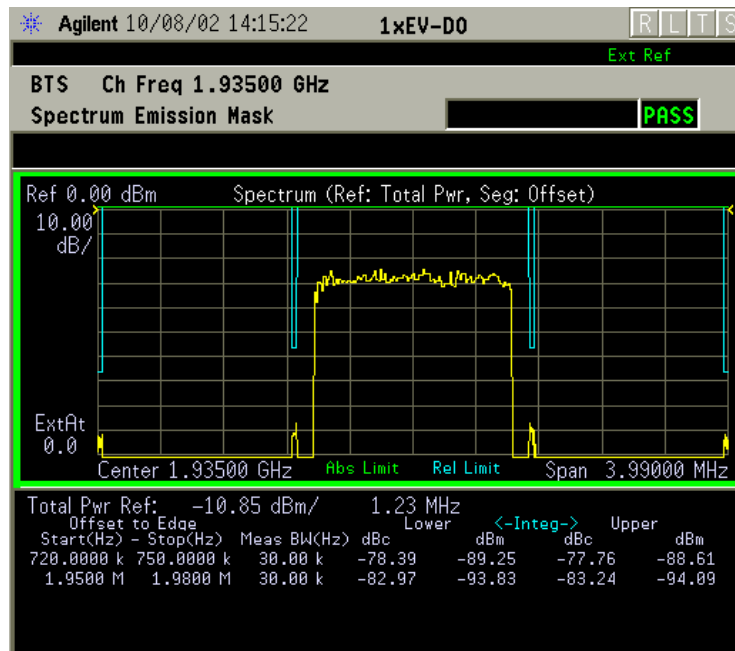

Step 9. Press the **Meas Setup**, **More (1 of 2)** keys to check the keys available to change the measurement parameters from the default condition.

If you have a problem, and get an error message, see [“If You Have a Problem”](#) on page 67.

Start Making Occupied Bandwidth Measurements

This section explains how to make an occupied bandwidth measurement on a 1xEV-DO base station. The tester measures power across the band, and then calculates its 99.0% power bandwidth.

Configuring the Measurement System

The access network (BTS) under test has to be set to transmit the RF power remotely through the system controller. This transmitting signal is connected to the instrument's RF input port. Connect the equipment as shown below:

Figure 2-7

Occupied Bandwidth Measurement System

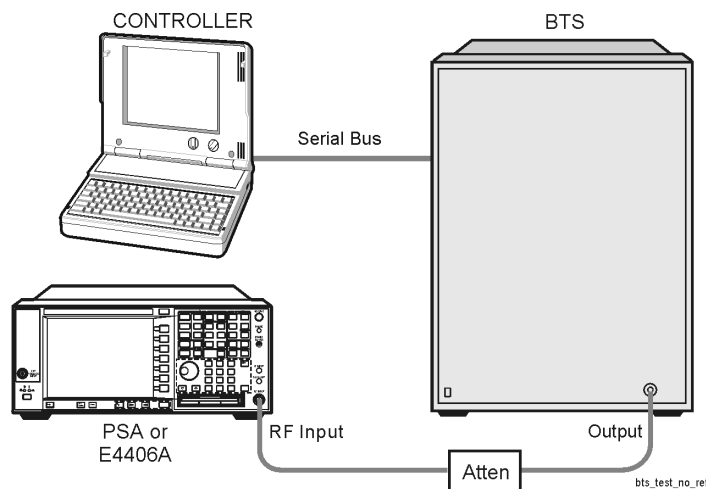

1. Using the appropriate cables and attenuators, connect the output signal from the BTS to the RF input port of the instrument.
2. Connect the system controller to the BTS through the serial bus cable to control the BTS operation.

Setting the BTS

From the system controller, perform all of the functions required for the BTS to transmit the RF signal.

- BTS
 - Frequency: 1,935.000 MHz (preferred channel number 100)
(= $100 \times 0.050 + 1930.000$ MHz)
 - Output Power: Specified maximum output power level

Measurement Procedure

- Step 1.** Press the **Preset** key to preset the instrument.
- Step 2.** Press the **MODE, More (1 of 2), 1xEV-DO** keys to enable the 1xEV-DO measurements.
- Step 3.** Press the **Mode Setup, Input, Max Total Pwr** to enter the estimated maximum power from the BTS.
- Step 4.** Press the **Input Atten** and/or **Ext RF Atten** to enter the appropriate attenuation values depending on the estimated maximum power from the BTS.
- Step 5.** Press the **FREQUENCY Channel, 1935, MHz** keys to set the center frequency to 1,935.000 MHz.
- Step 6.** Press the **MEASURE, Occupied BW** keys to initiate the occupied bandwidth measurement.

The Occupied BW measurement result should look like the next figure. A graph window with text showing the occupied bandwidth and the absolute total power level are displayed.

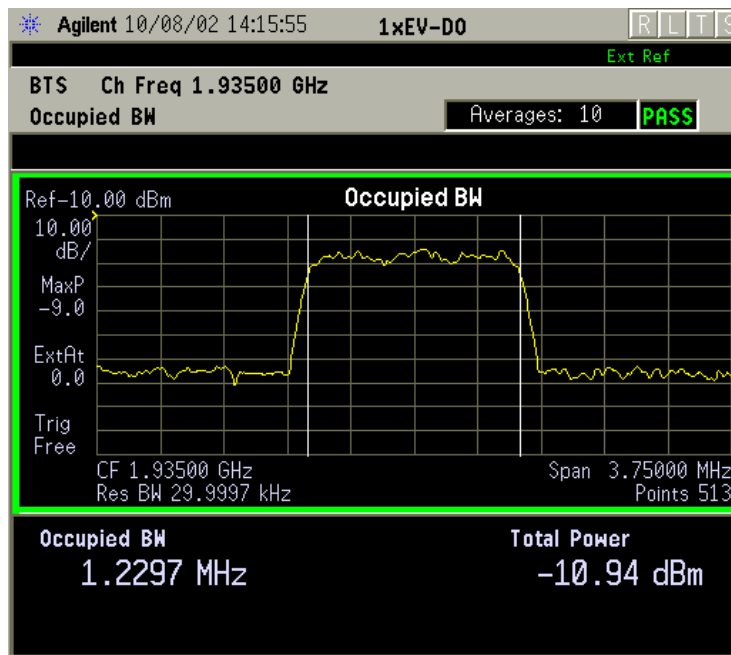

- Step 7.** Press the **Meas Setup, More (1 of 2)** keys to check the keys available to change the measurement parameters from the default condition.

If you have a problem, and get an error message, see [“If You Have a Problem”](#) on page 67.

Start Making Code Domain Measurements

This section explains how to make a code domain measurement on a 1xEV-DO base station. This is the measurement of the power levels of the spread channels in composite RF channels, relative to the total power within the 1.230 MHz channel bandwidth centered at the center frequency.

Configuring the Measurement System

The access network (BTS) under test has to be set to transmit the RF power remotely through the system controller. This transmitting signal is connected to the instrument's RF input port. Connect the equipment as shown below:

Figure 2-8

Code Domain Power Measurement System

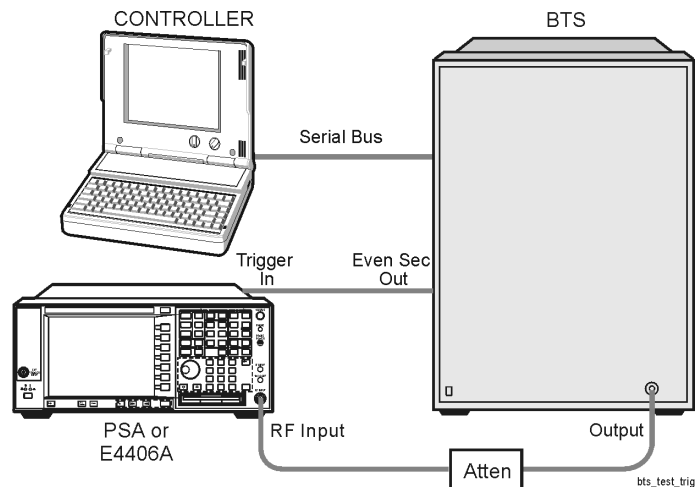

1. Using the appropriate cables and attenuators, connect the output signal from the BTS to the RF input port of the instrument.
2. Connect the system controller to the BTS through the serial bus cable to control the BTS operation.
3. Connect an appropriate cable assembly between the TRIGGER IN connector of the instrument and the Even Sec Out connector of the BTS for synchronization.

Setting the BTS

From the system controller, perform all of the functions required for the BTS to transmit the RF signal.

- BTS
 - Frequency: 1,935.000 MHz (preferred channel number 100)

$$(= 100 \times 0.050 + 1930.000 \text{ MHz})$$

Output Power: Specified maximum output power level

Measurement Procedure

- Step 1.** Press the **Preset** key to preset the instrument.
- Step 2.** Press the **MODE, More (1 of 2), 1xEV-DO** keys to enable the 1xEV-DO measurements.
- Step 3.** Press the **Mode Setup, Input, Max Total Pwr** to enter the estimated maximum power from the BTS.
- Step 4.** Press the **Input Atten** and/or **Ext RF Atten** to enter the appropriate attenuation values depending on the estimated maximum power from the BTS.
- Step 5.** Press the **FREQUENCY Channel, 1935, MHz** keys to set the center frequency to 1,935.000 MHz.
- Step 6.** Press the **MEASURE, More (1 of 2), Code Domain** keys to initiate the code domain measurement. The Code Domain: Power measurement result should look like the next figure. The graph window and the text window are displayed for the pilot channel. The text window shows the total power level along with the relative power levels of the various channels.

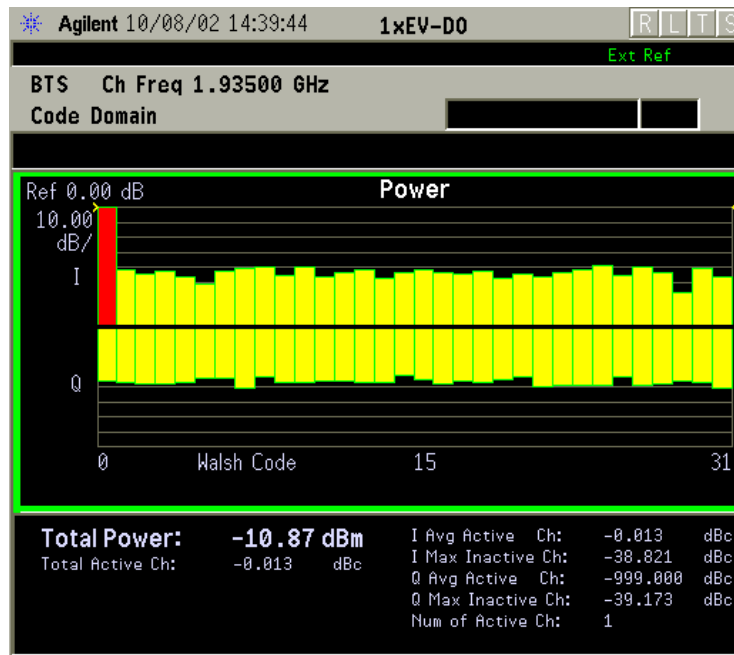

- Step 7.** Press the **View/Trace, I/Q Polar & Power Graph** keys to display a combination view of the code domain power, I/Q symbol polar vector, and selected chip power graph windows for the pilot channel as shown

below:

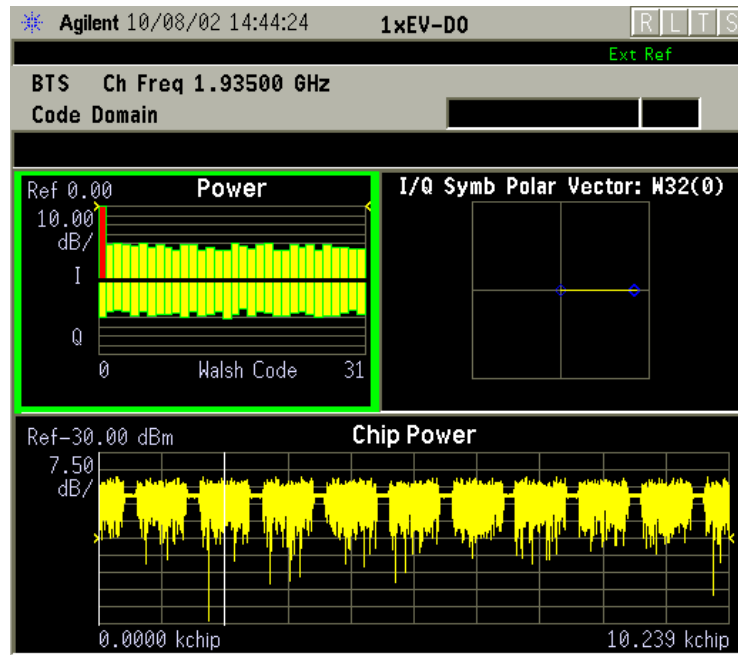

Step 8. Press the **Meas Control** key to change the **Measure** key from **Single** to **Cont**. The measurement and displayed data will be made repeatedly.

Step 9. Press the **Meas Setup**, **More (1 of 3)**, **More (2 of 3)** keys to check the keys available to change the measurement parameters from the default condition.

If you have a problem, and get an error message, see [“If You Have a Problem”](#) on page 67.

Start Making Modulation Accuracy (Composite Rho) Measurements

This section explains how to make a modulation accuracy (composite Rho) measurement on a 1xEV-DO base station. Rho is the ratio of the correlated power in a multi coded channel to the total signal power.

Configuring the Measurement System

The access network (BTS) under test has to be set to transmit the RF power remotely through the system controller. This transmitting signal is connected to the instrument's RF input port. Connect the equipment as shown below:

Figure 2-9

Modulation Accuracy Measurement System

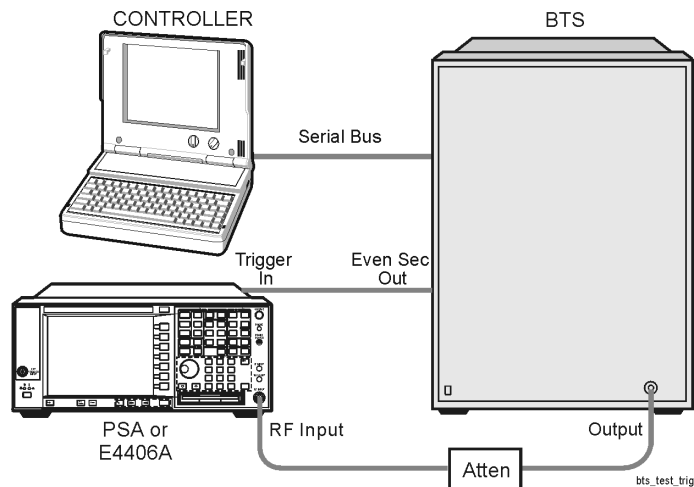

1. Using the appropriate cables and attenuators, connect the output signal from the BTS to the RF input port of the instrument.
2. Connect the system controller to the BTS through the serial bus cable to control the BTS operation.
3. Connect an appropriate cable assembly between the TRIGGER IN connector of the instrument and the Even Sec Out connector of the BTS for synchronization.

Setting the BTS

From the system controller, perform all of the functions required for the BTS to transmit the RF signal.

- BTS
Frequency: 1,935.000 MHz (preferred channel number 100)
(= $100 \times 0.050 + 1930.000$ MHz)

Output Power: Specified maximum output power level

Measurement Procedure

- Step 1.** Press the **Preset** key to preset the instrument.
- Step 2.** Press the **MODE, More (1 of 2), 1xEV-DO** keys to enable the 1xEV-DO measurements.
- Step 3.** Press the **Mode Setup, Input, Max Total Pwr** to enter the estimated maximum power from the BTS.
- Step 4.** Press the **Input Atten** and/or **Ext RF Atten** to enter the appropriate attenuation values depending on the estimated maximum power from the BTS.
- Step 5.** Press the **FREQUENCY Channel, 1935, MHz** keys to set the center frequency to 1,935.000 MHz.
- Step 6.** Press the **MEASURE, More (1 of 2), Mod Accuracy (Composite Rho)** keys to initiate the measurement.

The Mod Accuracy: I/Q Measured Polar Vector measurement result should look like the next figure. The measurement values for modulation accuracy are shown in the summary result window.



- Step 7.** Press the **View/Trace, I/Q Error (Quad View)** keys to display a combination view of the magnitude error, phase error, EVM graph windows, and the

modulation summary result window.

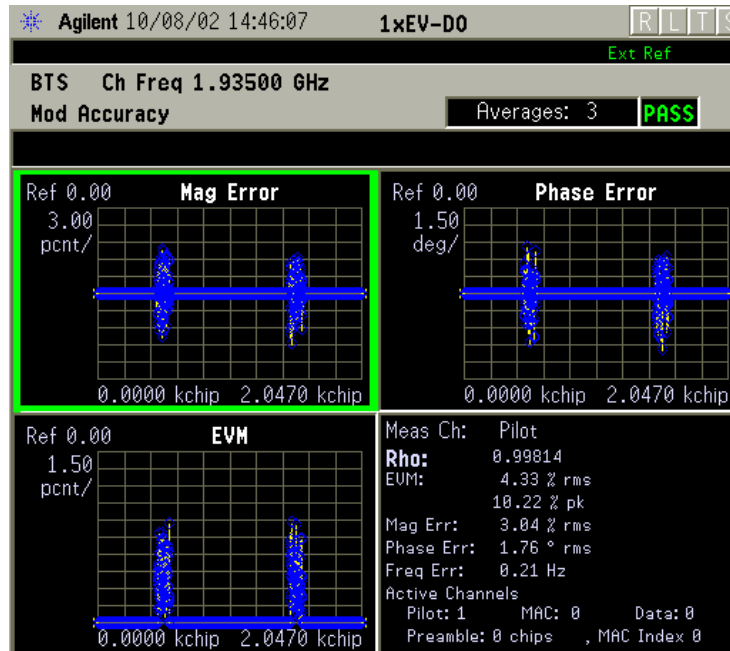

Step 8. Press the **View/Trace, I/Q Measured (Quad View)** keys to display a combination view of the I/Q waveform, chip power, polar vector graph windows, and the mean power result window.

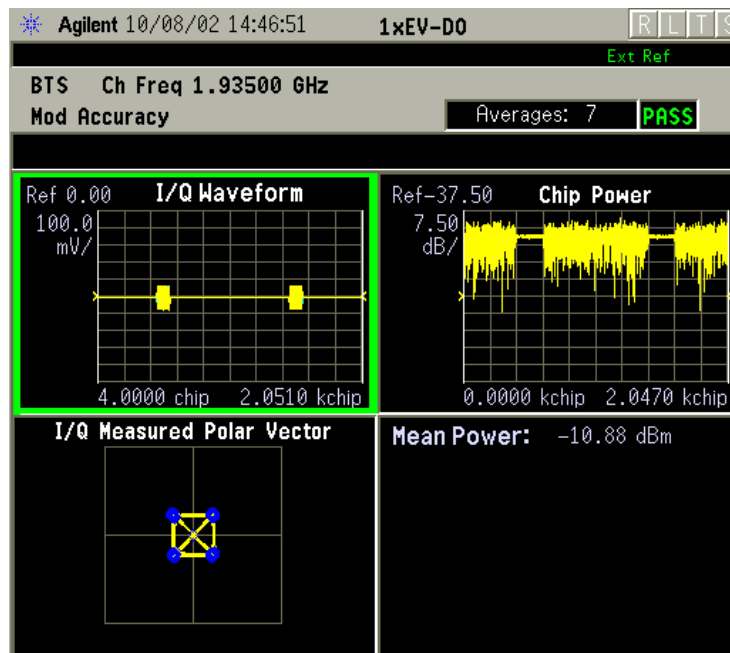

Step 9. Press the **Result Metrics** and **Power Timing & Phase** keys to observe the measured results in the text windows. To make this observation, you may need to press the **Rho/EVM Channel Type** key to change to **Data**, and

the **Multi Channel Estimator** (under the **Advanced** menu) key to turn on.

The top screenshot shows the following data:

```

Agilent 10/08/02 14:45:22    1xEV-DO    R L T S
Ext Ref
BTS Ch Freq 1.93500 GHz
Mod Accuracy    Averages: 8    PASS
  
```

Result Metrics

```

Measured Ch: Pilot
Rho:          0.99809
EVM:          4.39 % rms
              10.76 % pk
Magnitude Error: 3.07 % rms
Phase Error:   1.79 ° rms
Frequency Error: 0.09 Hz
I/Q Origin Offset: -37.46 dB
Pilot Offset:  ---
Active Channels Pilot: 1   MAC: ---   Data: ---
  
```

The bottom screenshot shows the following data:

```

Agilent 10/08/02 15:12:52    1xEV-DO    R L T S
Ext Ref
BTS Ch Freq 1.93500 GHz
Mod Accuracy    Averages: 1    FAIL
  
```

Code	Power(dB)	Timing(ns)	Phase(rad)
C4(0)	-14.96	Reference	Reference
C4(1)	-15.12	1.32	-0.041
C4(2)	-15.10	8.74	-0.037
C4(3)	-15.32	30.77	-0.020
C4(4)	-15.08	16.25	0.048
C4(5)	-15.21	21.54	-0.024
C4(6)	-14.90	20.54	-0.044
C4(7)	-15.15	55.95F	0.048
C4(8)	-15.15	68.01F	-0.100F
C4(9)	-14.89	13.24	-0.049
C4(10)	-14.94	32.34	-0.032
C4(11)	-15.08	-29.48	-0.024
C4(12)	-14.95	16.01	0.009
C4(13)	-14.99	-5.73	-0.035
C4(14)	-14.93	2.43	-0.018
C4(15)	-14.96	48.88	-0.006

Step 10. Press the **Meas Setup, More (1 of 2)** keys to check the keys available to change the measurement parameters from the default condition.

If you have a problem, and get an error message, see [“If You Have a Problem”](#) on page 67.

Start Making QPSK EVM Measurements

This section explains how to make a quadrature phase shift keying (QPSK) error vector magnitude (EVM) measurement on a 1xEV-DO base station. QPSK EVM is a measure of phase and amplitude modulation quality that relates the performance of the actual signal compared to an ideal signal as a percentage, as calculated over the course of the ideal constellation.

Configuring the Measurement System

The access network (BTS) under test has to be set to transmit the RF power remotely through the system controller. This transmitting signal is connected to the instrument's RF input port. Connect the equipment as shown below:

Figure 2-10

QPSK EVM Measurement System

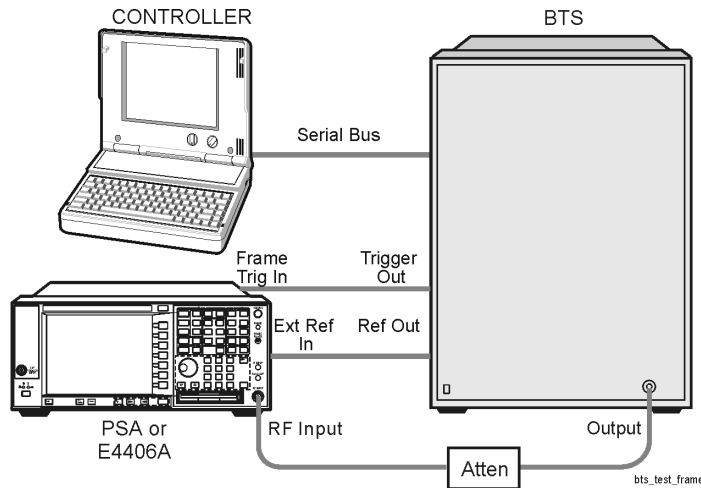

1. Using the appropriate cables and attenuators, connect the output signal from the BTS to the RF input port of the instrument.
2. Connect the system controller to the BTS through the serial bus cable to control the BTS operation.
3. Connect an appropriate cable assembly between the FRAME TRIG IN connector of the instrument and the trigger output connector of the BTS.
4. Connect an appropriate cable assembly between the EXT REF IN connector of the instrument and the reference output connector of the BTS.

Setting the BTS

From the system controller, perform all of the functions required for the

BTS to transmit the RF signal.

- **BTS**
 - Frequency: 1,935.000 MHz (preferred channel number 100)
(= $100 \times 0.050 + 1930.000$ MHz)
 - Output Power: Specified maximum output power level

Measurement Procedure

- Step 1.** Press the **Preset** key to preset the instrument.
- Step 2.** Press the **MODE, More (1 of 2), 1xEV-DO** keys to enable the 1xEV-DO measurements.
- Step 3.** Press the **Mode Setup, Input, Max Total Pwr** to enter the estimated maximum power from the BTS.
- Step 4.** Press the **Input Atten** and/or **Ext RF Atten** to enter the appropriate attenuation values depending on the estimated maximum power from the BTS.
- Step 5.** Press the **FREQUENCY Channel, 1935, MHz** keys to set the center frequency to 1,935.000 MHz.
- Step 6.** Press the **MEASURE, More (1 of 2), QPSK EVM** keys to set the instrument to initiate the QPSK EVM measurement.

The QPSK EVM: I/Q Measured Polar Vector measurement result should look like the next figure. The measurement values for modulation accuracy are shown in the summary result window.

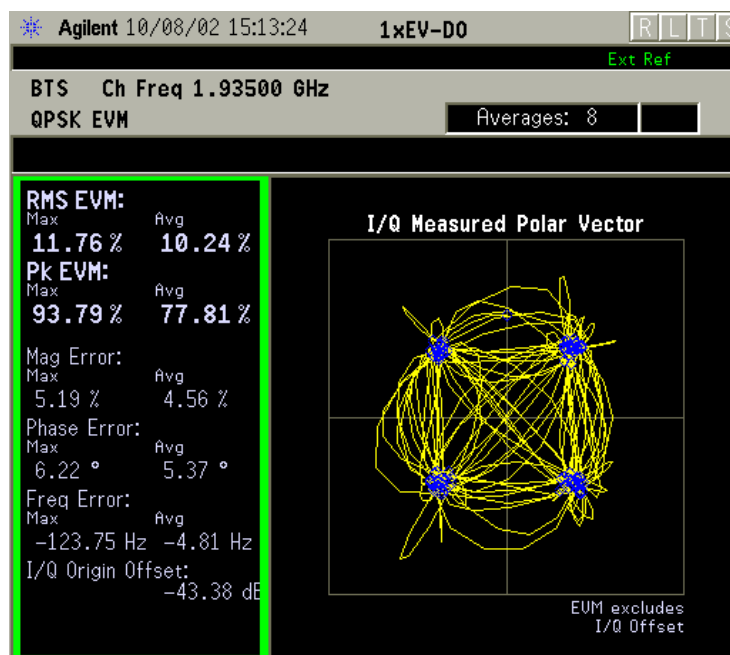

- Step 7.** Press the **View/Trace, I/Q Measured Polar Constln** keys to display a

combination view of the I/Q measured polar constellation graph window and the modulation summary result window.

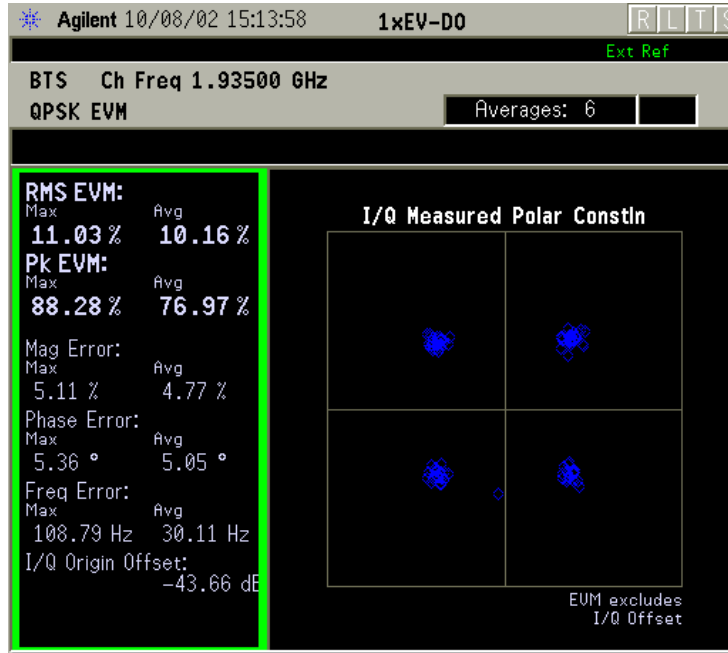

Step 8. Press the **View/Trace, I/Q Error (Quad View)** keys to display a combination view of the magnitude error, phase error, and EVM graph windows, and the modulation summary result window.

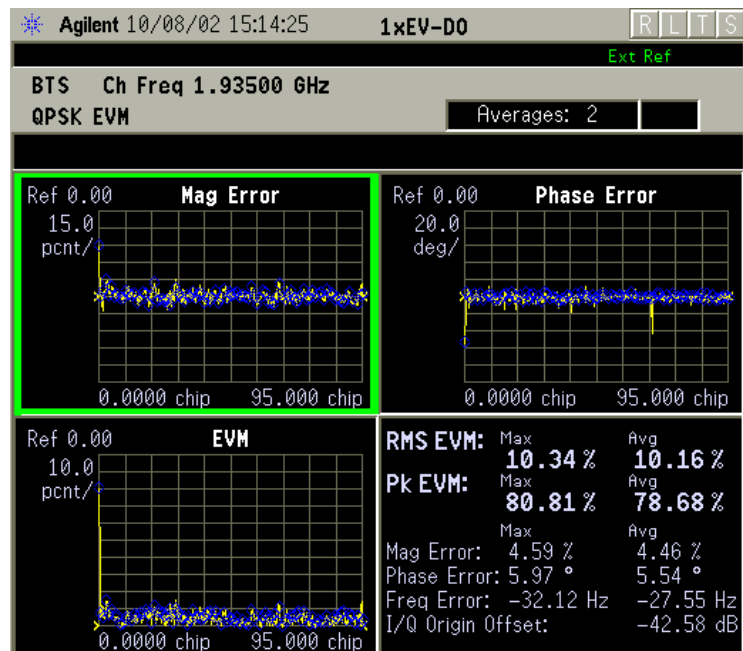

Step 9. Press the **Meas Setup, More (1 of 2)** keys to check the keys available to change the measurement parameters from the default condition.

If you have a problem, and get an error message, see [“If You Have a Problem”](#) on page 67.

Start Making Power Stat CCDF Measurements

This section explains how to make a power statistics CCDF measurement on a 1xEV-DO base station. Power Complementary Cumulative Distribution Function (CCDF) curves characterize the higher level power statistics of a digitally modulated signal.

Configuring the Measurement System

The access network (BTS) under test has to be set to transmit the RF power remotely through the system controller. This transmitting signal is connected to the instrument's RF input port. Connect the equipment as shown below:

Figure 2-11

Power Statistics (CCDF) Measurement System

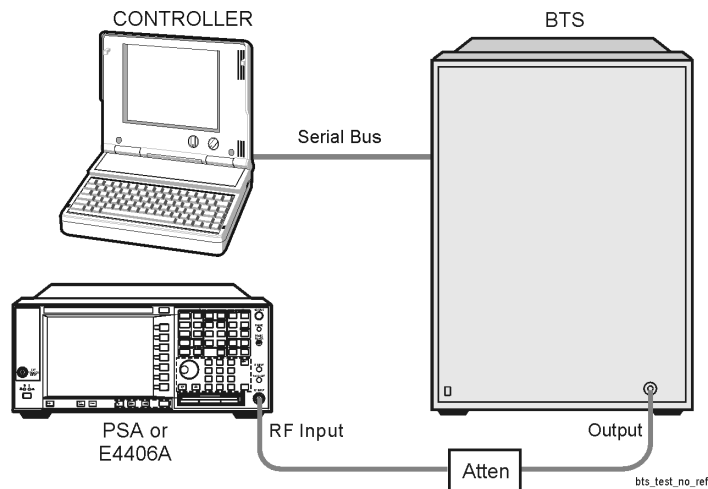

1. Using the appropriate cables and attenuators, connect the output signal from the BTS to the RF input port of the instrument.
2. Connect the system controller to the BTS through the serial bus cable to control the BTS operation.

Setting the BTS

From the system controller, perform all of the functions required for the BTS to transmit the RF signal.

- BTS
 - Frequency: 1,935.000 MHz (preferred channel number 100)
(= $100 \times 0.050 + 1930.000$ MHz)
 - Output Power: Specified maximum output power level

Measurement Procedure

- Step 1.** Press the **Preset** key to preset the instrument.
- Step 2.** Press the **MODE, More (1 of 2), 1xEV-DO** keys to enable the 1xEV-DO measurements.
- Step 3.** Press the **Mode Setup, Input, Max Total Pwr** to enter the estimated maximum power from the BTS.
- Step 4.** Press the **Input Atten** and/or **Ext RF Atten** to enter the appropriate attenuation values depending on the estimated maximum power from the BTS.
- Step 5.** Press the **FREQUENCY Channel, 1935, MHz** keys to set the center frequency to 1,935.000 MHz.
- Step 6.** Press the **MEASURE, More (1 of 2), Power Stat CCDF** keys to initiate the power statistics CCDF measurement.

The CCDF measurement result should look like the next figure. The measurement result values are shown in the summary result window.

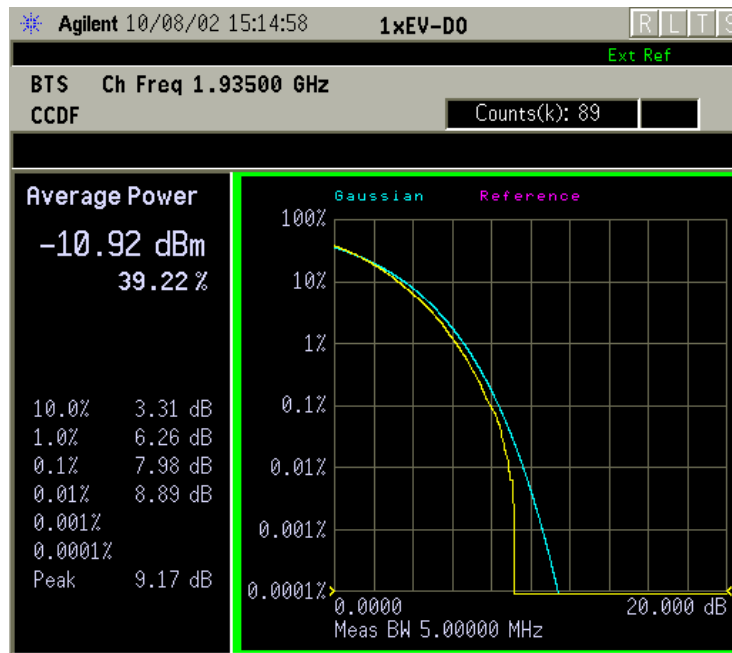

- Step 7.** Press the **Meas Setup, More (1 of 2)** keys to check the keys available to change the measurement parameters from the default condition.

If you have a problem, and get an error message, see [“If You Have a Problem”](#) on page 67.

If You Have a Problem

During the execution of your measurement you may encounter problems which generate error codes. Reference to the following common errors may be helpful.

If **Err** is shown in the annunciator bar, press the **System**, **Show Errors** hard and soft keys to read the detailed error information.

- **Measurement Instability- Low Input Signal Level**

If the input signal level is too low to make a valid measurement no code domain power will be displayed in the **Power** graph window. In this situation, no error message can be displayed to indicate the nature of the fault. If you cannot increase the power into the tester, you need to increase the input sensitivity by adjusting the **ADC** range.

Press the **Meas Setup**, **More (1 of 3)**, **More (2 of 3)**, **Advanced**, **ADC Range**, **Manual** keys. Increase the setting from the **None** default to 6 dB, for example. Another option is to use the **AUTO** setting (the **AUTO** setting is not used as the default to improve measurement speed).

Press **Restart** to make another measurement and observe the results. Re-adjust the **ADC** as necessary to obtain a valid measurement.

- **Error Code 16 “Input overload”**

This error means that your measurement has erroneous results due to the excessive input power level. To correct this condition, the input signal level must be reduced by using the internal and/or external attenuators.

Press the **Mode Setup**, **Input**, **Input Atten** keys to enter an attenuation value to reduce the transmitted power from the **BTS**. This allowable range is up to 40 dB.

If you want to attenuate more than 40 dB, connect your external attenuator between the **RF INPUT** port and the **DUT**. Be sure to add its attenuation value to the readings of the measurement result.

To automate this calculation, press the **Mode Setup**, **Input**, **Ext Atten** keys to enter the additional attenuation value. The allowable range is up to 100 dB. The power readings of the measurement will take into account the external attenuation value.

- **Error Code 601 “Signal too noisy”**

This error means that your input signal is too noisy to capture the correct **I/Q** components. To make a more stable measurement the trigger source may need to be set to **Frame**, for example.

- **Error Code 604 “Can not correlate to input signal”**

This error means that the tester has failed to find any active channels in the input signal as specified. To improve the correlation some critical parameter needs to be adjusted, like the input signal level or scramble code, for example.

For more details consult the chapter in this book dedicated to the measurement in question, or “Instrument Messages and Functional Tests”, publication number E4406-90184.

3 Setting Up the Mode

1xEV-DO Mode

Instructions for installing and uninstalling personality options are under “[Installing Optional Measurement Personalities](#)” on page 114.

To access the 1xEV-DO measurement personality, press the **MODE** key and select the **1xEV-DO** key.

If you want to set the 1xEV-DO mode to a known, factory default state, press **Preset**. This will preset the mode setup and all of the measurements to the factory default parameters.

NOTE

Pressing the **Preset** key does not switch instrument modes if the Mode type of preset is selected under **System, Power On/Preset**.

Making a Measurement

This instrument enables you to make a wide variety of measurements on digital communications equipment using the **Basic Mode** (for E4406A), or the **Spectrum Analysis Mode** (for PSA) measurement capabilities. It also has optional measurement personalities that make measurements based on established industry standards.

To set up the instrument to make measurements, you need to:

1. Press **MODE** to select a personality which corresponds to a digital communications format, like cdma2000, W-CDMA, or EDGE. Or use the **Basic mode** to make measurements on signals with non-standard formats. After selecting the mode, make any required adjustments to the mode settings by pressing **Mode Setup**.
2. Press **MEASURE** to select a specific measurement to be performed, like ACP, Channel Power, or EVM, and so forth. After selection of your measurement, make any required adjustments to the measurement settings by pressing **Meas Setup**.

Depending on the current settings of **Meas Control**, the instrument will begin making the selected measurements. The resulting data will be shown on the display or available for export.

3. Press **Trace/View** to display the data from the current measurement. Depending on the mode and measurement selected, various graphical and tabular presentations are available.

If you have a problem, and get an error message, see the “If You Have a Problem” section in each measurement description.

The main keys used in the three steps are shown in the table below.

Step	Primary Key	Setup Keys	Related Keys
1. Select & setup a mode	MODE	Mode Setup, Input (E4406A), Input/Output (PSA), FREQUENCY Channel	System
2. Select & setup a measurement	MEASURE	Meas Setup	Meas Control, Restart
3. Select & setup a view	View/Trace (E4406A), Trace/View (PSA)	SPAN X Scale, AMPLITUDE Y Scale, Display, Next Window, Zoom	File, Save, Print, Print Setup, Marker, Search (E4406A), Peak Search (PSA)

A setting may be reset at any time, and will be in effect on the next measurement cycle or View.

Changing the Mode Setup

Numerous settings can be changed at the mode level by pressing the **Mode Setup** key. This will access the menu with the selections listed below. The factory default settings are shown in tables. These settings affect only the measurements in the 1xEV-DO mode.

Configuring the Radio Setting

The **Radio** key reveals the **Device** menu to select either **BTS (Fwd)** (for forward link tests) or **MS (Rev)** (for reverse link tests).

- **Device** - Allows you to access the menu to select a test station as follows:
 - **BTS (Fwd)** - Sets to make forward link tests or access network (base station transceiver system) tests. This is the default selection for all of the measurement functions.
 - **MS (Rev)** - Sets to make reverse link tests or access terminal (mobile station) tests. This will be always selectable, however, there can be some limitations of measurement selections as follows:

Depending on the selection of measurements, there will be the following differences in forward link tests and reverse link tests:

- ❑ *Dedicated to Forward Link* - The measurement functions for **Intermod, Power vs Time, Spurious Emissions & ACP, and QPSK EVM** are available when **Device** under **Radio** is set to **BTS (Fwd)**, otherwise these measurement keys are grayed out.
- ❑ *Common for Both Links* - The measurement functions for **Channel Power, Occupied BW, Power Stat CCDF, Spectrum (Freq**

Domain), and **Waveform (Time Domain)** are available for both **BTS (Fwd)** and **MS (Rev)** selections under **Device**.

- ❑ *Unique to Forward Link or to Reverse Link* - The measurement functions for **Code Domain** and **Mod Accuracy (Composite Rho)** are designed uniquely to BTS tests or to MS tests. The measurement menus, measurement items, and screen pictures are different from each other depending on the selection of **BTS (Fwd)** or **MS (Rev)** under **Device**. For BTS tests, refer to “[Making the Forward Link Code Domain Measurement](#)” on page 170 and “[Making the Forward Link Modulation Accuracy \(Composite Rho\) Measurement](#)” on page 197. For MS tests, refer to “[Making the Reverse Link Code Domain Measurement](#)” on page 181 and “[Making the Reverse Link Modulation Accuracy \(Composite Rho\) Measurement](#)” on page 214.

Configuring the Input Condition

The **Input** key accesses the menu as follows: (You can also access this menu from the **Input** front-panel key.)

- **Input Port** - Allows you to access the menu to select one of the signal input ports as follows:
 - **RF** - Allows you to measure an RF signal supplied to the RF input port.
 - **50 MHz Ref** - Allows you to measure the internal 50 MHz reference signal to calibrate the instrument of VSA.
 - **Amptd Ref (f=50 MHz)** - Allows you to measure the internal 50 MHz reference signal to calibrate the instrument of PSA.
 - **IF Align** - Allows you to configure the IF alignment signal. The RF path is switched to bring in the same alignment signal that is automatically switched to perform many alignments.
- **RF Input Range** - Allows you to toggle the RF input range control between **Auto** and **Man** (manual). If **Auto** is chosen, the instrument automatically sets the attenuator based on the carrier power level, where it is tuned. Once you change the **Max Total Pwr** or **RF Input Atten** value with the RPG knob, for example, the **RF Input Range** key is automatically set to **Man**. If there are multiple carriers present, the total power might overdrive the front end. In this case you need to set the **RF Input Range** to **Man** and enter the expected maximum total power by activating the **Max Total Pwr** key. **Man** is also useful to hold the input attenuation constant for the best relative power accuracy. For single carriers it is generally recommended to set this to **Auto**.

When you use the internal preamplifier, **Int Preamp**, on PSA with Option 1DS, the selections using the **RF Input Range** key are not available, and the key is grayed out.

- **Max Total Pwr** - Allows you to set the maximum total power level from the UUT (Unit Under Test). The range is -200.00 to 100.00 dBm with 0.01 dB resolution. This is the expected maximum value of the mean carrier power referenced to the output of the UUT; it may include multiple carriers. The **Max Total Pwr** setting is coupled together with the **Input Atten** and **Ext Atten** settings. Once you change the **Max Total Pwr** value with the RPG knob, for example, the **Input Range** key is automatically set to **Man**.

When you use the internal preamplifier, **Int Preamp**, on PSA with Option 1DS, the selections using the **Max Total Pwr** key are not available, and the key is grayed out.

- **Input Atten** - Allows you to control the internal input attenuator setting. The range is 0 to 40 dB with 1 dB resolution. The **Input Atten** key reads out the actual hardware value that is used for the current measurement. If more than one input attenuator value is used in a single measurement, the value used at the carrier frequency will be displayed. The **Input Atten** setting is coupled to the **Max Total Pwr** setting. Once you change the **Input Atten** setting with the RPG knob, for example, the **Input Range** key is automatically set to **Man**.

When you use the internal preamplifier, **Int Preamp**, on PSA with Option 1DS, the electronic attenuator selections using the **Input Atten** key are not available, and the key is greyed-out. Use the mechanical attenuator under **More 1 of 2, Attenuator**, below.

- **Ext RF Atten** - Allows you to access the following menu to enter the external attenuation values. Either of the **Ext RF Atten** settings is coupled together with the **RF Input Range** setting. However, pressing **Ext RF Atten** does not switch the **RF Input Range** key to **Man**. This will allow the instrument to display the measurement results referenced to the output of the UUT.
 - **MS** - Allows you to set an external attenuation value for MS tests. The range is -50.00 to $+50.00$ dB with 0.01 dB resolution.
 - **BTS** - Allows you to set an external attenuation value for BTS tests. The range is -50.00 to $+50.00$ dB with 0.01 dB resolution.
- **Int Preamp** - (for PSA with Option 1DS) Allows you to control the internal RF input preamplifier. The internal preamplifier provides $+30$ dB of gain and is useful for lower power measurements. The **Int Preamp** setting default is **Off**. RF power values displayed for these measurements are adjusted to compensate for the internal preamplifier gain, and indicate power levels at the input port. The preamplifier is only available for Modulation Accuracy (EVM and Peak Code Domain Error) measurements, QPSK EVM, and Code Domain measurements. If the **Int Preamp** is not available for a particular measurement, the key is greyed-out.

To avoid damaging the internal preamplifier, limit the total power applied to the RF input to $\leq +25$ dBm.

Setting Up the Mode

1xEV-DO Mode

When using the internal preamplifier, the electronic attenuator selections using the **Input Atten** key are not available, and the key is greyed-out. Use the mechanical attenuator under **More 1 of 2, Attenuator**, below.

- **Attenuator** - (for PSA with Option 1DS) When **Int Preamp** is set to **On**, this key allows you to control an internal mechanical input attenuator setting. The settings available are 0 dB, 10 dB, or 20 dB. The **Attenuator** key shows the actual hardware value that is used for the current measurement. The **Attenuator** setting is not coupled to the **Max Total Pwr** setting.

The **Attenuator** is only available for measurements which can use the **Int Preamp**: Modulation Accuracy, QPSK EVM, and Code Domain measurements. If the **Int Preamp** is not available for a particular measurement, the key is greyed-out.

NOTE

The **Max Total Pwr** and **Input Atten** settings are coupled together, so changing the input **Max Total Pwr** setting by x dB changes the **Input Atten** setting by x dB. When you switch to a different measurement, the **Max Total Pwr** setting is kept constant, but the **Input Atten** may change if the two measurements have different mixer margins. Therefore, you can set the input attenuator manually, or you can set it indirectly by specifying the expected maximum power from the UUT.

Input Default Settings	
Input Port	RF
RF Input Range	Auto ^a
Max Total Pwr	-15.00 dBm ^b
Input Atten	0.00 dB ^b
Ext RF Atten:	
MS	0.00 dB
BTS	0.00 dB
Int Preamp ^c (PSA Option 1DS)	OFF
Attenuator ^c (PSA Option 1DS)	0 dB

a. Auto is not used for Spectrum (frequency domain) measurements.

b. This may differ if the maximum input power is more than -15.00 dBm, or depending on the previous measurements.

c. The internal preamplifier and attenuator are available for Modulation Accuracy (EVM and Peak Code Domain Error), QPSK EVM, and Code Domain measurements on PSA with Option 1DS.

Configuring the Trigger

The **Trigger** key allows you:

- (1) to access the trigger selection menu to specify each triggering condition,
- (2) to modify the default trigger holdoff time using the **Trig Holdoff** key,
- (3) to modify the auto trigger time and to activate or deactivate the auto trigger feature using the **Auto Trig** key, and
- (4) to modify the period of the frame timer using the **Frame Timer** key.

NOTE

The actual trigger source is selected individually for each measurement under the **Meas Setup** key.

- **RF Burst, Video (Envlp), Ext Front, Ext Rear**- Pressing one of these trigger keys will access each triggering condition setup menu. This menu is used to specify the **Delay**, **Level** and **Slope** settings for each trigger source as follows:
 - **Delay** - Allows you to enter a numerical value to modify the trigger delay time. The range is -100.0 to $+500.0$ ms with $1\ \mu\text{s}$ resolution. For trigger delay use a positive value, and for pre-trigger use a negative value.
 - **Level** - Allows you to enter a numerical value to adjust the trigger level depending on the trigger source selected.
 - For **RF Burst**, the key label reads as **Peak Level**. The RF level range is -25.00 to 0.00 dB with 0.01 dB resolution, relative to the peak RF signal level. The realistic range can be down to -20 dB.
 - For **Video (Envlp)**, the video level range is -200.00 to $+50.00$ dBm with 0.01 dB resolution at the RF input. The realistic range can be down to around -50 dBm depending on the noise floor level of the input signal.
 - For **Ext Front** or **Ext Rear**, the level range is -5.00 to $+5.00$ V with 1 or 10 mV resolution.
 - **Slope** - Allows you to toggle the trigger slope between **Pos** at the positive-going edge and **Neg** at the negative-going edge of the burst signal.

There are other keys under the **Trigger** key as follows:

- **Trig Holdoff** - Allows you to set the period of time before the next trigger can occur. The range is $0.000\ \mu\text{s}$ to 500.0 ms with $1\ \mu\text{s}$ resolution.
- **Auto Trig** - Allows you to specify a time for a trigger timeout and

Setting Up the Mode

1xEV-DO Mode

toggle the auto trigger function between **On** and **Off**. The range is 1.000 ms to 1.000 ks with 1 μ s resolution. If no trigger occurs by the specified time, a trigger is automatically generated.

- **Frame Timer** - Allows you to access the menu to manually control the frame timer:
 - **Period** - Allows you to set the period of the frame clock. The range is 0.000 ns to 559.0000 ms with 1 ps resolution.
 - **Offset** - Allows you to set the offset of the frame clock. The range is 0.000 to 10.00 s with 100 ns resolution over 1.000 μ s range.
 - **Reset Offset Display** - Allows you to display without any offset of the frame clock.
 - **Sync Source** - Allows you to access the menu to select one of the sources to be synchronized with.
 - Off** - Allows you to turn the synchronizing source off for asynchronous tests.
 - RF Burst (Wideband)** - Allows you to select the RF burst signal as the synchronizing source.
 - Ext Front** - Allows you to select the external input signal from the front-panel input port as the synchronizing source.
 - Ext Rear** - Allows you to select the external input signal from the rear panel input port as the synchronizing source.

The trigger default settings are listed in the following table:

Trigger Default Settings	
RF Burst:	
Delay	0.000 μ s
Peak Level	-6.00 dB
Slope	Pos
Video (Envlp):	
Delay	0.000 μ s
Level	-6.00 dBm
Slope	Pos
Ext Front:	
Delay	0.000 μ s
Level	2.00 V
Slope	Pos
Ext Rear:	
Delay	0.000 μ s
Level	2.00 V
Slope	Pos
Trig Holdoff	0.000 ms

Trigger Default Settings	
Auto Trig	100.0 ms; Off
Frame Timer:	
Period	26.666667 ms
Offset	0.000 ms
Reset Offset Display	(effective unless Offset is 0.000 ms)
Sync Source	Off

Configuring the Demod RF Carrier

When **Device** is set to **BTS (Fwd)**, the **Demod** key under **Mode Setup** is available for setting the RF carrier to either **Single** or **Multi**, which is used to measure **Code Domain**, **Mod Accuracy (Composite Rho)**, or **QPSK EVM** with a single carrier or multiple carriers.

Demod Default Setting	
Demod: RF Carrier	Single

Changing the Frequency Channel

After selecting the desired mode setup, you will need to select the desired center frequency and the center frequency step. The selections made here will apply to all measurements in the mode. Press the **FREQUENCY Channel** key to access the following menu:

- **Center Freq** - Allows you to enter a frequency that corresponds to the desired RF channel to be measured. This is the current instrument center frequency. The range is 1.000 kHz to 4.32140 GHz with 1 Hz resolution.
- **CF Step** - Allows you to enter a center frequency step to shift the measurement segment, and to toggle the step function between **Auto** and **Man**. If set to **Auto**, the **CF Step** value automatically changes according to the selection of the standard. The range is 1.000 kHz to 1.00000 GHz with 1 Hz resolution.

Frequency Channel Default Settings	
FREQUENCY Channel:	
Center Freq	1.00000 GHz
CF Step	1.25000 MHz, Auto

1xEV-DO Measurement Key Flow

The key flow diagrams, shown in a hierarchical manner on the following pages, will help grasp the overall functional relationships for the front-panel keys and the keys displayed at the extreme right side of the screen. The diagrams are:

- “MODE Selection Key Flow” on page 79
- “Mode Setup/FREQUENCY Channel Key Flow (1 of 2)” on page 80
- “Measurement Selection Key Flow” on page 82
- “Channel Power Measurement Key Flow” on page 82
- “Power vs. Time Measurement Key Flow (1 of 2)” on page 84
- “Intermodulation Measurement Key Flow” on page 83
- “Spurious Emissions & ACP Measurement Key Flow (1 of 3)” on page 86
- “Occupied Bandwidth Measurement Key Flow” on page 89
- “Forward Link Code Domain Measurement Key Flow (1 of 3)” on page 90
- “Reverse Link Code Domain Measurement Key Flow (1 of 3)” on page 93
- “Forward Link Mod Accuracy Measurement Key Flow (1 of 5)” on page 96
- “Reverse Link Mod Accuracy Measurement Key Flow (1 of 4)” on page 101
- “QPSK EVM Measurement Key Flow (1 of 2)” on page 105
- “Power Statistics CCDF Measurement Key Flow” on page 107
- “Spectrum (Freq Domain) Measurement Key Flow (1 of 4)” on page 108
- “Waveform (Time Domain) Measurement Key Flow (1 of 2)” on page 112

Use these flow diagrams as follows:

- There are some basic conventions:

Meas Setup

An oval represents one of the front-panel keys.

EDGE EVM

This box represents one of the keys displayed.

<for EVM>

This represents an explanatory description on its specific key.

Avg Bursts 20 On|Off

This box shows how the key default condition is displayed. Default

parameters or values are underlined wherever possible.

- Start from the upper left corner of each measurement diagram. Go to the right, and go from the top to the bottom.
- When changing a key from auto (with underline) to manual, just press that key one time.
- When entering a numeric value of **FREQUENCY Channel**, for example, use the numeric keypad and terminate the entry with the appropriate unit selection from the softkeys displayed.
- When entering a numeric value without a unit, like **Avg Number**, use the numeric keypad and terminate the entry with the **Enter** front-panel key.
- Instead of using the numeric keypad to enter a value, it may be easier to use the RPG knob or **Up/Down** keys.

Figure 3-1

MODE Selection Key Flow

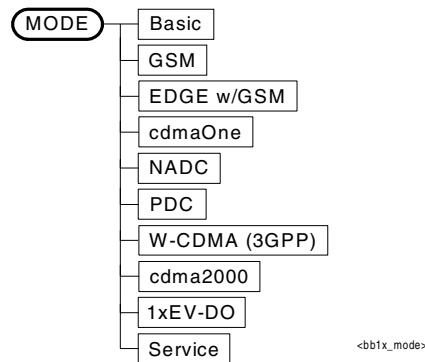

Setting Up the Mode
1xEV-DO Measurement Key Flow

Figure 3-2 Mode Setup/FREQUENCY Channel Key Flow (1 of 2)

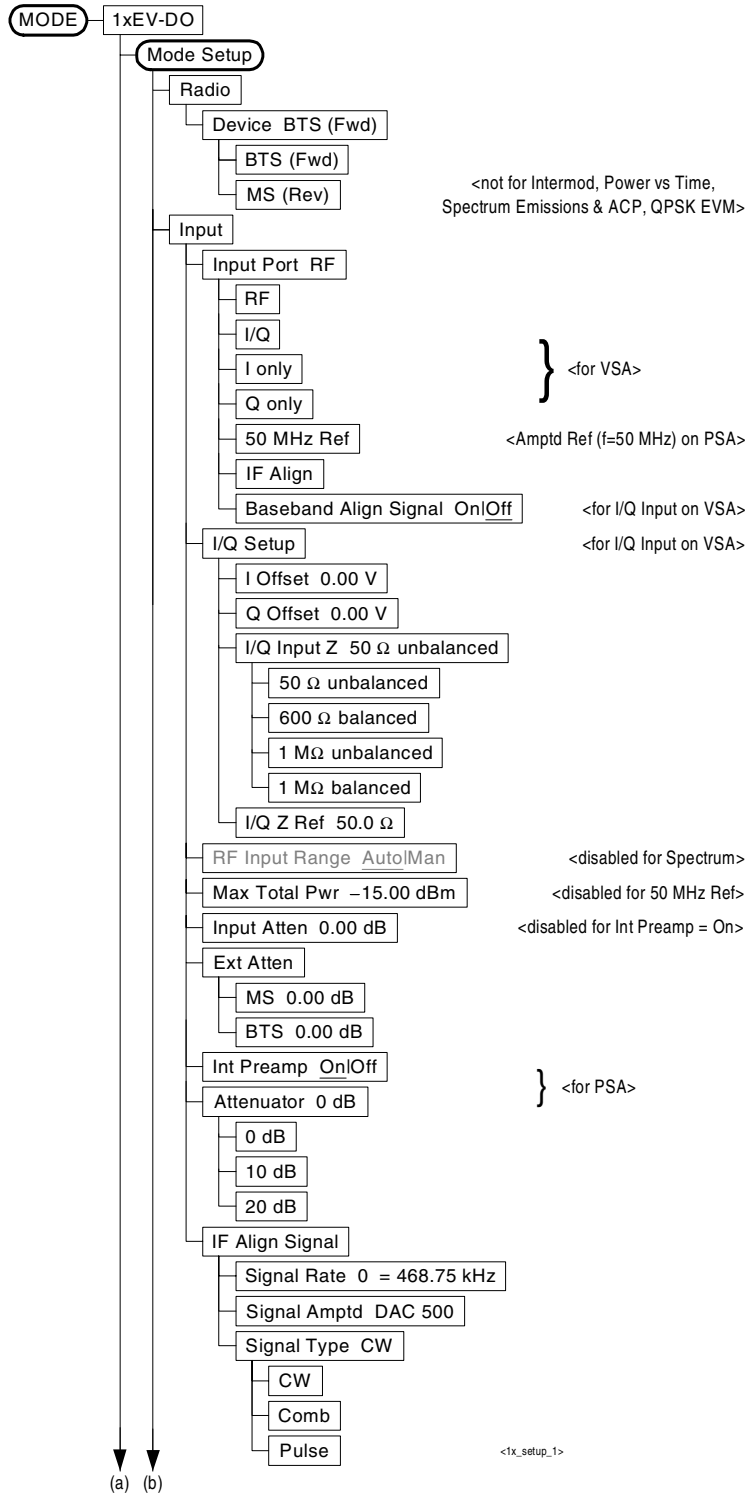

Figure 3-3 Mode Setup/FREQUENCY Channel Key Flow (2 of 2)

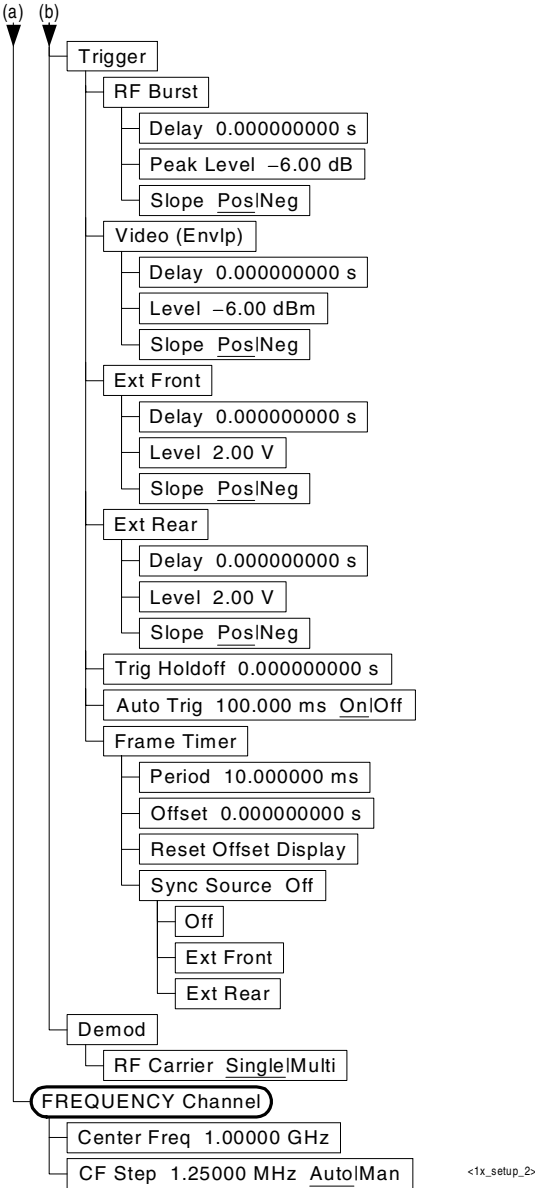

Figure 3-4 Measurement Selection Key Flow

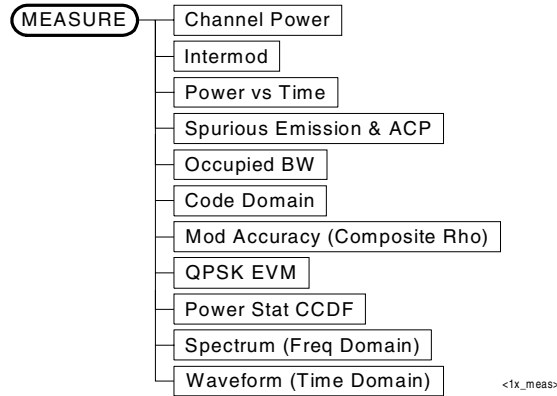

Figure 3-5 Channel Power Measurement Key Flow

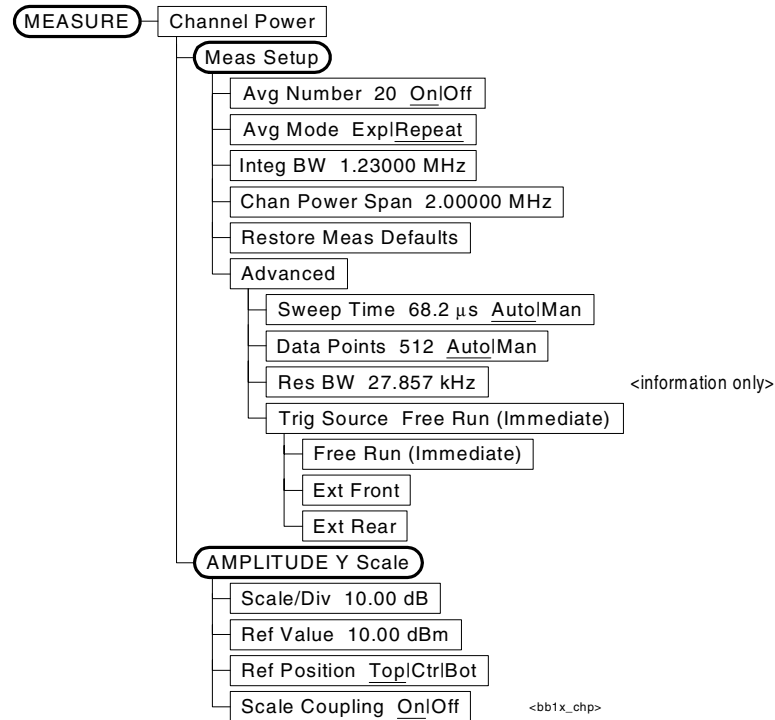

Figure 3-6 Intermodulation Measurement Key Flow

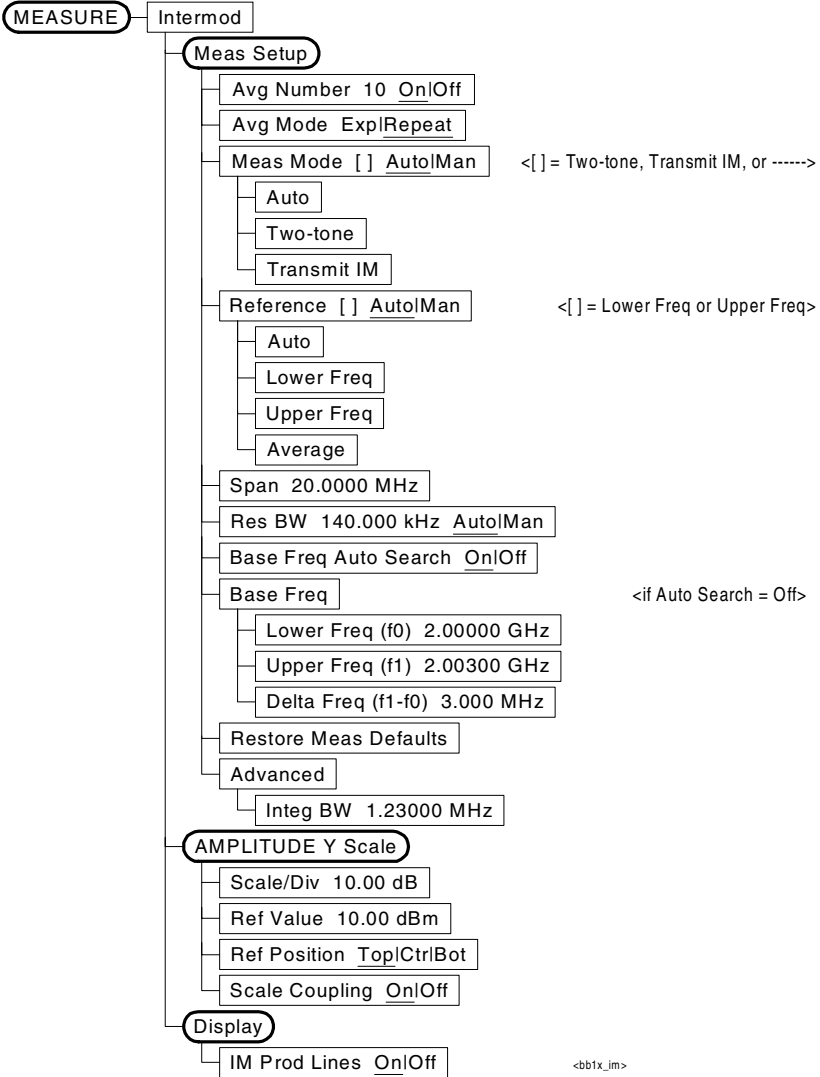

Figure 3-7 Power vs. Time Measurement Key Flow (1 of 2)

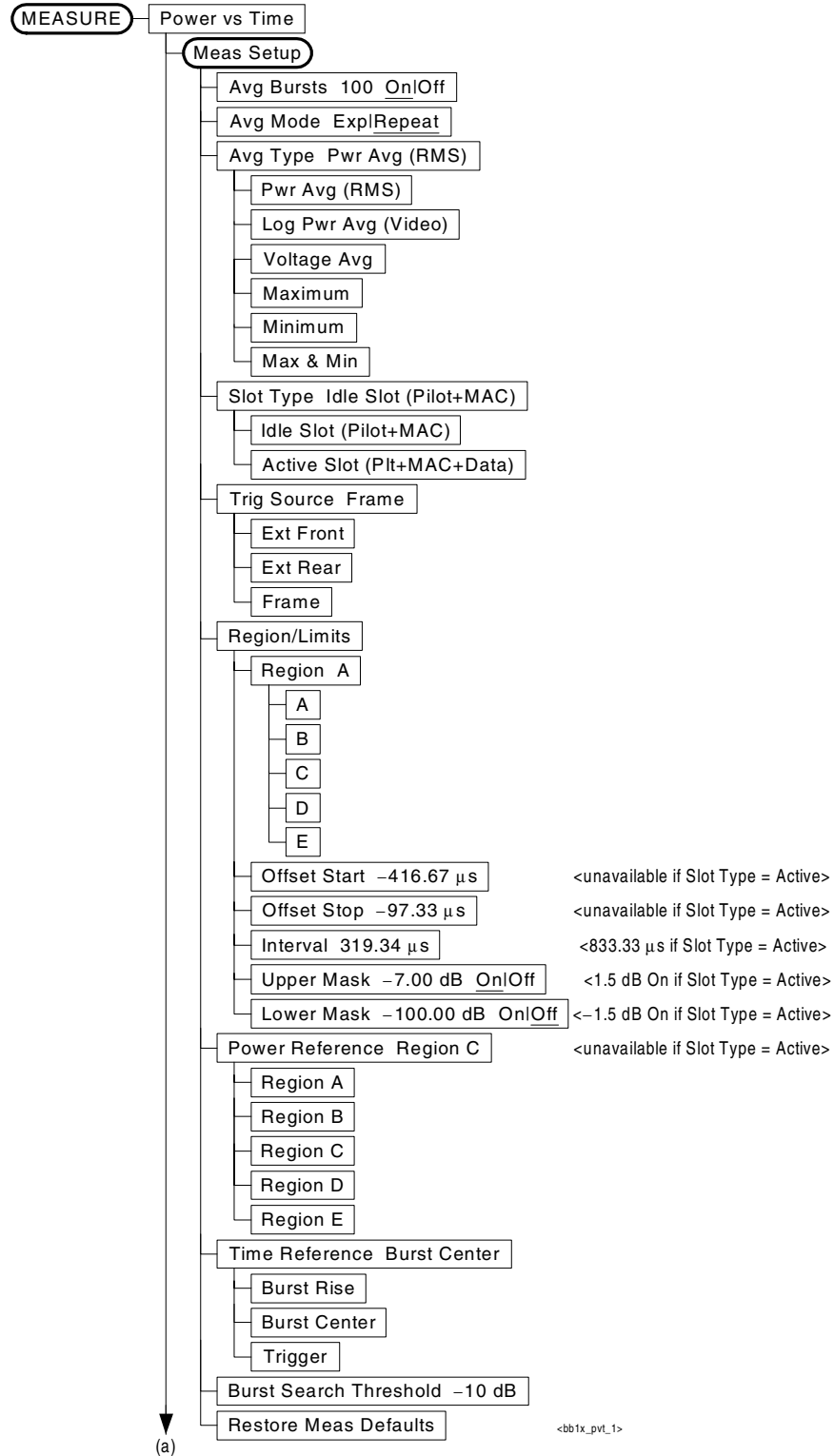

Figure 3-8 Power vs. Time Measurement Key Flow (2 of 2)

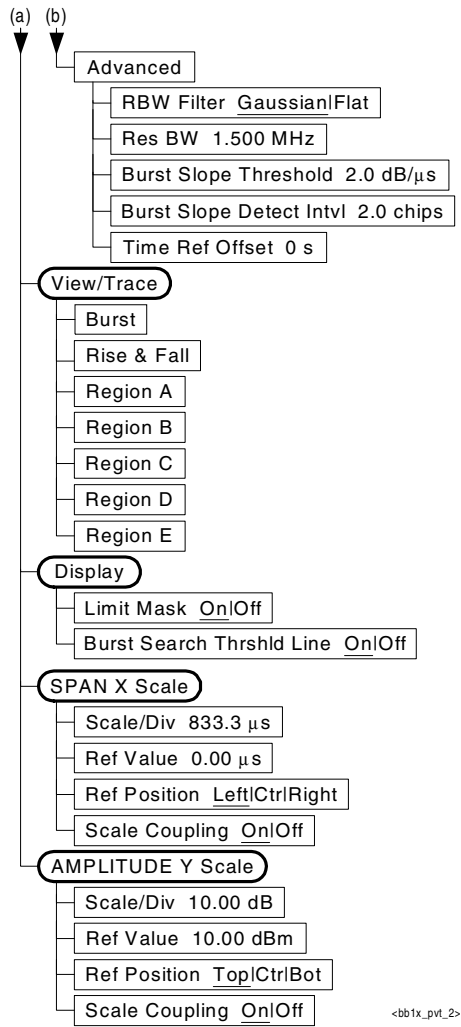

Figure 3-9 Spurious Emissions & ACP Measurement Key Flow (1 of 3)

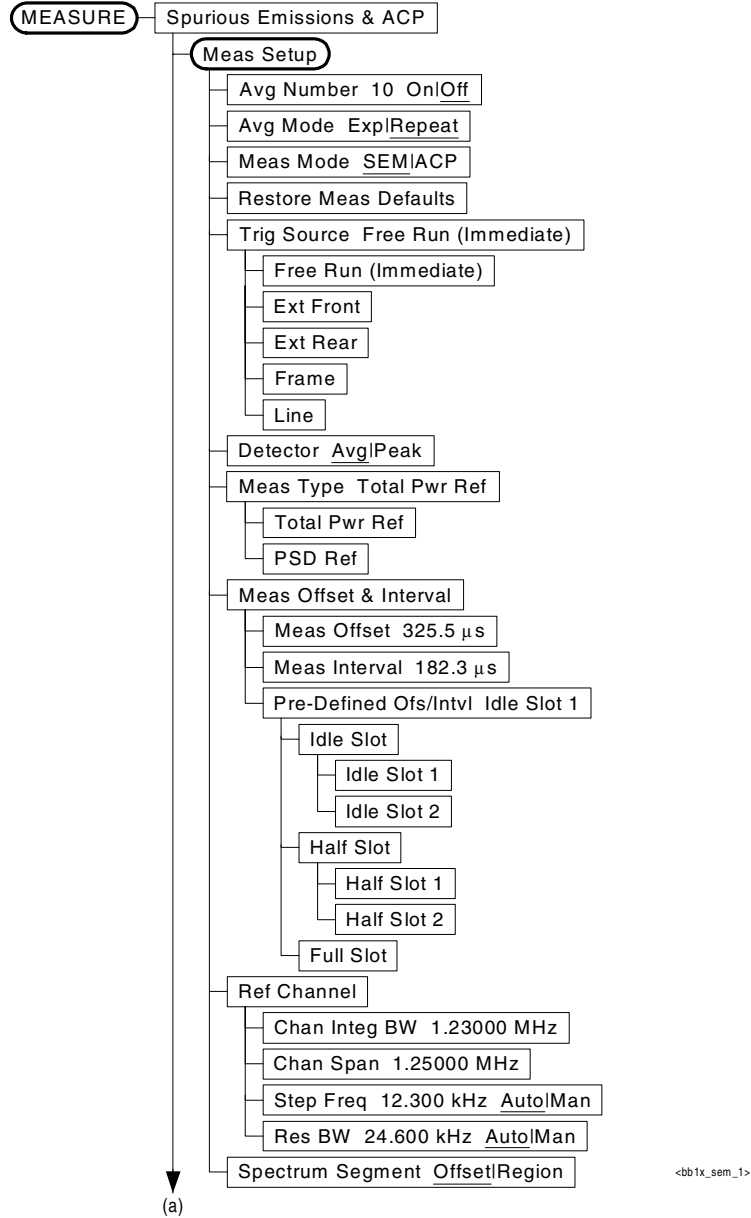

Figure 3-10 Spurious Emissions & ACP Measurement Key Flow (2 of 3)

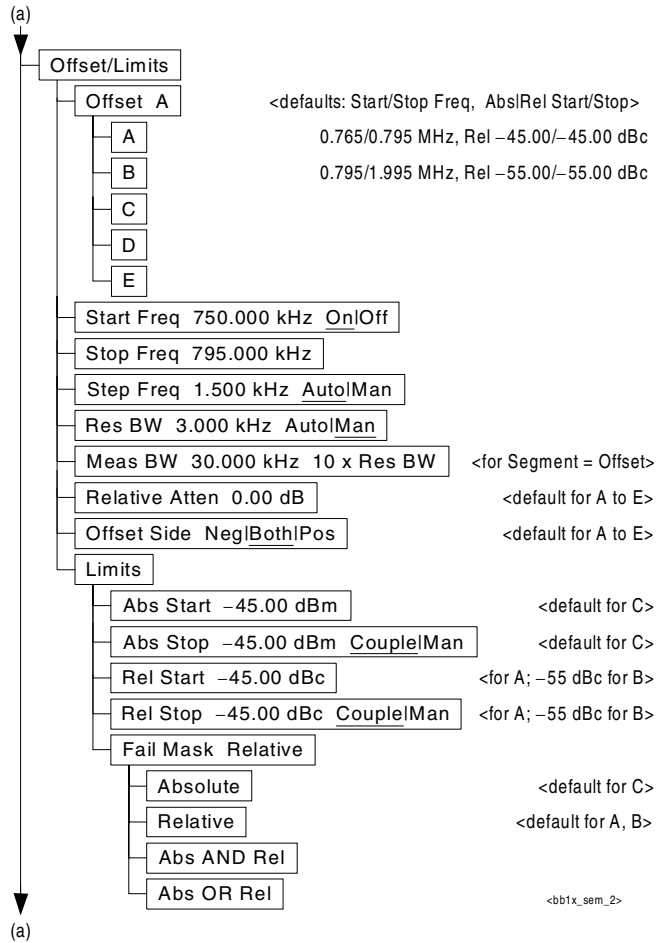

Figure 3-11 Spurious Emissions & ACP Measurement key Flow (3 of 3)

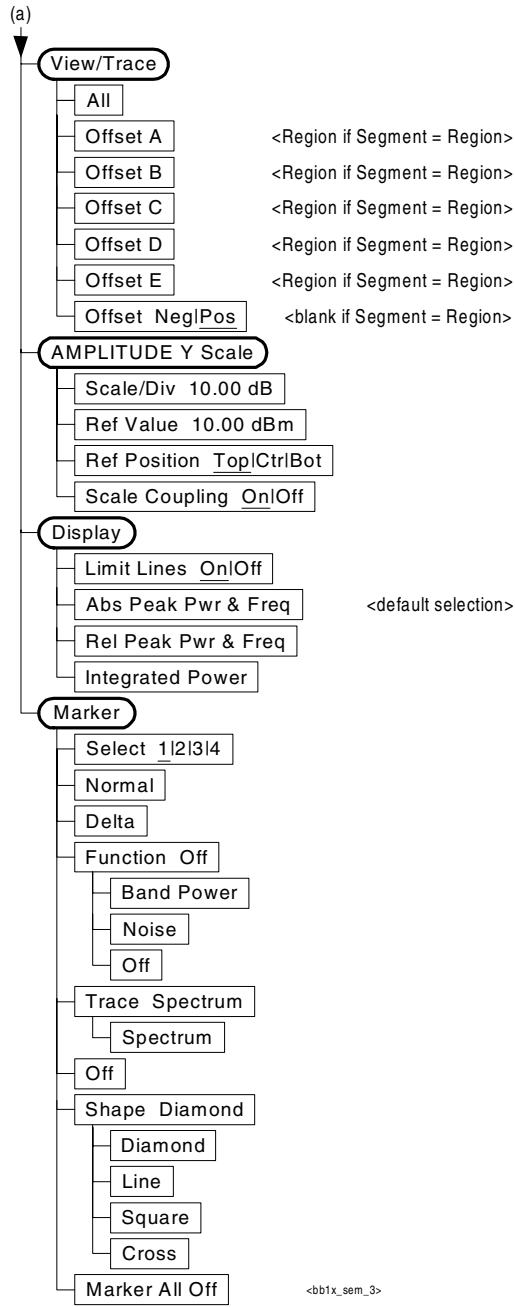

Figure 3-12 Occupied Bandwidth Measurement Key Flow

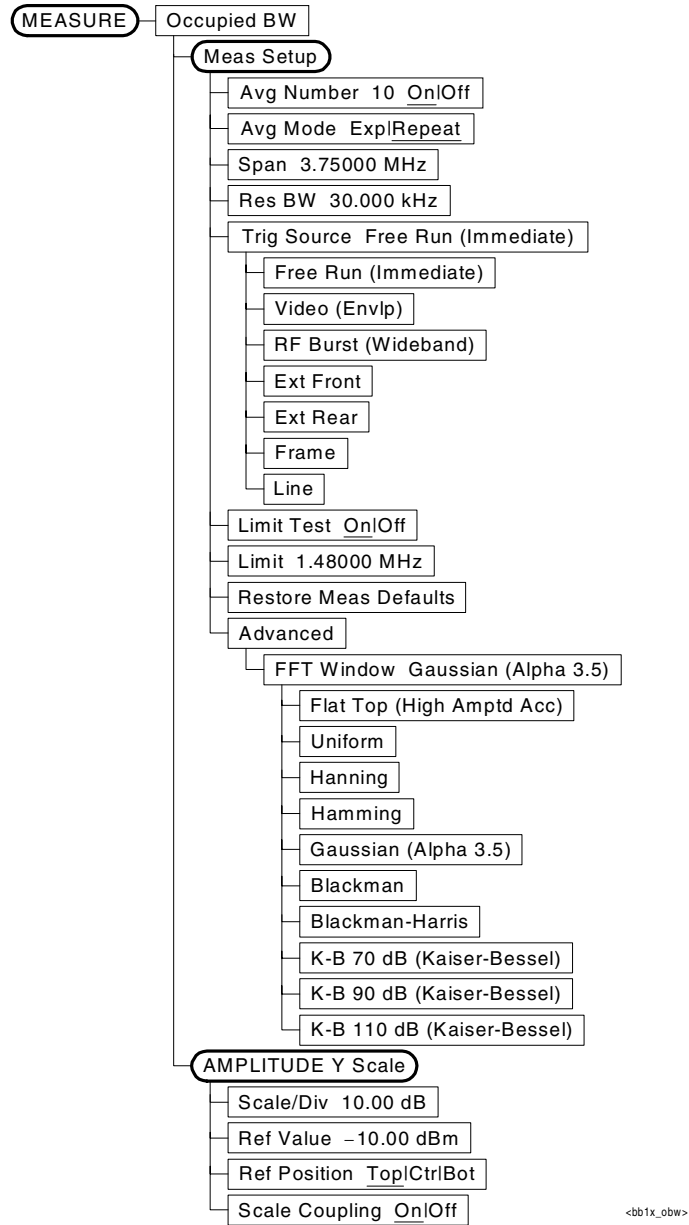

Figure 3-13 Forward Link Code Domain Measurement Key Flow (1 of 3)

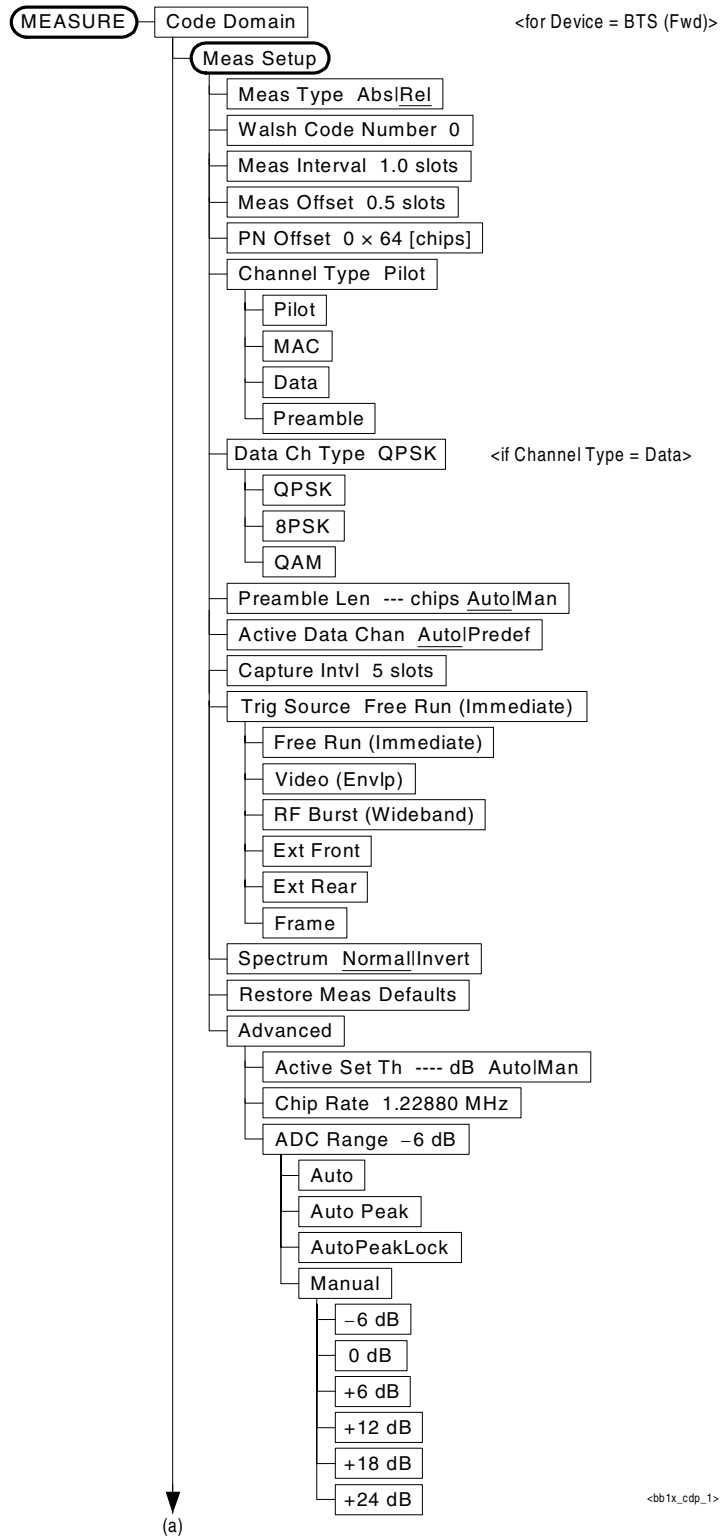

Figure 3-14 Forward Link Code Domain Measurement Key Flow (2 of 3)

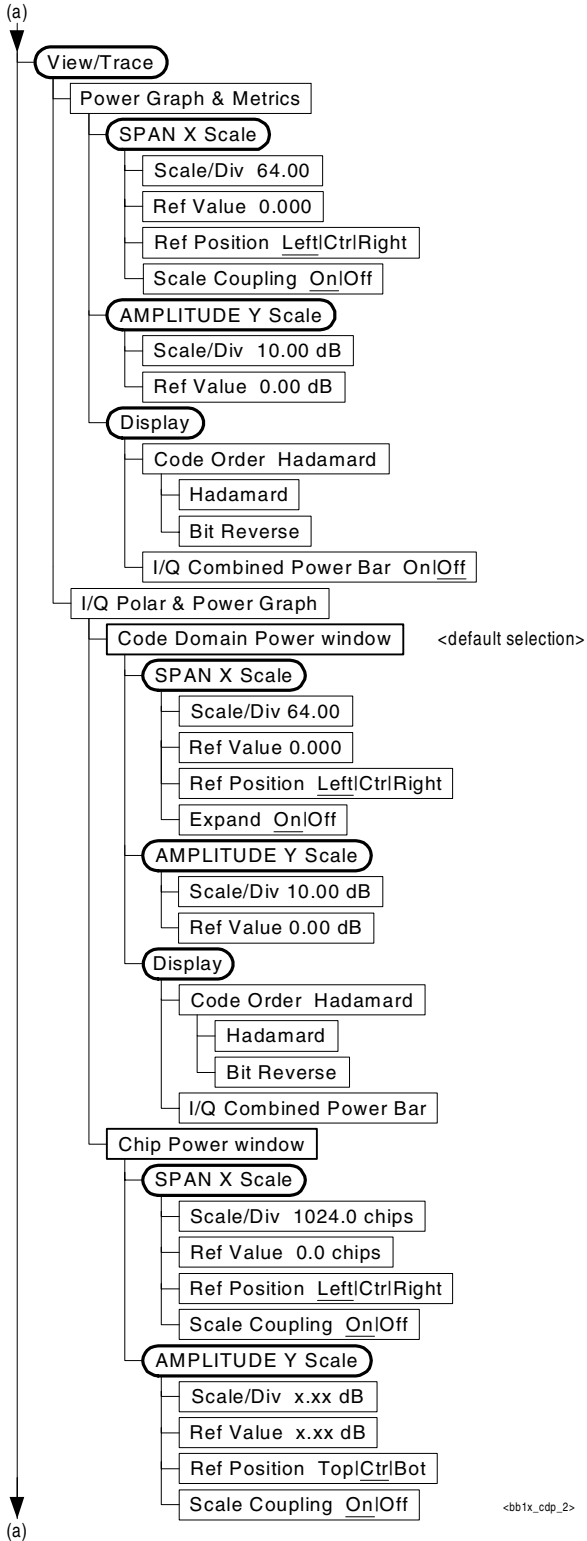

Figure 3-15 Forward Link Code Domain Measurement Key Flow (3 of 3)

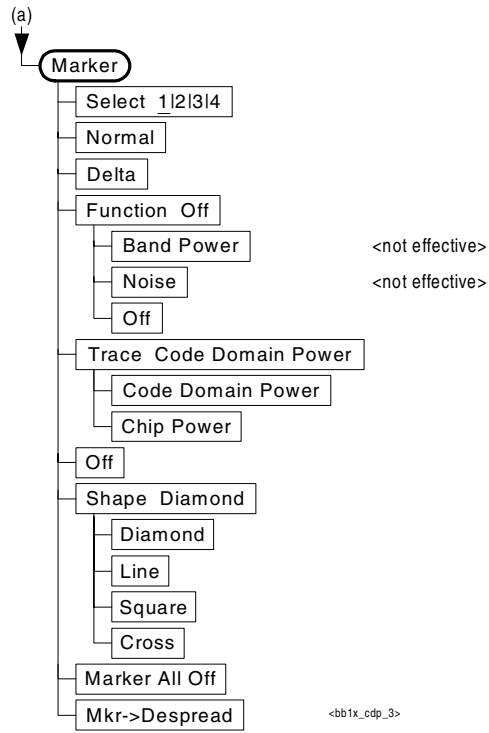

Figure 3-16 Reverse Link Code Domain Measurement Key Flow (1 of 3)



<bb1x_cdp_1r>

(a)

Figure 3-17 Reverse Link Code Domain Measurement Key Flow (2 of 3)

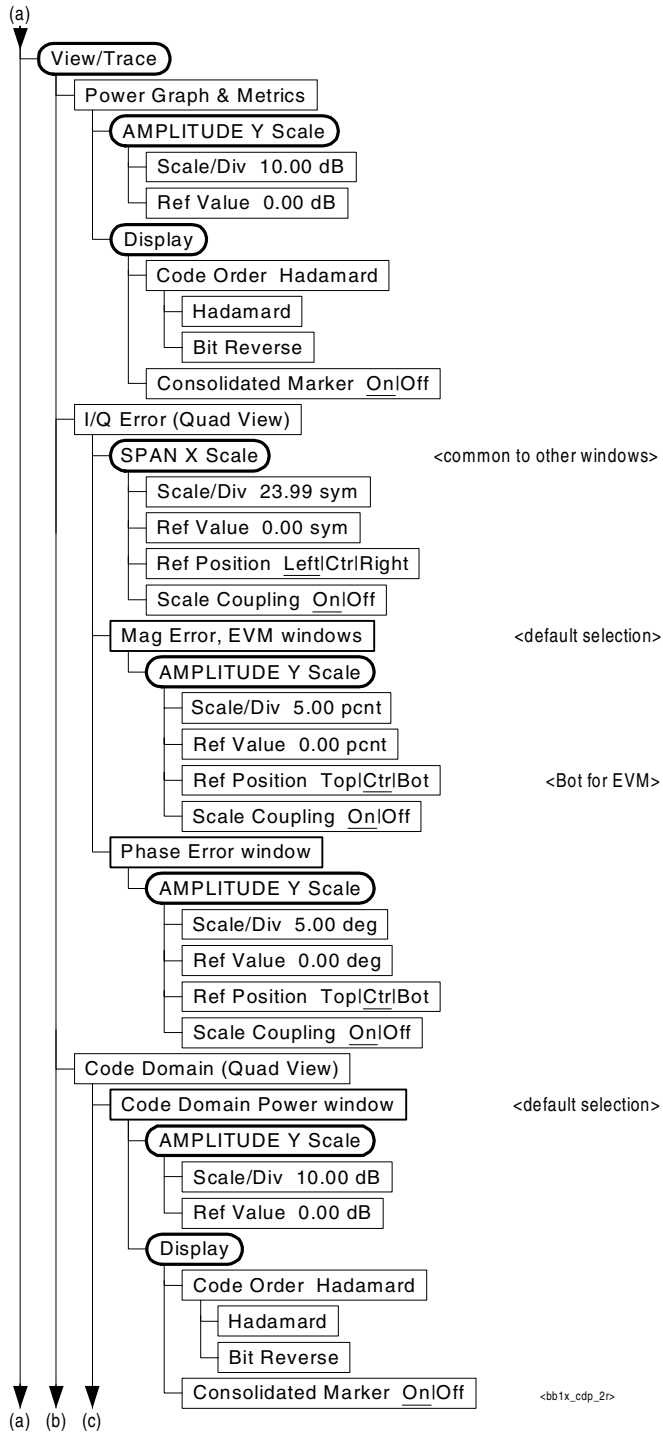

Figure 3-18 Reverse Link Code Domain Measurement Key Flow (3 of 3)

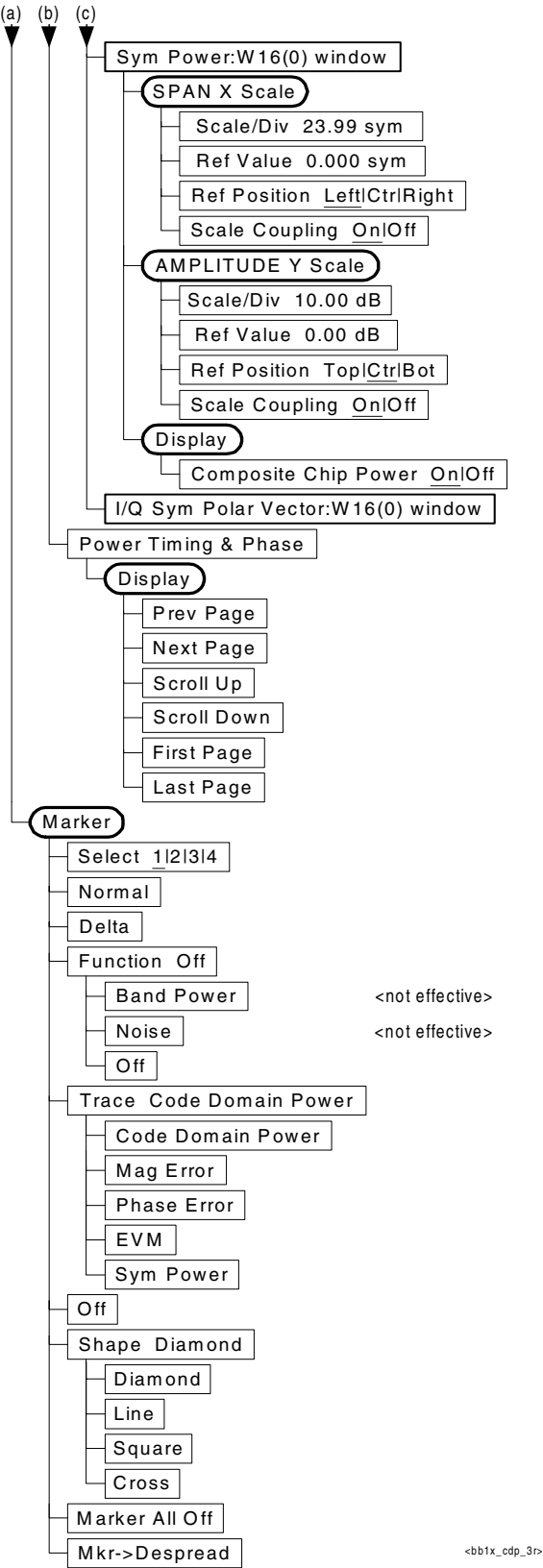

Figure 3-19 Forward Link Mod Accuracy Measurement Key Flow (1 of 5)

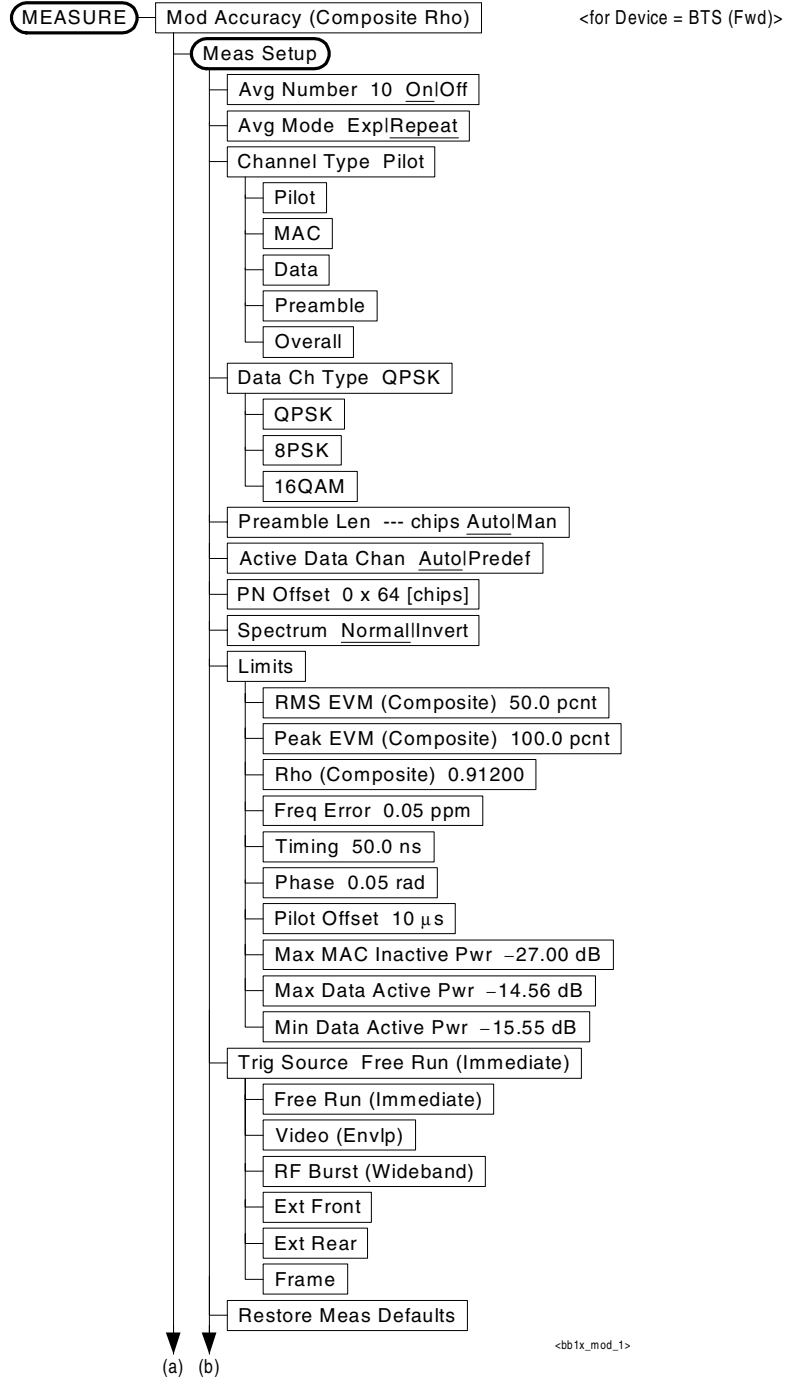

Figure 3-20 Forward Link Mod Accuracy Measurement Key Flow (2 of 5)

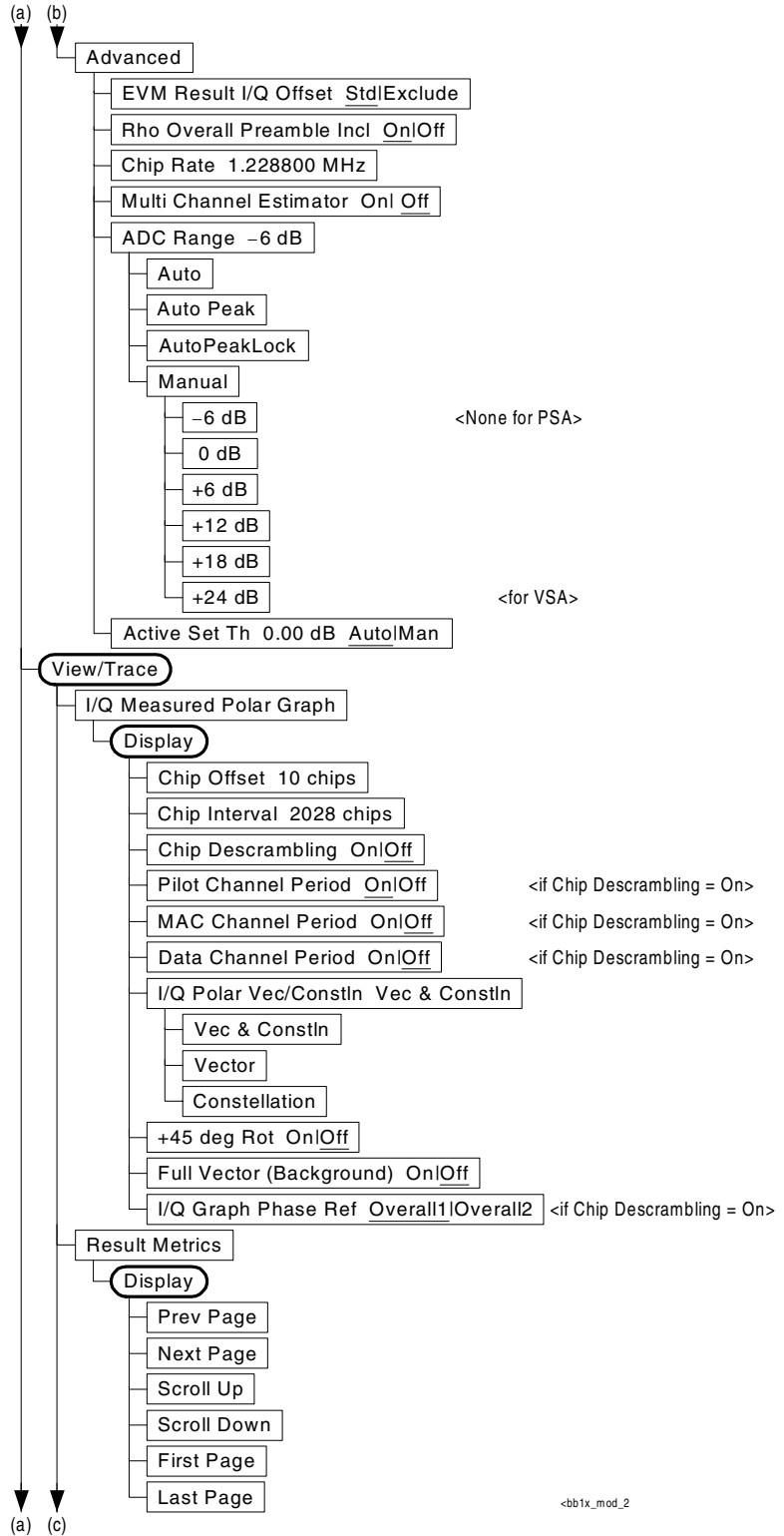

Figure 3-21 Forward Link Mod Accuracy Measurement Key Flow (3 of 5)

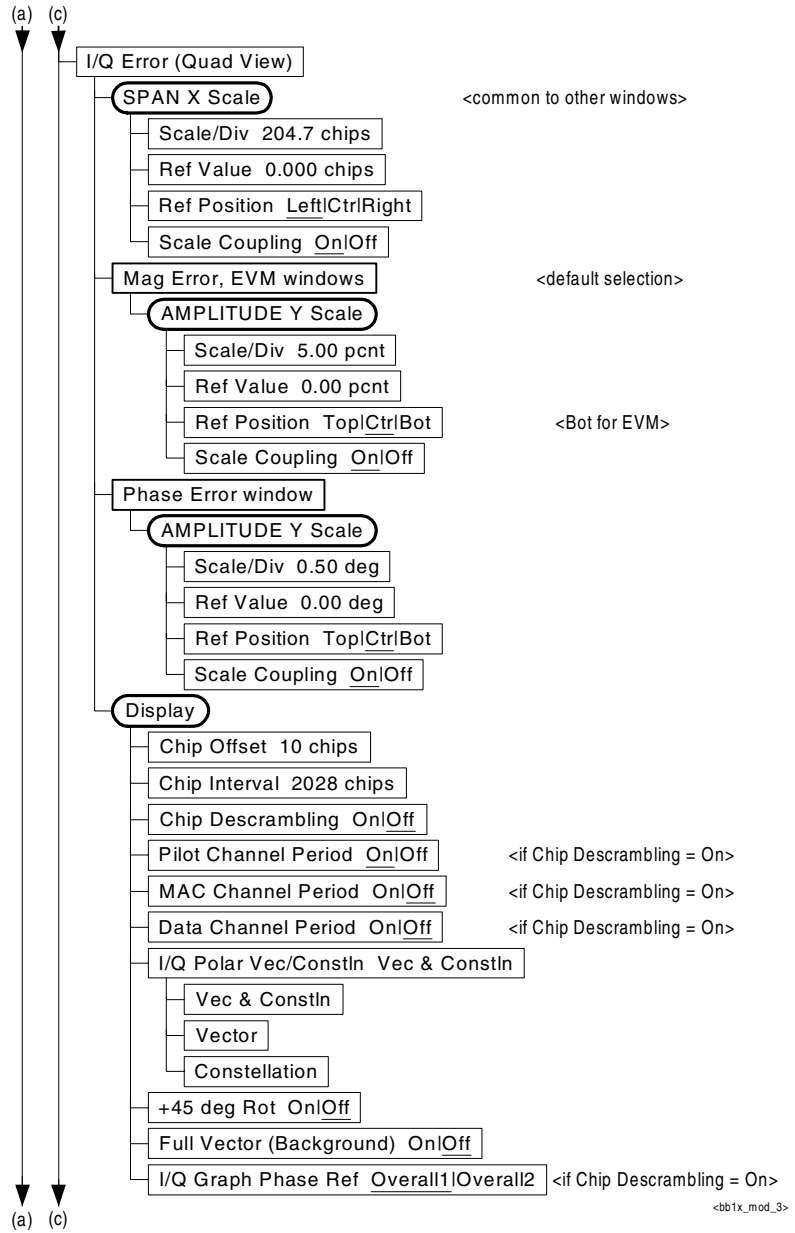

Figure 3-22 Forward Link Mod Accuracy Measurement Key Flow (4 of 5)



<bb1x_mod_4

Figure 3-23 Forward Link Mod Accuracy Measurement Key Flow (5 of 5)

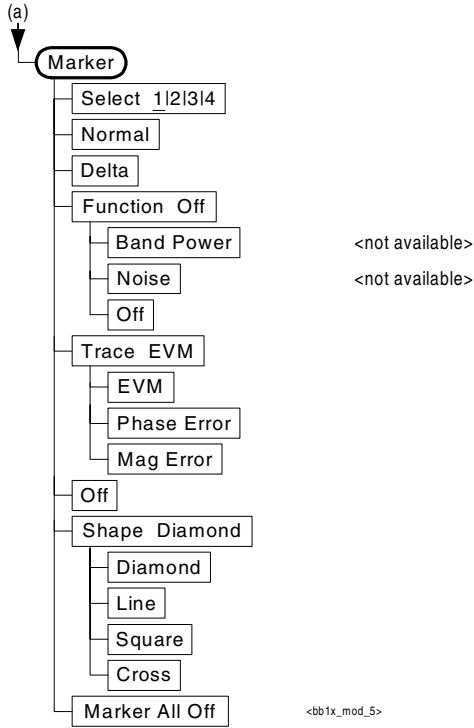

Figure 3-24 Reverse Link Mod Accuracy Measurement Key Flow (1 of 4)

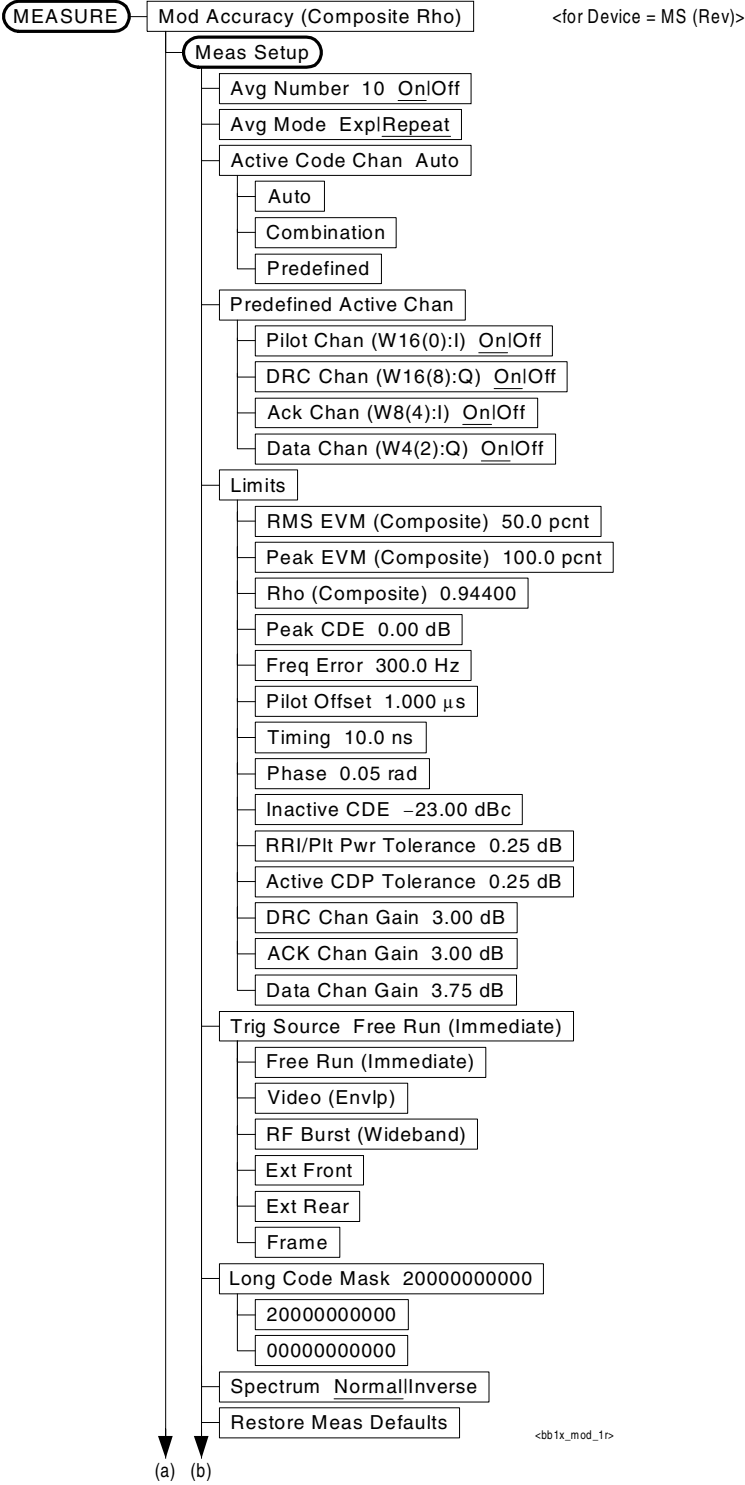

Figure 3-25 Reverse Link Mod Accuracy Measurement Key Flow (2 of 4)

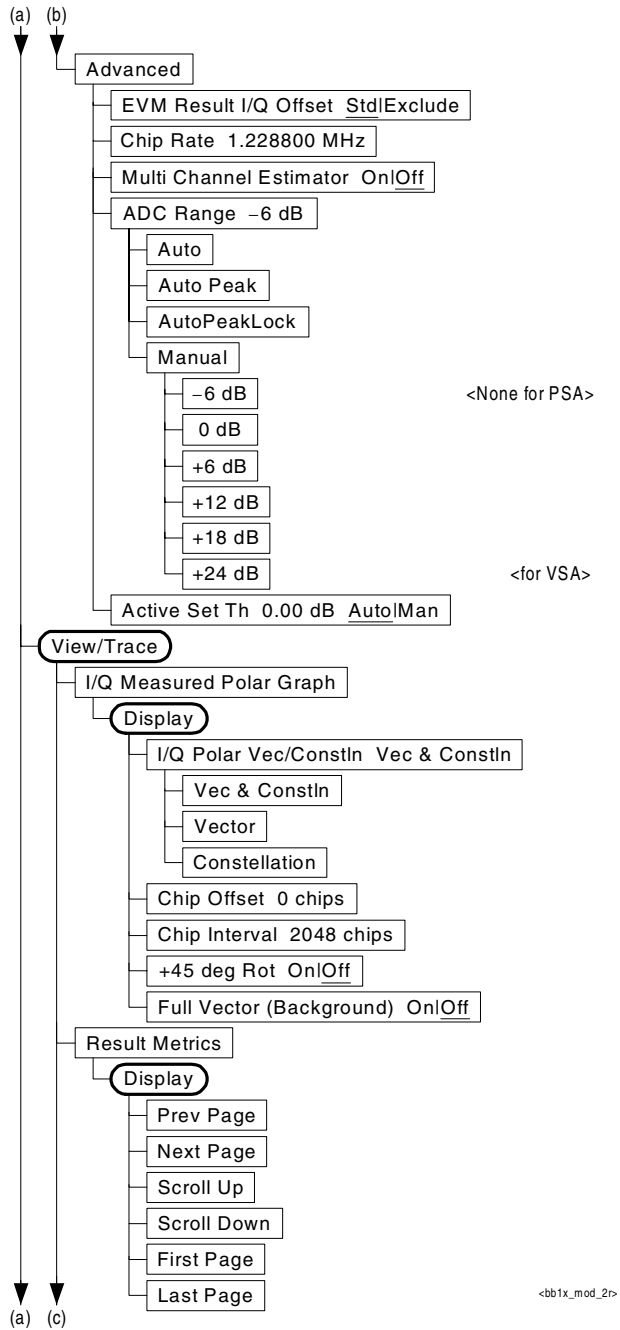

Figure 3-26 Reverse Link Mod Accuracy Measurement Key Flow (3 of 4)

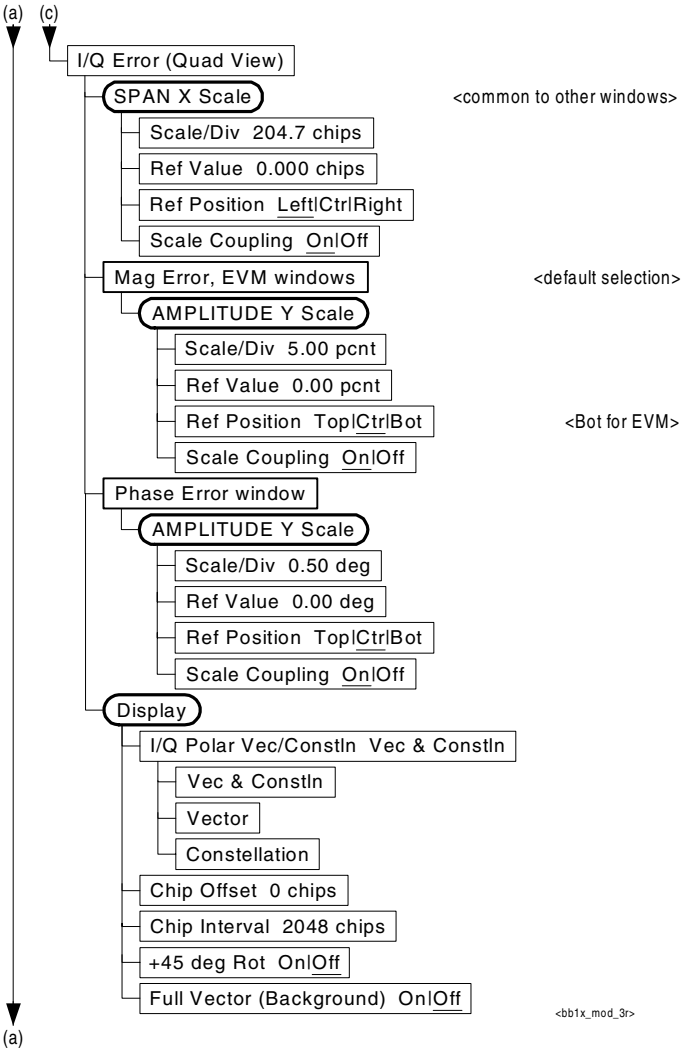

Figure 3-27 Reverse Link Mod Accuracy Measurement Key Flow (4 of 4)

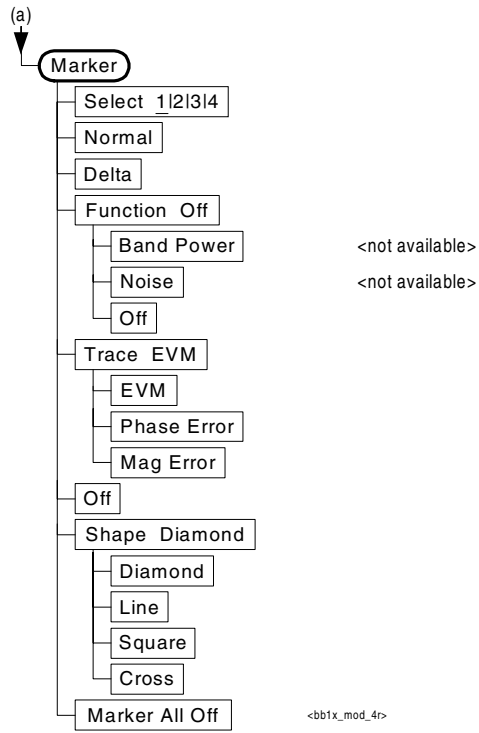
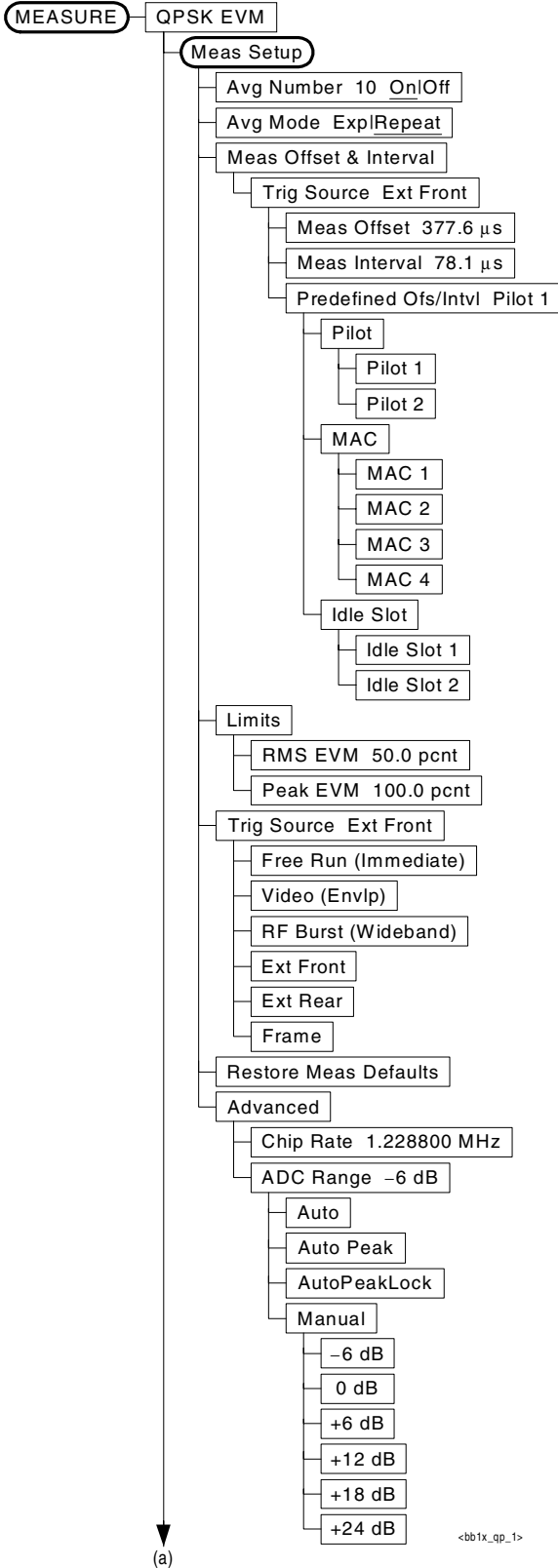

Figure 3-28 QPSK EVM Measurement Key Flow (1 of 2)



(a)

<bb1x_qp_1>

Figure 3-29 QPSK EVM Measurement Key Flow (2 of 2)

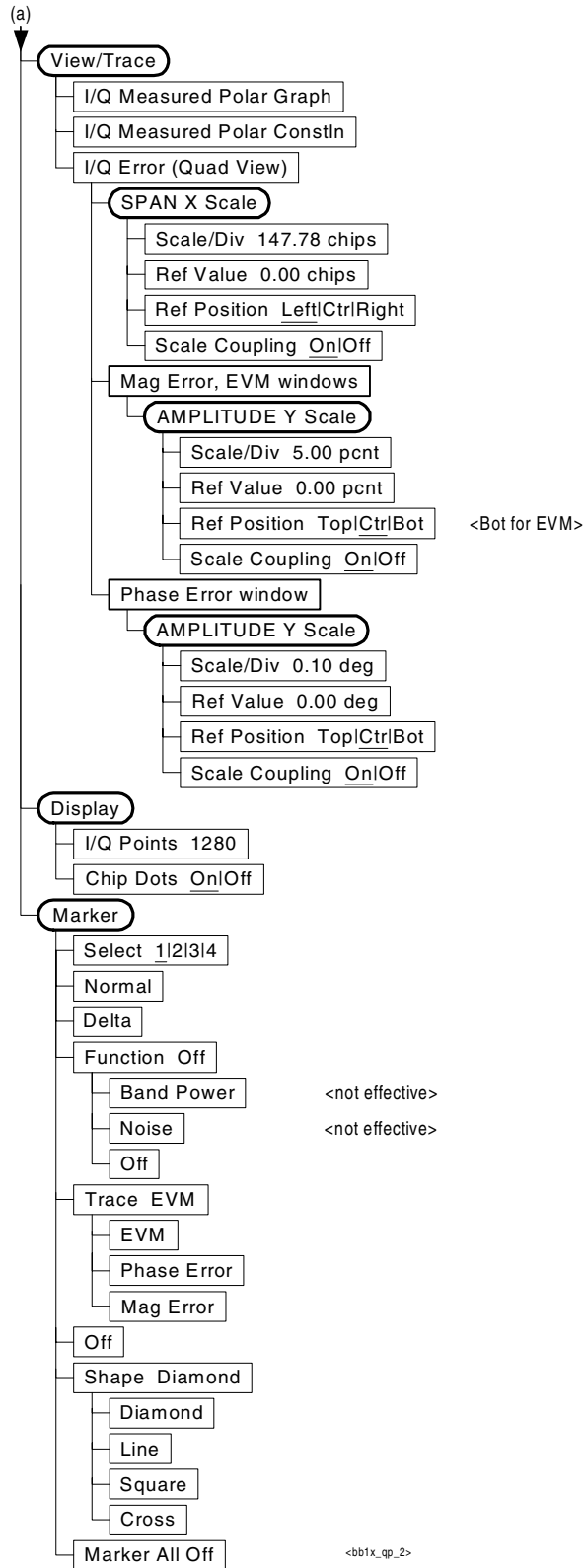

Figure 3-30 Power Statistics CCDF Measurement Key Flow

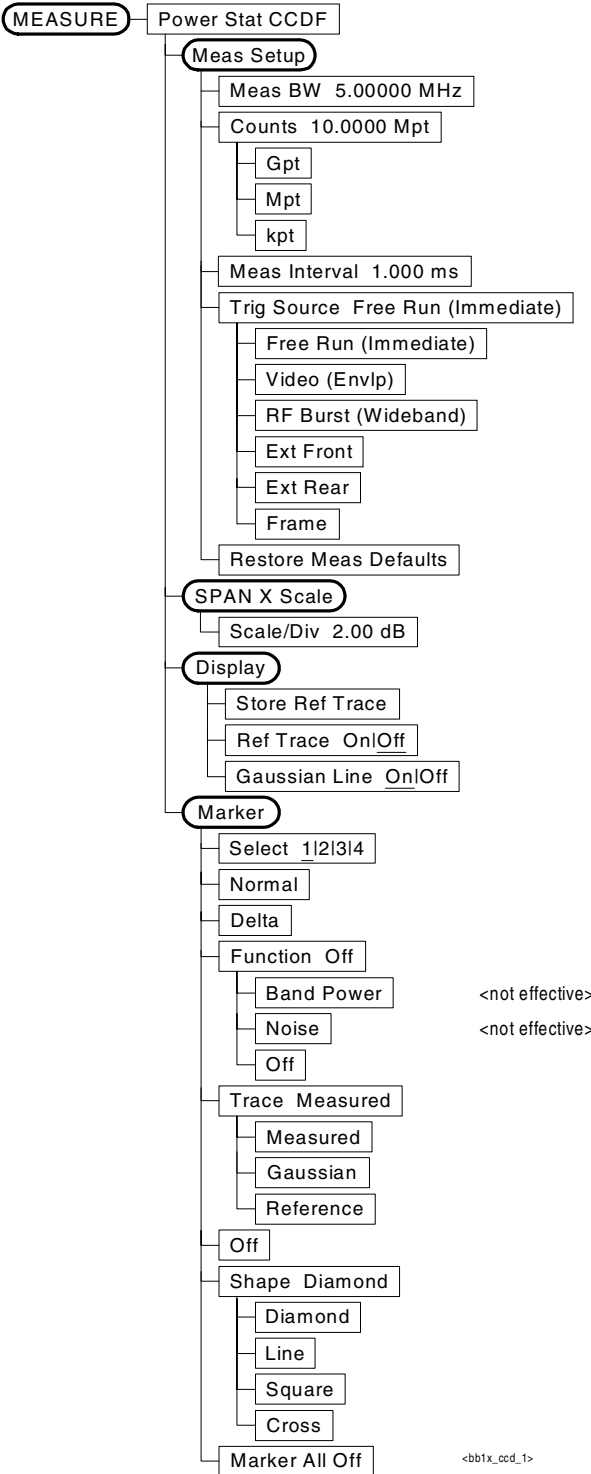

Figure 3-31 Spectrum (Freq Domain) Measurement Key Flow (1 of 4)

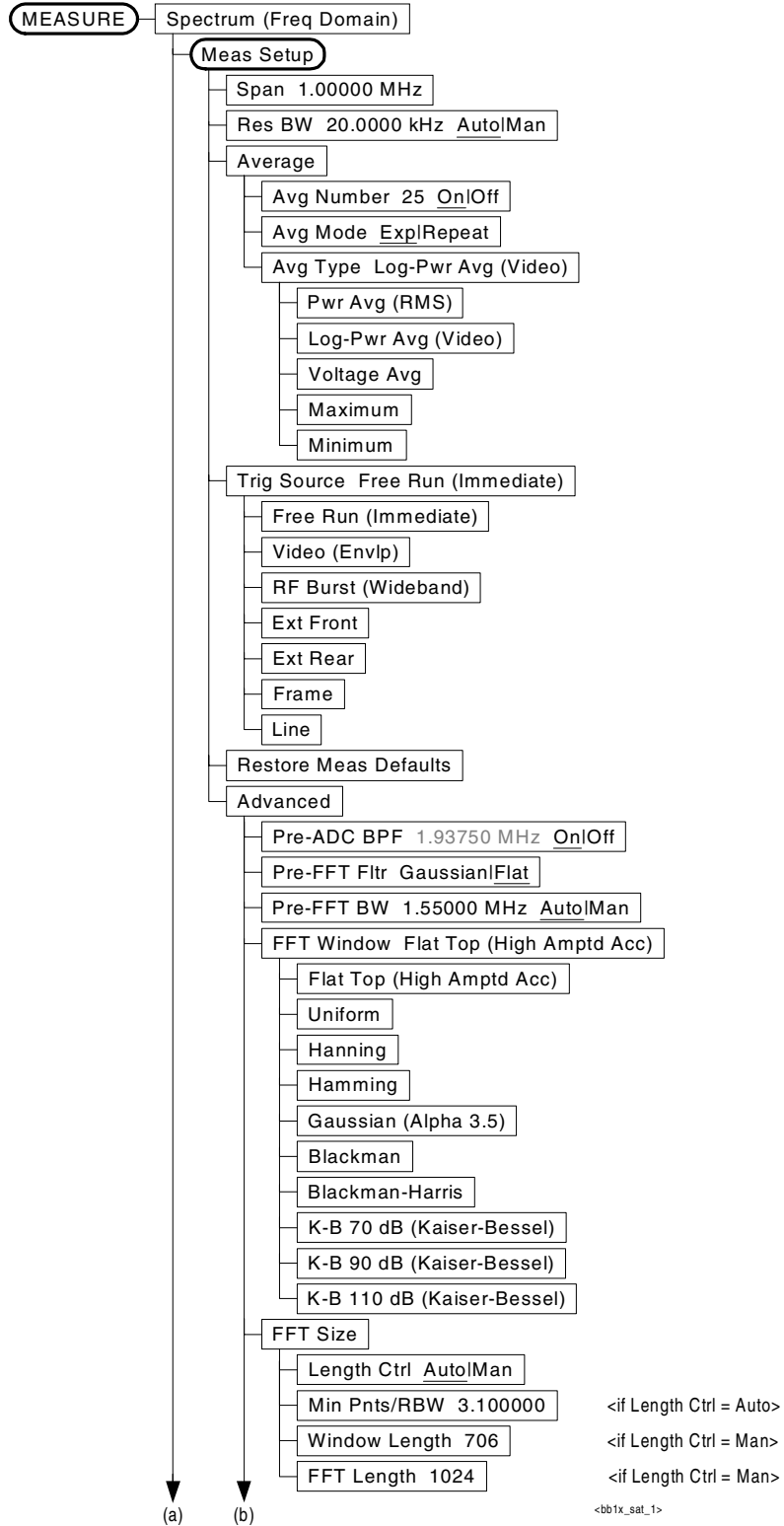
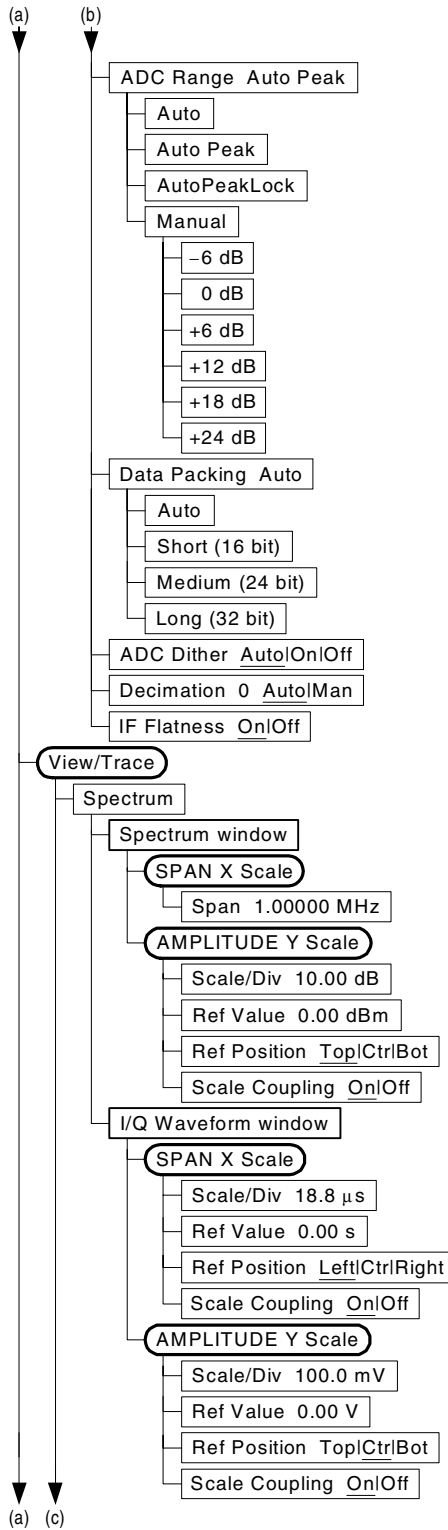

Figure 3-32 Spectrum (Freq Domain) Measurement Key Flow (2 of 4)



<bb1x_sa_2>

Figure 3-33 Spectrum (Freq Domain) Measurement Key Flow (3 of 4)

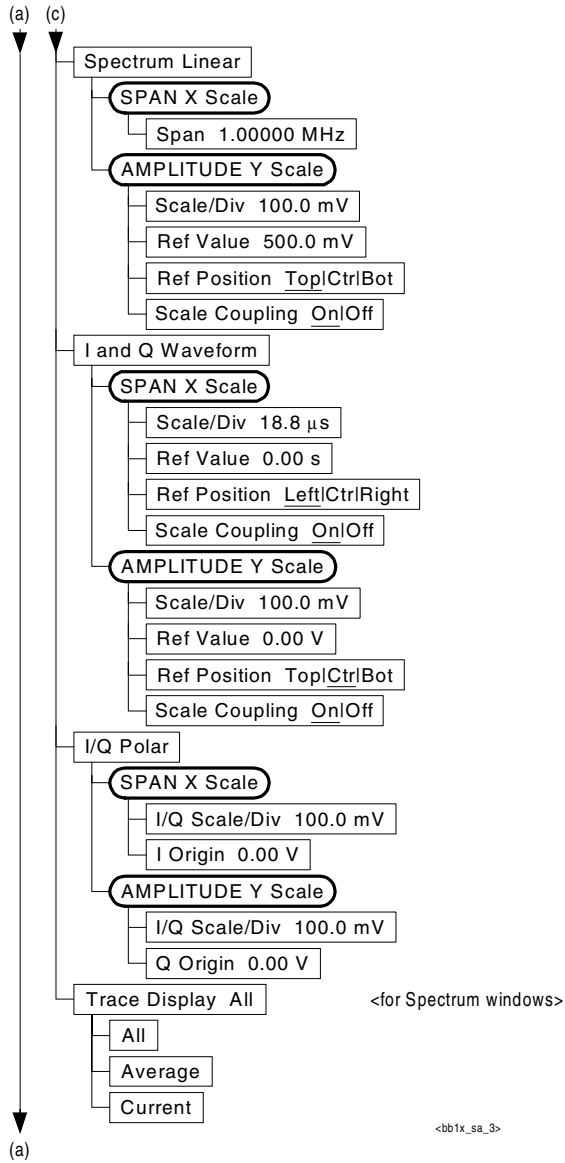

Figure 3-34 Spectrum (Freq Domain) Measurement Key Flow (4 of 4)

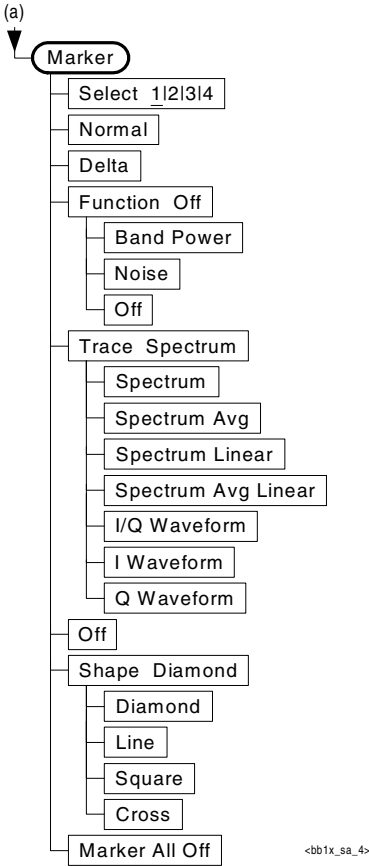
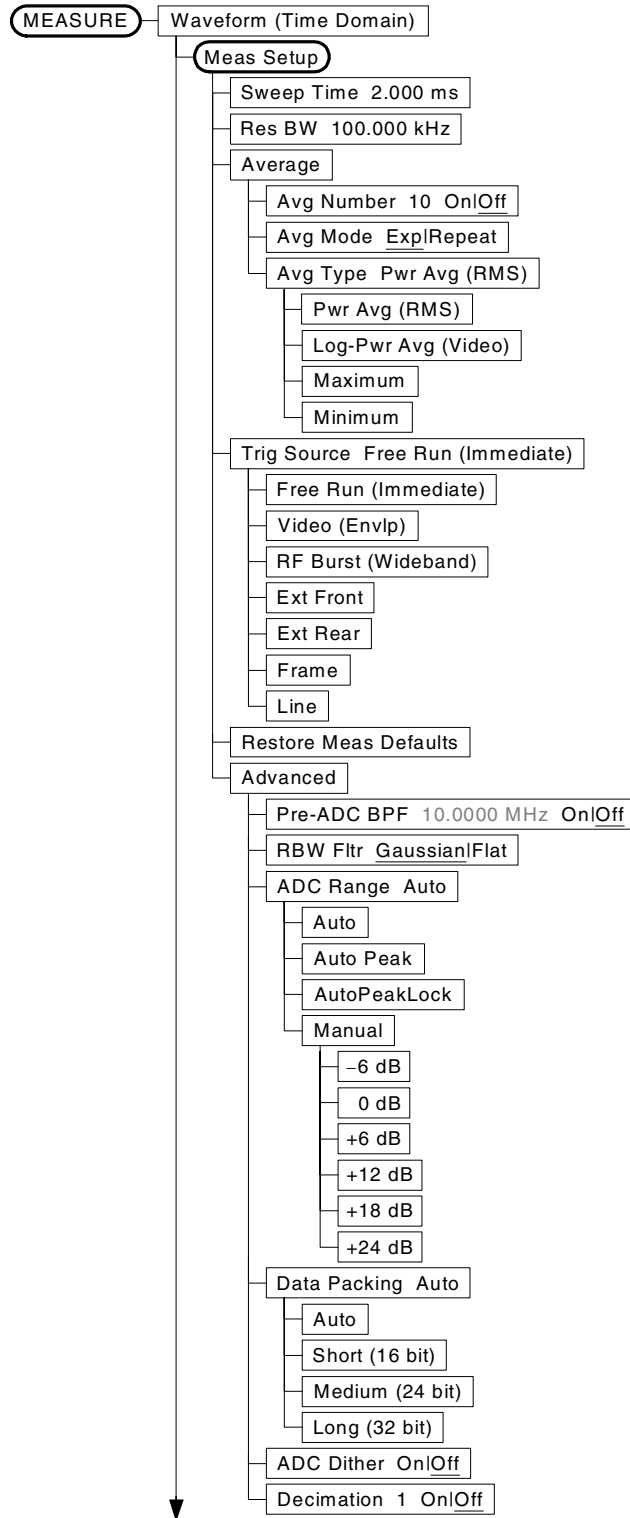

Figure 3-35 Waveform (Time Domain) Measurement Key Flow (1 of 2)



(a)

<bb1x_wvf_1>

Figure 3-36 Waveform (Time Domain) Measurement Key Flow (2 of 2)

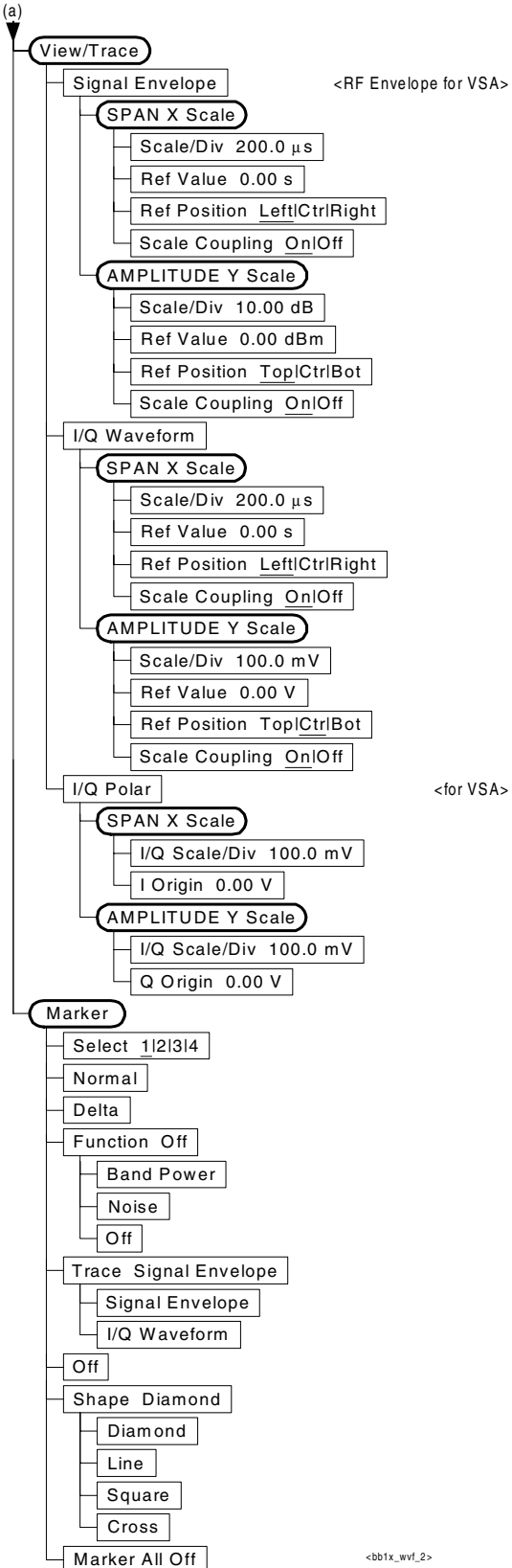

Installing Optional Measurement Personalities

When you install a measurement personality, you follow a two step process.

1. Install the measurement personality firmware into the instrument memory. See “Loading an Optional Measurement Personality” on page 116.
2. Enter a license key number that activates the measurement personality. See “Installing a License Key” on page 117.

Adding additional measurement personalities requires purchasing a retrofit kit for the desired option. The retrofit kit contains the measurement personality firmware and a license key certificate. It documents the license key number that is specific for your option and instrument serial number.

Why Aren't All the Personality Options Loaded in Memory?

There are many measurement personality options available for use with this instrument. Some versions of instrument hardware may not have enough memory to accommodate all the options that you have ordered. If this is the case you will need to swap the applications in/out of memory, as needed. It may be possible to upgrade your hardware to have more memory. Contact your local sales/service office.

Available Measurement Personality Options

To order a measurement personality option you need the instrument model number, the host ID and the serial number.

Required Information:	Front Panel Key Path:
Model #: (Ex. E4406A)	
Host ID: _____	System, Show System
Instrument Serial Number: _____	System, Show System

NOTE

For PSA, the instrument must have Option B7J in order to use most of the measurement personality options. (cdmaOne, cdma2000, 1xEV-DO, W-CDMA, GSM, EDGE, NADC, PDC.)

Personality Options^a (for PSA series and E4406A)	Option	File Size (PSA Rev: A.04.00) (E4406A Rev: A.06.00)
cdmaOne measurement personality	BAC	2,000,000 Bytes
NADC measurement personalities (sold with PDC)	BAE	1,300,000 Bytes
PDC measurement personalities (sold with NADC)	BAE	1,400,000 Bytes
W-CDMA measurement personality	BAF	4,700,000 Bytes ^b
cdma2000 measurement personality	B78	4,000,000 Bytes ^b
1xEV-DO measurement personality	204	4,800,000 Bytes ^b
Shared measurement library ^c	n/a	1,400,000 Bytes
PSA only Options:		
Phase noise measurement personality	226	2,800,000 Bytes
Noise Figure measurement personality	219	3,000,000 Bytes
Basic measurement personality with digital demod hardware	B7J	Cannot be deleted
GSM (with EDGE) measurement personality	202	3,400,000 Bytes ^b
HP8566B/HP8568B Programming Code Compatibility ^d	266	650,000 Bytes
E4406A only Options:		
GSM measurement personality	BAH	2,500,000 Bytes
EDGE (with GSM) measurement personality ^e	202	3,400,000 Bytes
iDEN measurement personality	HN1	1,800,000 Bytes
Baseband I/Q Inputs	B7C	n/a (hardware only)

- a. Available as of the print date of this guide.
- b. Some PSA Series personality options use a shared measurement library. You have to add the memory requirements of this library to the value needed for the option. If you are loading multiple personalities that use this library, you only need to add this memory requirement once.
- c. The E4406A personality options use a shared measurement library. You have to add the memory requirements of this library to the value needed for any option.

Setting Up the Mode
Installing Optional Measurement Personalities

- d. This option is free and does not require a license key.
- e. For instruments that already have Option BAH licensed, order E4406AU Option 252 to add EDGE (with GSM).

Loading an Optional Measurement Personality

You must load the desired personality option into the instrument memory. Loading can be done from a firmware CD-ROM or the internet location. An automatic loading program comes with the files and runs from your PC.

NOTE

When you add a new option, or update an existing option, you will get the updated version of all your current options since they are reloaded simultaneously. This process may also require you to update the instrument core firmware so that it is compatible with the new option.

You may not be able to fit all of the available measurement personalities in instrument memory at the same time. You may need to delete an existing option file from memory and load the one you want. Use the automatic update program that is provided with the files.

The approximate memory requirements for the options are listed above. These numbers are worst case examples. Some options share components and libraries, therefore the total memory usage of multiple options may not be exactly equal to the combined total.

NOTE

For PSA: To facilitate mode switching, you must have some available memory (~500 kB) after loading all your optional measurement personalities. For example, if you have used up most of your free memory saving files of state and/or trace data, your mode switching times can increase to more than a minute.

For E4406A, you may want (or need) to add optional memory to load all the different measurement personalities that you want.

Required Information:	Key Path:
Instrument Memory: _____	System, File System (This key is grayed out.) The total amount of memory in your instrument will be the sum of the Used memory and the Free memory.

For E4406A, you can install an update version of core firmware and your licensed options using a LAN connection and your PC. The **Exit Main Firmware** key halts the operation of the instrument firmware so you can install an updated version. Instructions for loading future firmware updates are available from the following internet location:
<http://www.agilent.com/find/vsa/>

For PSA, you can install an updated version of firmware and your licensed options using a LAN connection and your PC. Instructions for loading future firmware updates are available from the following internet location: <http://www.agilent.com/find/psa/>

Installing a License Key

To install a license key number for the selected personality option, use the following procedure.

NOTE

You can also use this procedure to reinstall a license key number that has been deleted during an uninstall process, or lost due to a memory failure

For PSA:

1. Press **System, More, More, Licensing, Option** to access the alpha editor. Use this alpha editor to enter letters (upper-case), and the front-panel numeric keys to enter numbers for the option designation. You will validate your option entry in the active function area of the display. Then, press the **Enter** key.
2. Press **License Key** to enter the letters and digits of your license key. You will validate your license key entry in the active function area of the display. Then, press the **Enter** key.
3. Press the **Activate License** key.

For E4406A:

1. Press **System, More, More, Install, Choose Option** to access the alpha editor. Use this alpha editor to enter letters (upper-case), and the front-panel numeric keys to enter numbers for the option designation. You will validate your option entry in the active function area of the display. Then, press the **Done** key.

NOTE

Before you enter the license key for the EDGE Retrofit Option 252, you must already have entered the license key for the GSM Option BAH.

2. Press **License Key** to enter the letters and digits of your license key. You will validate your license key entry in the active function area of the display. Then, press the **Done** key.
3. Press the **Install Now** key. The message “New option keys become active after reboot.” will appear, along with the **Yes/No** menu: press the **Yes** key and cycle the instrument power off and then on to complete your installation process, or press the **No** key to cancel the installation process.

Viewing a License Key

Measurement personalities purchased with your instrument have been installed and activated at the factory before shipment. You will receive a **License Key** unique to every measurement personality purchased. The license key number is a hexadecimal number specific to your measurement personality, instrument serial number and host ID. It enables you to install, or reactivate that particular personality.

Use the following procedure to display the license key number unique to your personality option that is already installed in your instrument:

For PSA:

Press **System, More, More, Licensing, Show License**. The **System, Personalities** keys show you the license key if the option has been activated.

For E4406A:

Press **System, More, More, Install, Choose Option** to enter the letters/numbers for the option you want. You can see the key on the **License Key** softkey. Press the Done key.

NOTE

You will want to keep a copy of your license key number in a secure location. Press System, More, then Personality for PSA, or Show System for E4406A, and print out a copy of the display that shows the license numbers. If you should lose your license key number, call your nearest Agilent Technologies service or sales office for assistance.

Using the Delete License Key on PSA

This key will make the option unavailable for use, but will not delete it from memory. Write down the 12-digit license key number for the option before you delete it. If you want to use that measurement personality later, you will need the license key number to reactivate the personality firmware.

NOTE

Using the **Delete License** key does not remove the personality from the instrument memory, and does not free memory to be available to install another option. If you need to free memory to install another option, refer to the instructions for loading firmware updates located at the URL: <http://www.agilent.com/find/psa/>

1. Press **System, More, More, Licensing, Option**. Pressing the **Option** key will activate the alpha editor menu. Use the alpha editor to enter the letters (upper-case) and the front-panel numeric keyboard to enter the digits (if required) for the option, then press the **Enter** key. As you enter the option, you will see your entry in the active function area of the display.
2. Press **Delete License** to remove the license key from memory.

Using the Uninstall Key on E4406A

This key will make the option unavailable for use, but will not delete it from memory. The message “Application Not Licensed” will appear in the Status/Info bar at the bottom of the display. Record the 12-digit license key number for the option before you delete it. If you want to use that measurement personality later, you will need the license key number to reactivate the personality firmware.

NOTE

Using the **Uninstall** key does not remove the personality firmware from the instrument memory, and does not free memory to be available to install another option. If you need to free memory to install another option, refer to the instructions for loading firmware updates available at the URL: <http://www.agilent.com/find/vsa/>

1. Press **System, More(1 of 3), More(2 of 3), Uninstall, Choose Option** to access the alpha editor. Use this alpha editor to enter the letters (upper-case), and the front-panel numeric keys to enter the numbers (if required) for the installed option. You will validate your option entry in the active function area of the display. Then, press the **Done** key.
2. Pressing the **Uninstall Now** key will activate the **Yes/No** menu: press the **Yes** key to continue your uninstall process, or press the **No** key to cancel the uninstall process.
3. Cycle the instrument power off and then on to complete the uninstall process.

Setting Up the Mode
Installing Optional Measurement Personalities

4 Making Measurements

1xEV-DO Measurements

This chapter begins with instructions common to all measurements made by the Transmitter Tester, then details all 1xEV-DO measurements available by pressing the **MEASURE** key. For information specific to individual measurements refer to the sections at the page numbers below.

- “Making the Channel Power Measurement” on page 130
- “Making the Intermodulation Measurement” on page 135
- “Making the Power versus Time Measurement” on page 141
- “Making the Spurious Emissions and ACP Measurement” on page 150
- “Making the Occupied Bandwidth Measurement” on page 166
- “Making the Forward Link Code Domain Measurement” on page 170
- “Making the Reverse Link Code Domain Measurement” on page 181
- “Making the Forward Link Modulation Accuracy (Composite Rho) Measurement” on page 197
- “Making the Reverse Link Modulation Accuracy (Composite Rho) Measurement” on page 214
- “Making the QPSK EVM Measurement” on page 226
- “Making the Power Stat CCDF Measurement” on page 236
- “Making the Spectrum (Frequency Domain) Measurement” on page 241
- “Making the Waveform (Time Domain) Measurement” on page 254

All the measurements above are referred to as one-button measurements. When you press the key to select a measurement it will become active, using settings and displays unique to that measurement. Data acquisition will automatically begin when trigger requirements, if any, are met.

Preparing for Measurements

If you want to set the 1xEV-DO mode to a known, factory default state, press **Preset**. This will preset the mode setup and all of the measurements to the factory default parameters. You should often be able to make a measurement using these defaults.

NOTE

Pressing the **Preset** key does not switch instrument modes.

To preset only the parameter settings that are specific to the selected measurement, press **Meas Setup, More, Restore Meas Defaults**. This will reset the measurement setup parameters, for the currently selected measurement only, to the factory defaults.

Initial Setup

Before making a measurement, make sure the mode setup and frequency channel parameters are set to the desired settings. Refer to the sections [“Changing the Mode Setup” on page 71](#) and [“Changing the Frequency Channel” on page 77](#).

For PSA with Option 1DS Internal Preamplifier, see [“Configuring the Input Condition” on page 72](#) for details of **Int Preamp** and **Attenuator** operation.

Measurement Selection

The **MEASURE** front-panel key accesses the menu to select one of the following measurements:

- **Channel Power** - Press this key to make channel power measurements for BTS (Fwd) and MS (Rev) tests. This is the in-channel power measurement. The channel power graph is displayed in the graph window and both the absolute channel power and mean power spectral density are shown in the text window.
- **Intermod** - Press this key to make intermodulation products measurements for BTS (Fwd) tests. Three measurement modes are available as follows:
 - Auto - Automatically identifies one of two modes between two-tone or transmit intermodulation products.
 - Two-tone - Measurements are made assuming two signals present in the span are the two tone signals.
 - Transmit IM - Measurements are made assuming the lower frequency signal to be the modulated transmitted signal and the higher frequency signal to be the tone signal.

- **Power vs Time** - Press this key to make power versus time measurements for BTS (Fwd) tests. This is the time-captured burst power measurement. The time offsets and power mask levels up to 5 pairs are defaulted for quick applications according to the radio standard, however, these are also user-definable for specific measurement requirements. Choices of display portions for those burst signals include the whole burst waveform, rising and falling edge waveforms, rising edge waveform, and so forth.
- **Spurious Emissions & ACP** - Press this key to make adjacent channel power (ACP) measurements or spurious emissions measurements with frequency offsets and mask limits up to 5 pairs, for BTS (Fwd) tests. The **Meas Mode** key toggles the measurement function mode between **SEM** and **ACP**. The measurement mask is configurable with flat and sloped lines according to the radio system specifications. Spurious emissions measurements can be done with some restrictions from the upper frequency bandwidth by setting the measurement regions with **SEM** in **Meas Mode**.
- **Occupied BW** - Press this key to make occupied bandwidth measurements for BTS (Fwd) and MS (Rev) tests. The frequency bandwidth that contains 100.0% of the total power is measured first, and then 99.0% of the frequency bandwidth is calculated as the measurement result.
- **Code Domain** - Press this key to make code domain power (CDP) measurements. The amount of power in each code channel is displayed.

For BTS tests by setting **Device** to **BTS (Fwd)**, the following windows are available:

- Power graph and metrics to show the I and Q code domain power versus Walsh code and the summary data
- I/Q polar and power graphs to show the code domain power, I/Q symbol polar vector for the specified Walsh code, and its chip power

For MS tests by setting **Device** to **MS (Rev)**, the following windows are available:

- Power graph and metrics to show the code domain power versus Walsh code and the summary data
- I/Q error quad view with the magnitude error versus symbols, phase error versus symbols, and error vector magnitude versus symbols graphs, and the summary data in the text window
- Code domain quad view with inclusion of the I and Q power versus Walsh code, symbol power for the specified Walsh code, I/Q symbol polar vector graphs with a text window for the summary data

- Demodulated bits to show the I and Q power graph versus Walsh code, symbol power for the specified Walsh code, and the demodulated bits stream of the specified symbol power
- **Mod Accuracy (Composite Rho)** - Press this key to make modulation accuracy (composite rho) measurements. The input signal should contain the Pilot channel. This is essentially a code domain power measurement with more than one active channel.

For BTS tests by setting **Device** to **BTS (Fwd)**, the following windows are available:

- Polar graph of the I/Q demodulated signals and the summary data
- Result metrics table for the measured channels, rho, EVM, errors for magnitude, phase, and frequency, the I/Q origin offset, pilot offset, and the number of active channels for pilot, MAC, and data
- I/Q error quad view with the magnitude error versus chips, phase error versus chips, and error vector magnitude versus chips graphs, and the summary data in the text window
- I/Q measured quad view with inclusion of the I and Q power versus chips, I/Q vector absolute power versus chips, and I/Q measured polar graphs with a text window for the mean power level
- Power, timing, and phase table to list the measurement results for Code, Power (dB), Timing (ns), and Phase (rad).

For MS tests by setting **Device** to **MS (Rev)**, the following windows are available:

- Polar graph of the I/Q demodulated signals and the summary data
- Result metrics table for the measured channels, rho, EVM, errors for magnitude, phase, and frequency, the I/Q origin offset, pilot offset, and the code domain power levels of active channels for pilot, RRI, ACK, DRC, and data
- I/Q error quad view with the magnitude error versus chips, phase error versus chips, and error vector magnitude versus chips graphs, and the summary data in the text window
- **QPSK EVM** - Press this key to make QPSK error vector magnitude (EVM) measurements for BTS (Fwd) tests. The following windows are available:
 - Polar vector graph of the I/Q demodulated signals and the summary data
 - Polar constellation graph of the I/Q demodulated signals and the summary data

- I/Q error quad view with the magnitude error versus chips, phase error versus chips, and EVM versus chips graphs, and the summary data
- **Power Stat CCDF** - Press this key to make power statistics, Complementary Cumulative Distribution Function (CCDF) measurements for BTS (Fwd) and MS (Rev) tests. This is helpful to observe the time domain characteristics of a spread spectrum signal that can significantly affect the ACPR measurement results for a given UUT.
- **Spectrum (Freq Domain)** - Press this key to make frequency domain spectrum measurements for BTS (Fwd) and MS (Rev) tests. The following windows are available:
 - Spectrum graph with the semi-log graticules and I/Q waveform graph with the linear graticules
 - Linear spectrum graph with the linear graticules (E4406A)
 - I and Q waveform graphs with the linear graticules (E4406A)
 - I/Q polar graph of the demodulated I/Q signals with the linear graticules (E4406A)
- **Waveform (Time Domain)** - Press this key to make time domain waveform measurements for BTS (Fwd) and MS (Rev) tests. The following windows are available:
 - RF signal envelope graph with semi-log graticules and summary data
 - I/Q waveform graph and summary data
 - I/Q polar graph of the demodulated I/Q signals with the linear graticules (E4406A)

Measurement Control

The **Meas Control** front-panel key accesses the menu to control processes that affect the running of the current measurement.

- **Restart** - Press this key to repeat the current measurement from the beginning, while retaining the current measurement settings. When pressed, the scale coupling function is activated for an appropriate display to the current input signal level. This is equivalent to the **Restart** front-panel key.
- **Measure** - Press this key (not to be confused with the **MEASURE** front-panel key which has a different function) to toggle the measurement state between **Single** and **Cont** (continuous). When set to **Single**, the measurement will continue until it has reached the specified number of averages set by the average counter. When set to **Cont**, the measurement will run continuously and execute averaging

according to the current average mode, either repeat or exponential. The default setting is **Cont** for most measurements, but the Code Domain and Power Stat CCDF measurements have **Single** as the default.

- **Pause** - Press this key to pause the current measurement until you reactivate the measurement. Once toggled, the label of the **Pause** key changes to read **Resume**. The **Resume** key, once pressed, continues the active measurement from the point at which it was paused.

Measurement Setup

The **Meas Setup** key accesses the features that enable you to adjust parameters of the current measurement, such as span and resolution bandwidth, according to the measurement function. You will also use the **Meas Setup** menu to access the **Average**, **Limit Test**, **Advanced** and other feature menus.

The following measure setup features can be used with many or all measurements:

- **Restore Meas Defaults** - Allows you to preset only the settings that are specific to the selected measurement by pressing **Meas Setup**, **More**, **Restore Meas Defaults**. This will set the measure setup parameters, for the currently selected measurement only, to the factory defaults.

Averaging

Selecting one of the averaging keys in the **Meas Setup** menu will allow you to modify the average number and averaging mode you use for the currently selected measurement. For spectrum (frequency domain) and waveform (time domain) measurements the **Average** key activates the following menu.

- **Avg Number** - Allows you to change the number of N averages to be made.
- **Avg Mode** - Allows you to toggle the averaging mode between **Exp** (exponential) and **Repeat**. This selection only effects on the averaging result after the number of N averages is reached. The N is set using the **Avg Number** key.
 - **Normal averaging**: Normal (linear) averaging is always used until the specified number of N averages is reached. When the **Measure** key under **Meas Control** is set to **Single**, data acquisition is stopped when the number of N averages is reached, thus **Avg Mode** has no effect in the single measurement mode.
 - **Exponential averaging**: When **Measure** is set to **Cont**, data acquisition will continue indefinitely. Exponential averaging is used with a weighting factor of N (the displayed count of averages stops at N). Exponential averaging weights new data more

heavily than old data, which allows tracking of slow-changing signals. The weighting factor N is set using the **Avg Number** key.

— **Repeat averaging:** When **Measure** is set to **Cont**, data acquisition will continue indefinitely. After the number of N averages is reached, all previous result data is cleared and the average count displayed is set back to 1. This is equivalent to being in **Measure Single** and pressing the **Restart** key each time the single measurement finishes.

- **Avg Type** - Allows you to access the menu of the following average types only for making spectrum (frequency domain) and waveform (time domain) measurements:

Pwr Avg (RMS) - Executes the true power averaging which is equivalent to taking the rms of the voltage. This is the most accurate type.

Log-Pwr Avg (Video) - Simulates the traditional spectrum analyzer type of averaging by calculating the log of the power.

Voltage Avg - Executes the voltage averaging.

Maximum - Executes the maximum voltage averaging by capturing peak data.

Minimum - Executes the minimum voltage averaging.

Selecting a Trigger Source

Changing the selection in the **Trig Source** menu alters the trigger source for the selected measurement only. Not all of the selections are always available for all measurements. Also, some 1xEV-DO measurements do not require a trigger. Choose one of the following trigger sources depending on the selected measurement:

NOTE

The **RF Burst**, **Video (Envlp)**, **Ext Front**, and **Ext Rear** keys found under the **Trigger** menu enable you to change the default settings of the delay, level and slope for each of these trigger sources.

- **Free Run (Immediate)** - A trigger occurs at the time the data is requested, completely asynchronous with the RF or IF signal.
- **Video (Envlp)** - An internal IF envelope trigger that occurs at the absolute threshold level of the IF signal level.
- **RF Burst (Wideband)** - An internal wideband RF burst trigger that has the automatic level control for burst signals. It triggers at the level that is set relative to the peak RF signal (12 MHz bandwidth) input level.
- **Ext Front** - Activates the front-panel external trigger input (**EXT TRIGGER INPUT**) port. The external signal must be between -5.00 V and $+5.00$ V with 1 or 10 mV resolution.

- **Ext Rear** - Activates the rear-panel external trigger input (**TRIGGER IN**) port. The external signal must be between -5.00 V and $+5.00\text{ V}$ with 1 or 10 mV resolution.
- **Frame** - Uses the internal frame clock to generate a trigger signal. The clock parameters are controlled under the **Mode Setup** key or the measurement firmware, but not both. Refer to the specific measurement section for details.
- **Line** - Sets the trigger to the internal line mode. Sweep triggers occur at intervals synchronous to the line frequency. Refer to the specific measurement section for details.

Using the Trigger Outputs

The rear panel **TRIGGER 1 OUT** and **TRIGGER 2 OUT** connectors are coupled to the selected trigger source. These trigger outputs are always on at the rising edge with a pulse width of at least $1\ \mu\text{s}$.

Making the Channel Power Measurement

Purpose

The Channel Power measurement is a common test used in the wireless industry to measure the total transmitted power of a radio within a defined frequency channel. This procedure measures the total power within the defined channel for 1xEV-DO. This measurement is applied to design, characterize, evaluate, and verify transmitters and their components or devices for base stations and mobile stations.

NOTE For 1xEV-DO, depending on the installed measurement personality revision and measurement selection, the test device is fixed to base stations.

Measurement Method

The Channel Power measurement reports the total transmitted power within the channel bandwidth, 1.23000 MHz for the 1xEV-DO mode. The measurement acquires a number of points representing the input signal in the time domain. It transforms this information into the frequency domain using FFT and then calculates the channel power. The effective resolution bandwidth of the frequency domain trace is proportional to the number of points acquired for FFT. The fastest FFT process is achieved using a number of acquired points that is a power of 2 (for example: 64, 128, 512).

Since the measurement is optimized for speed and accuracy, you are permitted to change only the number of acquired data points in powers of 2, not the actual resolution bandwidth which is shown in gray. However, if absolute sweep time is required, it can be changed to the user's specific value at the expense of reduced speed. At no time will both sweep time and data points be set to manual because of conflicting parameter settings. This flexibility is available through the **Advanced** menu of the channel power measurement.

To improve repeatability, you can increase either the number of averages or the number of data points with longer time record length. The channel power graph is shown in the graph window, while the absolute channel power in dBm and the mean power spectral density in dBm/Hz are shown in the text window.

Making the Measurement

NOTE The factory default settings provide a good starting point. You may want to change some of the settings. Press **Meas Setup, More, Restore**

Meas Defaults at any time to return all parameters for the current measurement to their default settings.

Select the desired center frequency as described in “Changing the Frequency Channel”.

Press **MEASURE, Channel Power** to immediately make a channel power measurement.

To change any of the measurement parameters from the factory default values, refer to the “Changing the Measurement Setup” section for this measurement.

Results

The following figure shows an example result of Channel Power measurement result. The channel power graph is shown in the graph window. The absolute channel power and its mean power spectral density are shown in the text window.

Figure 4-1

Channel Power Measurement

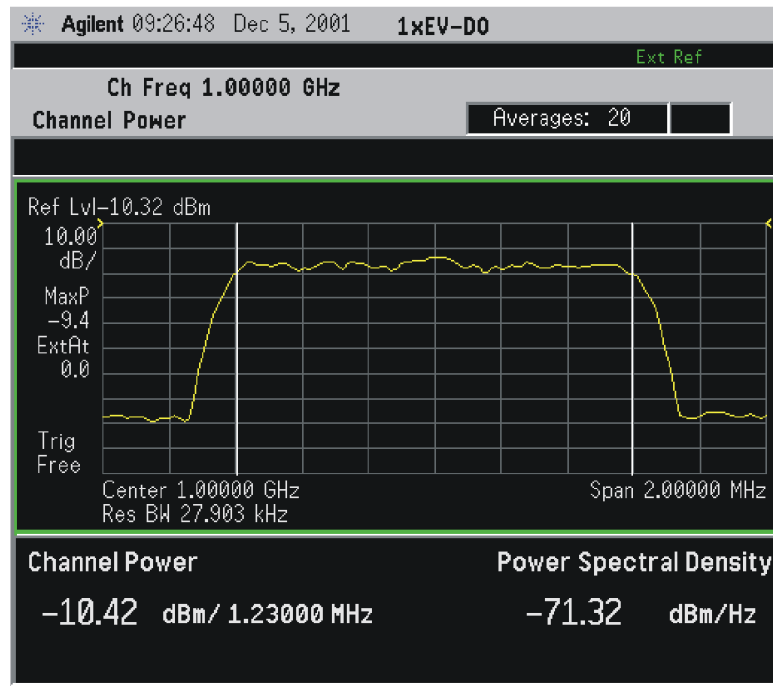

*Meas Setup: Factory default settings

*Input signal: -10.00 dBm, Pilot channel, 1xEV-DO

Changing the Measurement Setup

The next table shows the factory default settings for channel power measurements.

NOTE Parameters under the **Advanced** key seldom need to be changed. Any changes from the factory default values may result in invalid measurement data.

Table 4-1 Channel Power Measurement Defaults

Measurement Parameter	Factory Default Condition
Meas Setup:	
Avg Number	20; On
Avg Mode	Repeat
Integ BW ^a	1.23000 MHz
Chan Power Span ^a	2.00000 MHz
Advanced	
Sweep Time	68.0µs; Auto
Data Points	512; Auto
Res BW (grayed out)	27.903 kHz (grayed out)
Trig Source	Free Run (Immediate)

a. The Integ BW setting proportionally changes the Chan Power Span setting up to 10 MHz.

Make sure the **Channel Power** measurement is selected under the **MEASURE** menu. The **Meas Setup** key accesses the menu which allows you to modify the average number and average mode for this measurement.

In addition, the following parameters can be changed according to your measurement requirements:

- **Integ BW** - Allows you to specify the integration bandwidth in which the power is measured. The range is 1.000 kHz to 10.0000 MHz with 1 Hz resolution. Since **Integ BW** is coupled to **Chan Power Span** in the factory default condition, if you change the integration bandwidth setting, the channel power span setting changes by a proportional amount, 1.626 times the integration bandwidth, until a limit value is reached.
- **Chan Power Span** - Allows you to set the frequency span for the channel power measurement. The range is 1.000 kHz to 10.0000 MHz with 1 Hz resolution. This span is used for the current integration bandwidth setting. Since **Chan Power Span** is coupled to **Integ BW** in the factory default condition, if you change the integration bandwidth setting, the channel power span setting changes by a proportional amount, 1.626 times the integration

bandwidth, until a limit value is reached. However, the channel power span can be individually set.

- **Advanced** - Allows you to access the following menu to modify the channel power measurement parameters:
 - **Sweep Time** - Allows you to manually change the sweep time and also to toggle the sweep time control between **Auto** and **Man** (manual). The range is 1.0 μ s to 50.00 ms with 1 μ s resolution. If set to **Auto**, the sweep time derived from the data point setting is shown on this key regardless of the manual entry range.
 - **Data Points** - Allows you to select the number of data points and also to toggle the data point control between **Auto** and **Man** (manual). The range is 64 to 65536 with the acceptable entry in powers of 2 (for example: 64, 128, 512). If set to **Auto**, the optimum number of points is determined for the fastest measurement time with acceptable repeatability. The minimum number of points that could be used is determined by the sweep time and the sampling rate. You can increase the length of the measured time record (capture more of the burst) by increasing the number of points, but the measurement will take longer.
 - **Res BW** - Shows information on the resolution bandwidth derived from the sweep time. This key is always grayed out.
 - **Trig Source** - Allows you to choose a trigger source from **Free Run (Immediate)**, **Ext Front**, **Ext Rear**, **Frame**,.

Changing the Display

The **AMPLITUDE Y Scale** key accesses the menu to set the desired vertical scale and associated settings:

- **Scale/Div** - Allows you to enter a numeric value to change the vertical display sensitivity. The range is 0.10 to 20.00 dB with 0.01 dB resolution. The default setting is 10.00 dB. However, since the **Scale Coupling** default is **On**, this value is automatically determined by the measurement result. When you set a value manually, **Scale Coupling** automatically changes to **Off**.
- **Ref Value** - Allows you to set the absolute power reference value ranging from -250.00 to 250.00 dBm with 0.01 dB resolution. The default setting is 10.00 dBm. However, since the **Scale Coupling** default is **On**, this value is automatically determined by the measurement result. When you set a value manually, **Scale Coupling** automatically changes to **Off**.
- **Ref Position** - Allows you to set the display reference position to either **Top**, **Ctr** (center), or **Bot** (bottom). The default setting is **Top**.
- **Scale Coupling** - Allows you to toggle the scale coupling function between **On** and **Off**. The default setting is **On**. Upon pressing the

Restart front-panel key or **Restart** softkey under the **Meas Control** menu, the scale coupling function automatically determines the scale per division and reference values based on the measurement results. When you set a value to either **Scale/Div** or **Ref Value** manually, **Scale Coupling** automatically changes to **Off**.

Using the Marker

The **Marker** key is not available for this measurement function.

Troubleshooting Hints

If an external attenuator is used, be sure to use the **Ext RF Atten** key to include the attenuation value in the displayed measurement result.

The channel power measurement, along with the adjacent channel power ratio measurement and spectrum measurements, can reveal the effects of degraded or defective parts in the transmitter section of the UUT. The following are areas of concern which can contribute to performance degradation:

- DC power supply control of the transmitter power amplifier, RF power control of the pre-power amplifier stage, and/or I/Q control of the baseband stage.
- Gain and output power levels of the power amplifier, caused by degraded gain control and/or increased distortion.
- Amplifier linearity.

Making the Intermodulation Measurement

Purpose

The 1xEV-DO standard defines transmit intermodulation as a measure of transmitter quality. Intermodulation products are generated by non-linear components or devices in equipment where two signals, one desired and another undesired, are present. Transmit intermodulation is a measure of a transmitter's ability to inhibit the generation of the intermodulation products.

Measurement Method

The intermodulation measurement measures the third-order and fifth-order intermodulation products caused by the wanted signal and the interfering signal. These intermodulation products are generated by the nonlinear devices or circuits in a transmitter. The measured results are evaluated as a ratio, relative to the carrier power.

There are two types of intermodulation:

- Two-tone - Measurements are made assuming two CW signals to be the tone signals.
- Transmit IM - Measurements are made assuming that one signal is the modulated transmitting signal and another is the CW signal.

This measurement automatically identifies either two-tone intermodulation mode or transmit intermodulation mode at the start of measurements. The fundamental signals, lower and upper, are automatically searched every sweep to calculate the proper results. When a measurement starts, the highest two peaks at frequency f_0 and f_1 are searched within a given span. Based on these frequencies, the frequencies associated with the possible third-order and fifth-order intermodulation products are calculated. The power bandwidth is checked to determine if the mode is two-tone intermodulation or transmit intermodulation.

The results are displayed both as relative power in dBc, and as absolute power in dBm. For transmit intermodulation products, the result is also shown as the power spectral density in dBm/MHz.

Making the Measurement

The default settings provide a 1xEV-DO compliant measurement. For special requirements, you may need to change some of the settings. Press **Meas Setup**, **More**, **Restore Meas Defaults** at any time to return all parameters for the current measurement to the factory default settings.

Select the desired center frequency as described in “Changing the Frequency Channel” on page 77.

Press **MEASURE**, **Intermod** (Intermodulation) to immediately make an intermodulation measurement. This measurement is applicable only for BTS (Fwd) tests.

To change any of the measurement parameters from the factory default values, refer to “Changing the Measurement Setup” on page 137.

Results

The following figure shows an example result of Intermodulation measurements in the graph window. The absolute power levels, relative power levels, and power spectral density levels on both sides of the reference signal are displayed in the text window.

Figure 4-2

Intermodulation Measurement - Transmit IM Mode View

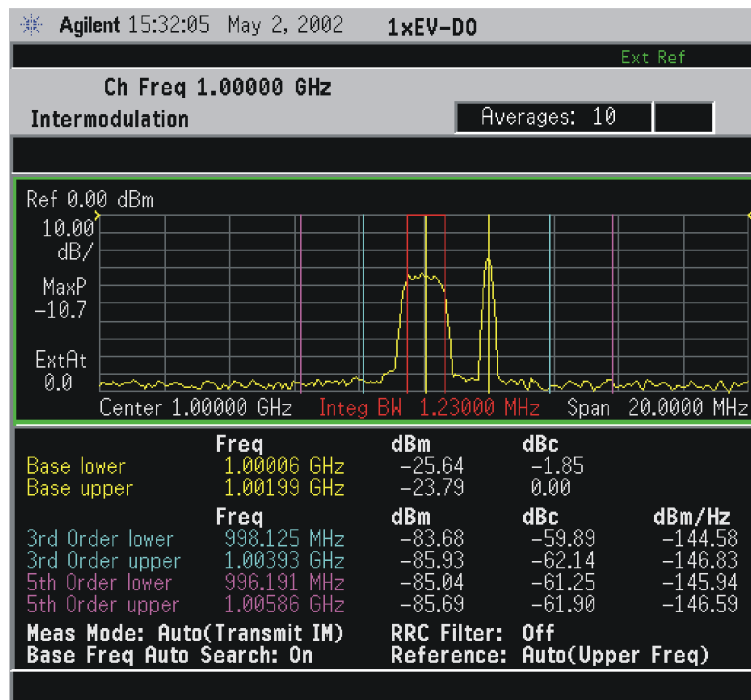

*Meas Setup: Factory default settings

*Input signal: (1) -10.00 dBm, 1.000 GHz, Pilot channel, 1xEV-DO
 (2) -10.00 dBm, 1.005 GHz, CW

Changing the Measurement Setup

This table shows the factory default settings for intermodulation measurements.

Table 4-2 Intermodulation Measurement Defaults

Measurement Parameter	Factory Default Condition
Display: IM Prod Ref	On
Meas Setup:	
Avg Number	10; On
Avg Mode	Repeat
Meas Mode	Two-tone, Transmit IM, or -----; Auto
Reference	Lower Freq or Upper Freq; Auto
Span	20.0000 MHz
Res BW	140.000 kHz; Auto
Base Freq Auto Search	On
Base Freq	(not available as Base Freq Auto Search is set to On)
Advanced	
Integ BW	1.23000 MHz

Make sure the Intermod measurement is selected under the MEASURE menu. The **Meas Setup** key accesses the menu which allows you to modify the average number and average mode for this measurement as described in “[Measurement Setup](#)” on page 127.

In addition, the following parameters can be modified according to your measurement requirements:

- **Meas Mode** - Allows you to specify one of the following measurement modes:
 - **Auto** - Automatically identifies whether the intermodulation is caused by the two-tone or transmit intermodulation signals and that mode is labeled in the middle line of the **Meas Mode** key. If appropriate signals are not identified, “-----” is shown instead.
 - **Two-tone** - Measures the two-tone intermodulation products.
 - **Transmit IM** - Measures the transmit intermodulation products.
- **Reference** - Allows you to access the selection menu for the reference

channel:

- **Auto** - Select this to set the reference channel automatically to the highest level signal in two base frequency signals.
- **Lower Freq** - Select this to set the reference channel to the base lower frequency signal.
- **Upper Freq** - Select this to set the reference channel to the base upper frequency signal.
- **Average** - Select this to set the reference channel to the average frequency signals, $(\text{base lower frequency signal} + \text{base upper frequency signal})/2$.
- **Span** - Allows you to specify the frequency span in which intermodulation products are measured. The range is 100.000 kHz to 100.000 MHz with 1 Hz resolution.
- **Res BW** - Allows you to specify the resolution bandwidth in which intermodulation products are measured, and to toggle this function between **Auto** and **Man**. If set to **Auto**, the resolution bandwidth is automatically set according to the frequency span. The range is 100.0 Hz to 300.000 kHz with 1 Hz resolution.
- **Base Freq Auto Search** - Allows you to toggle the base frequency auto search function between **On** and **Off**. If set to **On**, the base frequency is automatically searched for.
- **Base Freq** - Allows you to specify the base frequency values with the followings items if **Base Freq Auto Search** is set to **Off**:
 - **Lower Freq (f0)** - Accepts a frequency value for the base lower frequency signal (f0).
 - **Upper Freq (f1)** - Accepts a frequency value for the base upper frequency signal (f1).
 - **Delta Freq (f1-f0)** - Automatically shows the difference between the base lower and base upper frequencies.
- **Advanced** - Allows you to access the menu to set the following items:
 - **Integ BW** - Allows you to specify the integration bandwidth ranging from 100.0 kHz to 5.000 MHz.

Changing the View

The **View/Trace** key is not available for this measurement.

Changing the Display

When the Spectrum graph window is selected, the **AMPLITUDE Y Scale** key accesses the menu to set the desired measurement scale and associated parameters:

- **Scale/Div** - Allows you to enter a numeric value to change the vertical display sensitivity. The range is 0.10 to 20.00 dB with 0.01 dB resolution. The default setting is 10.00 dB. However, since the **Scale Coupling** default is **On**, this value is automatically determined by the measurement result. When you set a value manually, **Scale Coupling** automatically changes to **Off**.
- **Ref Value** - Allows you to set the absolute power reference value ranging from -250.00 to 250.00 dBm with 0.01 dB resolution. The default setting is 10.00 dBm. However, since the **Scale Coupling** default is **On**, this value is automatically determined by the measurement result. When you set a value manually, **Scale Coupling** automatically changes to **Off**.
- **Ref Position** - Allows you to set the reference position to either **Top**, **Ctr** (center), or **Bot** (bottom). The default setting is **Top**.
- **Scale Coupling** - Allows you to toggle the scale coupling function between **On** and **Off**. The default setting is **On**. Upon pressing the **Restart** front-panel key or **Restart** softkey under the **Meas Control** menu, the scale coupling function automatically determines the scale per division and reference values based on the measurement results. When you set a value to either **Scale/Div** or **Ref Value** manually, **Scale Coupling** automatically changes to **Off**.

The **Display** key also accesses the menu to control the marker lines on the display as follows:

- **IM Prod Lines** - Allows you to toggle the intermodulation product lines display function between **On** and **Off**. If set to **On**, two pair of dual vertical lines with the integration bandwidth are shown on the third-order or fifth-order intermodulation products display.

Using the Markers

The **Marker** front-panel key accesses the menu to configure the markers.

- **Select 1 2 3 4** - Allows you to activate up to four markers with the corresponding numbers, respectively. The selected number is underlined and its function is defined by pressing the **Function** key. The default is 1.
- **Normal** - Allows you to activate the selected marker to read the time position and amplitude of the marker on the Signal envelope trace, for example. Marker position is controlled by the **RPG** knob.
- **Delta** - Allows you to read the differences in time positions and amplitudes between the selected marker and the next.
- **Function** - Allows you to define the selected marker function to be **Band Power**, **Noise**, or **Off**. The default is **Off**. For measuring **Band Power**, you need to place the **Normal** marker and then place the **Delta** marker.

- **Trace** - Allows you to place the selected marker on the **Spectrum** trace.
- **Off** - Allows you to turn off the selected marker.
- **Shape Diamond** - Allows you to access the menu to define the selected marker shape to be **Diamond**, **Line**, **Square**, or **Cross**. The default is **Diamond**.
- **Marker All Off** - Allows you to turn off all of the markers.

The front-panel **Search** key performs a peak search when pressed. A marker will automatically be activated at the highest peak.

Troubleshooting Hints

Intermodulation distortion (IM) measurements can reveal the presence of degraded or defective parts in the transmitter section of the UUT. The following are examples of problems which, once indicated by IM testing, may require further attention:

- Faulty DC power supply control of the transmitter power amplifier.
- RF power controller of the pre-power amplifier stage.
- I/Q control of the baseband stage.
- Reduction in the gain and output power level of the amplifier due to a degraded gain control and/or increased distortion.
- Degradation of amplifier linearity and other performance characteristics.

Power amplifiers are one of the final stage elements of a base or mobile transmitter and play a critical part in meeting the important power and spectral efficiency specifications. Measuring the spectral response of these amplifiers to complex wideband signals is crucial to linking amplifier linearity and other performance characteristics to the stringent system specifications.

Making the Power versus Time Measurement

Purpose

A 1xEV-DO cellular system utilizes a variable rate voice coder in order to provide the maximum system capacity. According to the activity in the voice channel the codec varies the data rate. If the voice codec drops below the full rate, 9600 bps for instance, a 1xEV-DO mobile bursts its output power on and off proportionally to the data rate reduction. At a half rate, a mobile transmits 50% of the time, and at one eighth rate, it transmits 12.5% of the time. To prevent the interference caused by bursting the RF carrier, the associated standard specifies a power versus time template to which a mobile must conform.

This template defines the burst length, the rising and falling edges, the masks for regions of power on and power off.

Measurement Method

As a time domain data acquisition, one burst is captured with a trigger. The rising and falling edges are detected at the crossing points with the burst search threshold level. The burst center point in time is determined, and then the required masks are aligned in time with the center point. To make a precise slope detection, its threshold level and detection interval techniques are incorporated to extract only steep enough slopes out from the noise-like signals.

Making the Measurement

NOTE

The factory default settings provide a good starting point. For special requirements, you may want to change some of the settings. Press **Meas Setup, More, Restore Meas Defaults** at any time to return all parameters for the current measurement to their default settings.

Select the desired center frequency as described in [“Changing the Frequency Channel” on page 77](#).

Press **MEASURE, Power vs Time** to immediately make a power versus time measurement. This measurement is applicable only for BTS (Fwd) tests.

To change any of the measurement parameters from the factory default values, refer to [“Changing the Measurement Setup” on page 142](#).

Results

The following figure shows an example result of Power vs Time (RF Envelope) measurements in the graph window. The absolute power

levels of the mean transmit power, minimum and maximum power points and some time data are shown in text window.

Figure 4-3 Power vs Time Measurement - Idle Slot Type View

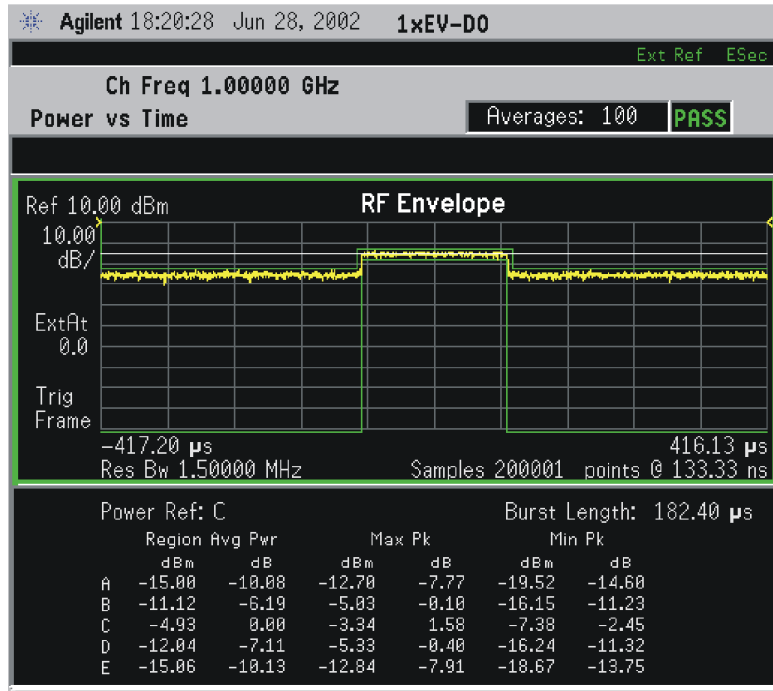

*Tester: Factory default settings

*Input signal: -10.00 dBm, Idle slot, 1xEV-DO

Changing the Measurement Setup

This table shows the factory default settings for power versus time measurements.

Table 4-3 Power versus Time Measurement Defaults

Measurement Parameter	Factory Default Condition
View/Trace	Burst
Avg Bursts	100; On
Avg Mode	Repeat
Avg Type	Pwr Avg (RMS)
Slot Type	Idle Slot (Pilot + MAC)
Trig Source	Frame
Region/Limits:	

Table 4-3 Power versus Time Measurement Defaults

Measurement Parameter	Factory Default Condition
Region	A
Offset Start	-416.67 μ s
Offset Stop	-97.33 μ s
Interval	319.34 μ s
Upper Mask	-7.00 dB; On
Lower Mask	-100.00 dB; Off
Power Reference	Region C
Time Reference	Burst Center
Burst Search Threshold	-10.00 dB
Advanced	
RBW Filter	Flat
Res BW	1.500 MHz
Burst Slope Threshold	2.0 dB/ μ s
Burst Slope Detect Intvl	2.0 chips (interpolated slope)
Time Ref Offset	0 s

Making Measurements

Make sure the **Power vs Time** measurement is selected under the **MEASURE** menu. The **Meas Setup** key accesses the menu which allows you to modify the average bursts, average mode and trigger sources for this measurement as described in the [“Measurement Setup” on page 127](#).

In addition, the following parameters can be modified according to your measurement requirements:

- **Avg Type** - Allows you to access the menu of the following average types:
 - **Pwr Avg (RMS)** - Executes the true power averaging which is equivalent to taking the rms of the voltage. This is the most accurate type.
 - **Log-Pwr Avg (Video)** - Simulates the traditional spectrum analyzer type of averaging by calculating the log of the power.
 - **Voltage Avg** - Executes the voltage averaging.
 - **Maximum** - Executes the maximum voltage averaging by capturing peak data.
 - **Minimum** - Executes the minimum voltage averaging.
- **Slot Type** - Allows you to access the menu to select either of the following slots:

- **Idle Slot** - Allows you to measure the burst power waveform of the Pilot and MAC channels with the masks in all regions.
- **Active Slot** - Allows you to measure the total power waveform of Pilot, Mac, and Data channels with the upper and lower masks for one half slot interval of 1024 chips or 833.3 ms.
- **Region/Limits** - Allows you to access the menu to change the following parameters for offset time settings and power level masks:
 - **Region** - Allows you to access the memory selection menu from **A** to **E** to store 5 sets of values for **Offset Start**, **Offset Stop**, **Interval**, **Upper Mask**, **Lower Mask**, and **Power Ref**, respectively. Only one memory selection at a time (A, B, C, D, or E) is shown on this key. This key is not available if **Slot Type** is set to **Active Slot**.
 - **Offset Start** - Allows you to enter a value for the offset start of a region. The range is $-1000.00 \mu\text{s}$ to $+1000.00 \mu\text{s}$, or -1000 chips to $+1000$ chips. While this key is activated, enter an offset value from the numeric keypad by terminating with one of the unit keys shown. One offset value selected in the **Region** menu is shown on this key. This key is not available if **Slot Type** is set to **Active Slot**.
 - **Offset Stop** - Allows you to enter a value for the offset stop of a region. The range is $-1000.00 \mu\text{s}$ to $+1000.00 \mu\text{s}$, or -1000 chips to $+1000$ chips. While this key is activated, enter an offset value from the numeric keypad by terminating with one of the unit keys shown. When you set a value to **Interval**, **Offset Stop** is automatically determined based on the offset start and interval values, as **Offset Stop** and **Interval** are coupled each other. One offset value selected in the **Region** menu is shown on this key. This key is not available if **Slot Type** is set to **Active Slot**.
 - **Interval** - Allows you to enter an interval value between Offset Start and Offset Stop. The range is $-1000.00 \mu\text{s}$ to $+1000.00 \mu\text{s}$, or -1000 to $+1000$ chips. While this key is activated, enter an interval value from the numeric keypad by terminating with one of the unit keys shown.
 - **Upper Mask** - Allows you to enter a relative limit value for the upper mask, and to toggle the mask function between **On** and **Off**. The range is from -100.00 to $+50.00$ dB with 0.01 dB resolution.
 - **Lower Mask** - Allows you to enter a relative limit value for the lower mask, and to toggle the mask function between **On** and **Off**. The range is from -100.00 to $+50.00$ dBm with 0.01 dB resolution.
 - **Power Ref** - Allows you to toggle the power reference function between **On** and **Off**. You can set only one region out of 5 regions to **On**, and the rest of regions are automatically set to **Off**. This key is not available if **Slot Type** is set to **Active Slot**.
- **Power Reference** - Allows you to access the following menu to select

one of the power references to make measurements:

- **Region A to Region E** - Allows you to set the power reference to **Region A** through **Region E** to make relative power measurements.
- **Time Reference** - Allows you to access the following menu to select one of the time references to make measurements:
 - **Burst Rise** - Allows you to set the time reference to the rising edge of bursts.
 - **Burst Center** - Allows you to set the time reference to the center of burst length.
 - **Trigger** - Allows you to set the time reference to the trigger point.
- **Burst Search Threshold** - Allows you to set a value of relative power level from the averaged power-on reference. This value is used to determine the rising and falling edges. The range is from -100.00 to 0.00 dB.
- **Advanced** - Allows you to access the menu to set the following parameters:
 - **RBW Filter** - Allows you to toggle the filter function between **Gaussian** and **Flat**.
 - **Res BW** - Allows you to enter a value for the resolution bandwidth. The range is from 1.000 kHz to 7.500 MHz.
 - **Burst Slope Threshold** - Allows you to enter a value for the power level change in μs . This will assure you to detect steep enough slopes in conjunction with **Burst Slope Detect Intvl**. The range is from 0.1 dB/ μs to 10.0 dB/ μs .
 - **Burst Slope Detect Intvl** - Allows you to enter a number of chips within which the slope power level changes are integrated for mathematically deriving an averaged slope. If this slope is steeper than the slope threshold level, this slope is detected as the valid one. If not, this slope is not used to detect an edge. The range is from 0.5 chips to 3.0 chips in 0.1 chips.
 - **Time Ref Offset** - Allows you to enter a value for the time reference offset. This value is used to make a fine timing adjustment from the time reference identified. The range is from -10.0 ms to +10.00 ms.

Changing the View

The **View/Trace** key accesses the menu to select one of the following view types. If **Slot Type** is set to **Active Slot**, other view selection keys but **Burst** is not available.

Making Measurements
 Making the Power versus Time Measurement

- **Burst** - Displays the whole burst waveform through out the all regions.

Figure 4-4 Power vs. Time Measurement - Burst View

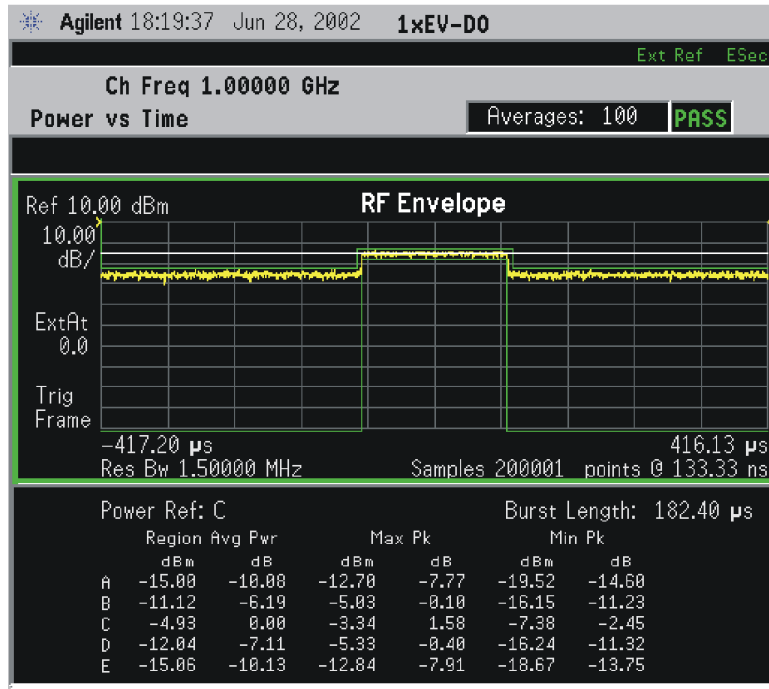

*Tester: View/Trace = Burst,
 Other factory default settings

*Input signal: -10.00 dBm, Idle slot, 1xEV-DO

- **Rise & Fall** - Displays both the rising edge and the falling edge regions expanded in the horizontal scale.

Figure 4-5

Power vs. Time Measurement - Rise & Fall View

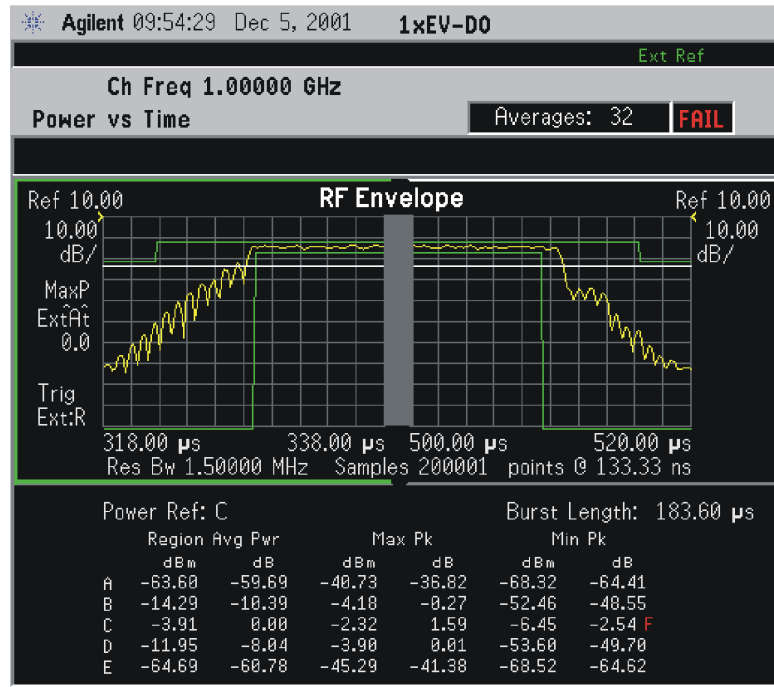

Making Measurements

*Tester: View/Trace = Rise & Fall,
 Others = Factory default settings

*Input signal: -10.00 dBm, Idle slot, 1xEV-DO

While in this view, you can change the vertical scale by pressing the **AMPLITUDE Y Scale** key. You can also activate or deactivate the reference bandwidth markers by pressing the **Display** key.

- **Region A through Region E** - Displays each region from A through E in the full horizontal scale.

Changing the Display

The **Display** key accesses the menu to control the lines as follows:

- **Limit Mask** - Toggles the limit mask display function between **On** and **Off**. If set to **On**, the limit mask is displayed on the screen.
- **Burst Search Thrshld Line** - Toggles the display function of the burst search threshold line between **On** and **Off**. If set to **On**, the burst search threshold line is displayed on the screen.

The **SPAN X Scale** key accesses the menu to set the desired measurement scale and associated parameters as follows:

- **Scale/Div** - Allows you to enter a numeric value to change the

horizontal display sensitivity. The range is 1.00 ns to 1.00 s. The default setting is 100.00 μ s. However, since the **Scale Coupling** default is **On**, this value is automatically determined by the measurement result. When you set a value manually, **Scale Coupling** automatically changes to **Off**.

- **Ref Value** - Allows you to set a value for the relative time reference. The range is from -1.00 s to 10.00 s. The default setting is 0.00 s. However, since the **Scale Coupling** default is **On**, this value is automatically determined by the measurement result. When you set a value manually, **Scale Coupling** automatically changes to **Off**.
- **Ref Position** - Allows you to set the reference position to either **Top**, **Ctr** (center), or **Bot** (bottom). The default setting is **Left**.
- **Scale Coupling** - Allows you to toggle the scale coupling function between **On** and **Off**. The default setting is **On**. Upon pressing the **Restart** front-panel key or **Restart** softkey under the **Meas Control** menu, the scale coupling function automatically determines the scale per division and reference values based on the measurement results. When you set a value to either **Scale/Div** or **Ref Value** manually, **Scale Coupling** automatically changes to **Off**.

The **AMPLITUDE Y Scale** key accesses the menu to set the desired measurement scale and associated parameters as follows:

- **Scale/Div** - Allows you to enter a numeric value to change the vertical display sensitivity. The range is 0.10 to 20.00 dB with 0.01 dB resolution. The default setting is 10.00 dB. However, since the **Scale Coupling** default is **On**, this value is automatically determined by the measurement result. When you set a value manually, **Scale Coupling** automatically changes to **Off**.
- **Ref Value** - Allows you to set a value for the absolute power reference. The range is from -250.00 to 250.00 dBm with 0.01 dB resolution. The default setting is 10.00 dBm. However, since the **Scale Coupling** default is **On**, this value is automatically determined by the measurement result. When you set a value manually, **Scale Coupling** automatically changes to **Off**.
- **Ref Position** - Allows you to set the reference position to either **Top**, **Ctr** (center), or **Bot** (bottom). The default setting is **Top**.
- **Scale Coupling** - Allows you to toggle the scale coupling function between **On** and **Off**. The default setting is **On**. Upon pressing the **Restart** front-panel key or **Restart** softkey under the **Meas Control** menu, the scale coupling function automatically determines the scale per division and reference values based on the measurement results. When you set a value to either **Scale/Div** or **Ref Value** manually, **Scale Coupling** automatically changes to **Off**.

Using the Marker

The **Marker** key is not available for this measurement function.

Troubleshooting Hints

This power versus time measurement can reveal degraded or defective parts in the transmitter section of the UUT. The following examples are those areas to be checked further.

- Some faults in the DC power supply control of the transmitter power amplifier, RF power controller of the pre-power amplifier stage, or I/Q control of the baseband stage
- Some degradation in the gain and output power level of the amplifier due to the degraded gain control and/or increased distortion
- Some degradation of the amplifier linearity and other performance characteristics

Power amplifiers are one of the final stage elements of a base or mobile transmitter and are a critical part of meeting the important power and spectral efficiency specifications. Since PvT measures the time domain response of the amplifier to a complex wideband signal, it is a key measurement linking amplifier linearity and other performance characteristics to the stringent system specifications.

Making the Spurious Emissions and ACP Measurement

Purpose

Spurious Emissions Mask (SEM) & Adjacent Channel Power (ACP) measurements include the in-band and out-of-band adjacent channel power and spurious emissions. ACP, as it applies to 1xEV-DO, is the power contained in a specified frequency channel bandwidth relative to the carrier frequency. It may also be expressed as power spectral densities between the carrier and the specified offset frequency band.

As a composite measurement of out-of-channel emissions, Spurious Emissions and ACP combine both in-band and out-of-band specifications to provide useful values of figure-of-merit for spectral regrowth as well as spurious emissions produced by non-linear components and circuit blocks.

To maintain a quality data transmission and avoid adjacent channel interference, it is necessary to measure and reduce the adjacent channel power transmitted by an access network. The characteristics of adjacent channel power are mainly determined by the transmitter design, in particular the power amplifier and the low-pass filter.

Adjacent channel power is defined by the 1xEV-DO standard as the total power within the bandwidth of ± 15 kHz, with the filters edge at 750 kHz offset from the carrier frequency.

Measurement Method

This ACP measurement analyzes the total power levels within the defined carrier bandwidth and at given frequency offsets on both sides of the carrier frequency. Also, the spurious emissions measurement measures spurious signal levels in given offset/region frequencies and relates them to the carrier power. These measurements require the user to specify measurement bandwidths of the carrier channel and each of the offset frequency pairs up to 5. Each pair may be defined with unique measurement bandwidths.

A reference channel integration bandwidth method is used to measure the carrier channel power and offset/region powers. When “ACP” is selected, the adjacent channel power measurements are made with the optimized region and limits settings. When “SEM” is selected, the conducted spurious emissions measurements are made with the optimized parameter settings.

This integration bandwidth (IBW) method performs a data acquisition. In this process, the reference channel integration bandwidth (**Meas BW**) is analyzed using the automatically defined resolution bandwidth (**Res**

BW), which is much narrower than the channel bandwidth. The measurement computes an average power of the channel or offset or region over a specified number of data acquisitions, automatically compensating for resolution bandwidth and noise bandwidth.

When you set the measurement type to **Total Pwr Ref**, the results are displayed as relative power in dBc and as absolute power in dBm. When you set it to **PSD Ref** (Power Spectral Density Reference), the results are displayed as relative power in dB and as absolute power in dBm/Hz.

Making the Measurement

NOTE

The factory default settings provide a 3GPP2 compliant measurement. For special requirements, you may want to change some of the settings. Press **Meas Setup, More, Restore Meas Defaults** at any time to return all parameters for the current measurement to their default settings.

Select the desired center frequency as described in [“Changing the Frequency Channel”](#) on page 77.

Press **MEASURE, Spurious Emissions & ACP** to immediately make a spurious emissions or ACP measurement. This measurement is applicable only for BTS (Fwd) tests.

To change any of the measurement parameters from the factory default values, refer to [“Changing the Measurement Setup”](#) on page 152.

Results

The following figure shows an example result of Spectrum (Ref: Total Pwr, Seg: Offset) measurements in the graph window. The absolute peak power levels and those corresponding frequencies on both sides of the reference channel are displayed in the text window.

Figure 4-6 Spurious Emissions & ACP Measurement - SEM Mode View

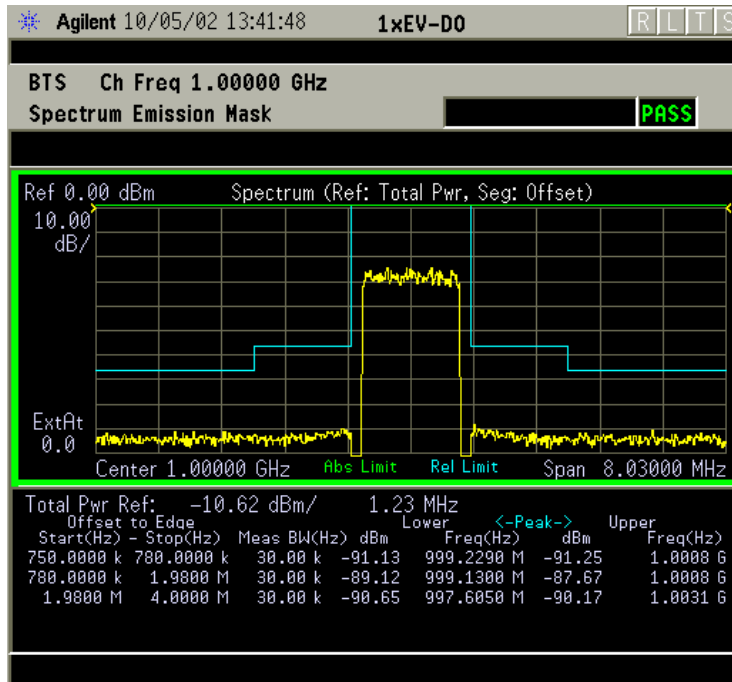

*Tester: Factory default settings
 *Input signal: -10.00 dBm, Full slot, 1xEV-DO

Changing the Measurement Setup

This table shows the factory default settings for spurious emissions and ACP measurements.

Table 4-4 Spurious Emissions and ACP Measurement Defaults

Measurement Parameter	Factory Default Condition
View/Trace	All
Display	Abs Peak Pwr & Freq
Limit Lines	On
Meas Setup:	
Avg Number	10; Off
Avg Mode	Repeat
Meas Mode	SEM
Trig Source	Free Run (Immediate)
Detector	Avg (averaged power)
Meas Type	Total Pwr Ref
Meas Offset & Interval:	
Meas Offset	325.5 μ s

Table 4-4 Spurious Emissions and ACP Measurement Defaults

Measurement Parameter	Factory Default Condition
Meas Interval	182.3 μ s
Pre-Defined Ofs/Intvl:	
Idle Slot	Idle Slot #1
Ref Channel:	
Chan Integ BW	1.23000 MHz
Chan Span	1.25000 MHz
Step Freq	12.3000 kHz; Auto
Res BW	24.6000 kHz; Auto
Spectrum Segment	Offset
Offset/Limits:	(Refer to Table 4-5 on page 158)
Offset	A
Start Freq	765.000 kHz
Stop Freq	765.000 kHz
Step Freq	1.500 kHz; Auto
Res BW	3.000 kHz; Man
Meas BW (Integ BW)	10 \times Res BW
Relative Atten	0.00 dB
Offset Side	Both
Limits:	
Abs Start	-27.00 dBm
Abs Stop	-27.00 dBm; Couple
Rel Start	-45.00 dBc
Rel Stop	-45.00 dBc; Couple
Fail Mask	Relative

Make sure the **Spurious Emissions and ACP** measurement is selected under the **MEASURE** menu. The **Meas Setup** key accesses the menus which allow you to modify the average number, average mode, and trigger source for this measurement as described in [“Measurement Setup” on page 127](#).

In addition, the following parameters can be modified according to your measurement requirements:

- **Meas Mode** - Allows you to toggle the measurement mode between **ACP** and **SEM**. If set to **ACP**, the adjacent channel power measurement is made with the optimized offset and limits defined by **Offset/Limits**. If set to **SEM**, the spurious emissions measurement is made with the optimized offset and limits defined by **Offset/Limits**.

- **Trig Source** - Allows you to select one of the trigger sources: **Free Run (Immediate)**, **Ext Front**, **Ext Rear**, **Frame**, and **Line**.
- **Detector** - Allows you to toggle the power detection type between **Avg** (average) and **Peak**. If set to **Avg**, the power in a bin is computed as RMS averaged over the entire **Meas Interval**. If set to **Peak**, the peak power in the entire **Meas Interval** is converted to the RMS value, assuming a CW signal.
- **Meas Type** - Allows you to access the menu to select one of the measurement reference types.
 - **Total Pwr Ref** - Sets the reference to the total carrier power and the measured data is shown in dBc and dBm.
 - **PSD Ref** - Sets the reference to the mean power spectral density of the carrier and the measured data is shown in dB and dBm/Hz.
- **Meas Offset & Interval** - Allows you to access the following menu to set the measurement offset and interval:
 - **Meas Offset** - Allows you to set a value of measurement offset in either μs or chips. When you enter a numeric value, the unit selection menu is shown. The range is from 0 to 1667.0 μs , or 0 to 2048 chips.
 - **Meas Interval** - Allows you to set a value of measurement interval in either μs or chips. When you enter a numeric value, the unit selection menu is shown. The range is from 0 μs to 10.000 ms, or 13 to 224 chips.
 - **Pre-Defined Ofs/Intvl** - Allows you to access the menu to select one of the predefined measurement offsets and intervals depending on the slots. The slot definitions are summarized in the illustration and table below.
 - Idle Slot** - Allows you to access the menu to select either idle slot #1 or #2 for the preset measurement offset and interval.
 - Idle Slot #1** - Refer to the illustration and table below for details.
 - Idle Slot #2** - Refer to the illustration and table below for details.
 - Half Slot** - Allows you to access the menu to select either half slot #1 or #2 for the preset measurement offset and interval.
 - Half Slot #1** - Refer to the illustration and table below for details.
 - Half Slot #2** - Refer to the illustration and table below for details.

- ❑ **Full Slot** - Allows you to set the full slot with 2048 chips for the preset measurement offset and interval.

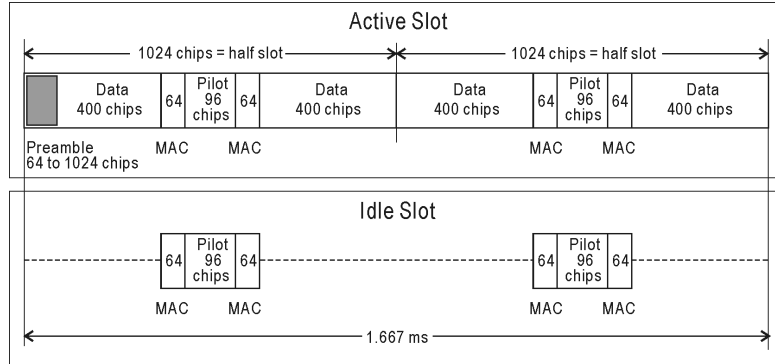

Selection	Meas Offset		Meas Interval	
	Time (μs)	Chips	Time (μs)	Chips
Idle Slot #1	325.5	400	182.3	224
Idle Slot #2	1158.9	1424	182.3	224
Half Slot #1	0.0	0	833.3	1024
Half Slot #2	833.3	1024	833.3	1024
Full Slot	0.0	0	1666.7	2048

- **Ref Channel** - Allows you to define the reference channel in the following terms:
 - **Chan Integ BW** - Allows you to specify a value for the channel integration bandwidth. The range is from 30.0 kHz to 20.00 MHz.
 - **Chan Span** - Allows you to specify a value for the channel span to be measured. The range is from 100.000 kHz to 10.0000 MHz.
 - **Step Freq** - Allows you to specify the step frequency to make measurements ranging from 100.0 Hz to 7.50000 MHz, and to toggle this function between **Auto** and **Man**. If set to **Auto**, this is automatically set to half the **Res BW** setting. If set to **Man**, the step frequency is manually set independently from **Res BW**.
 - **Res BW** - Allows you to specify the resolution bandwidth ranging from 1.000 kHz to 1.000 MHz, and to toggle this function between **Auto** and **Man**. If set to **Auto**, **Res BW** is automatically set to one 50th of **Chan Integ BW**. The Gaussian shaped filter is used.
- **Spectrum Segment** - Allows you to toggle the frequency spectrum segment between **Offset** and **Region**. According to this selection, either the **Offset/Limits** menu or the **Region & Limits** menu is available. When you select **Offset**, ACP or spurious emissions measurements are made depending on the **Meas Type** selection.

When you select **Region**, spurious emissions measurements are made.

- **Offset/Limits** - Allows you to access the menus to change the following parameters for offset frequency settings and pass/fail test conditions, when you set **Spectrum Segment** to **Offset**. For both the **SEM** and **ACP** measurement modes the individual offsets and limits are configurable. [Table 4-5](#) and [Table 4-6](#) show the default settings for SEM and ACP mode measurements, respectively.

When **Spectrum Segment** is set to **Offset**, the frequency values at Start (Hz) and Stop (Hz) are shown as Offset to Edge in the measurement result window considering the measurement bandwidth, as it is different from the offset frequency center as shown in the following illustration. In addition, if **Meas Mode** is set to **ACP**, each frequency pair in Start (Hz) and Stop (Hz) becomes the same frequency values for adjacent channel power measurements. For example, if the measurement bandwidth is set to 30 kHz, the first offset center frequency can be 765 kHz and the offset to edge frequency can be 750 kHz.

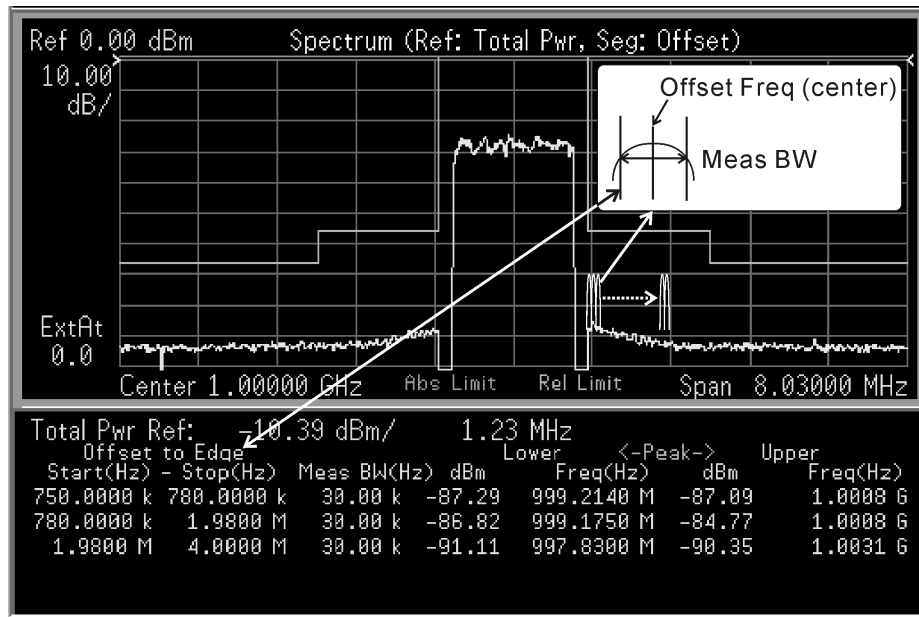

- **Offset** - Allows you to access the memory selection menu from **A** through **E** to store up to 5 sets of values for **Start Freq**, **Stop Freq**, **Step Freq**, **Res BW**, and **Limits**. Only one memory selection at a time (A, B, C, D, or E) is shown on this key label.
- **Start Freq** - Allows you to specify a value for the start center frequency, and to toggle this function between **On** and **Off**, for each offset. The frequency range is 10.0000 kHz to 100.000 MHz with 100 Hz resolution. However, the high end is limited to the setting of **Stop Freq**. When **Spectrum Segment** is set to **Offset**, the frequency values at Start (Hz) are shown as Offset to Edge in

the measurement result window considering the measurement bandwidth.

- **Stop Freq** - Allows you to specify a value for the stop center frequency. The frequency range is from 10.0000 kHz to 100.000 MHz with 100 Hz resolution, for each offset. The low end is limited to the setting of **Start Freq**. When **Spectrum Segment** is set to **Offset**, the frequency values at **Stop** (Hz) are shown as **Offset to Edge** in the measurement result window considering the measurement bandwidth.
- **Step Freq** - Allows you to specify a value for the step frequency. The frequency range is from $(\text{Stop Freq} - \text{Start Freq})/10000$ to $(\text{Stop Freq} - \text{Start Freq})$, and to toggle this function between **Auto** and **Man**, for each offset. If set to **Auto**, the step frequency is automatically set to half the **Res BW** setting. When you set **Meas BW** to other than 1 of **Res BW**, **Step Freq** is disabled because **Res BW** is automatically set to the step frequency.
- **Res BW** - Allows you to specify a value for the resolution bandwidth. The range is from 300.0 Hz to 7.50000 MHz with 100 Hz resolution, and to toggle this function between **Auto** and **Man**, for each offset. If set to **Auto**, **Res BW** is automatically set to one 50th of $(\text{Stop Freq} - \text{Start Freq})$. The Gaussian shaped filter is used. The next figure illustrates the relationships between **Meas BW**, **Start Freq**, and **Stop Freq**.

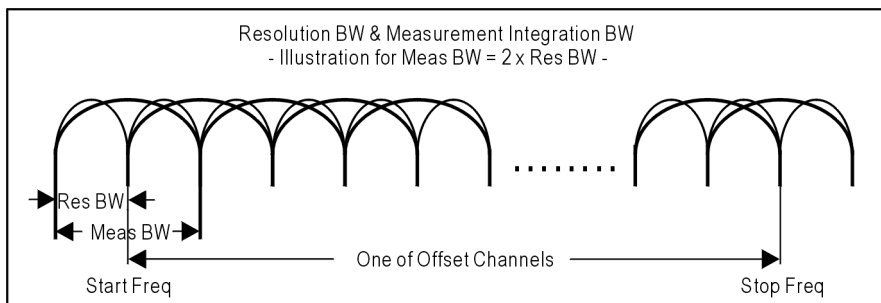

- **Meas BW (Integ BW)** - Allows you to specify a multiplier of **Res BW** for the measurement integration bandwidth. The range is from 1 to an integer derived from $(\text{Stop Freq} - \text{Start Freq})/\text{Res BW}$. Refer to the illustration under **Res BW** above.
- **Relative Atten** - Allows you to enter an attenuation value to adjust the relative level limits ranging from -40.00 to 40.00 dB with 0.01 dB resolution. The default attenuation is the same as the one used by **Ref Channel**.
- **Offset Side** - Allows you to specify which offset side is to be measured. Selections are **Neg** (negative offset), **Both**, and **Pos** (positive offset).
- **Limits** - Allows you to access the following menu to set up an absolute and relative limit level and fail condition for each offset:

- ❑ **Abs Start** - Allows you to enter an absolute level limit at **Start Freq.** The range is from -200.00 to +50.00 dBm with 0.01 dB resolution.
- ❑ **Abs Stop** - Allows you to enter an absolute level limit at **Stop Freq.** The range is from -200.00 to +50.00 dBm with 0.01 dB resolution, and to toggle this function between **Couple** and **Man.** If set to **Couple**, **Abs Stop** is coupled to **Abs Start** to make a flat limit line. If set to **Man**, **Abs Start** and **Abs Stop** can take different values to make a sloped limit line.
- ❑ **Rel Start** - Allows you to enter a relative level limit at **Start Freq.** The range is from -150.00 to +50.00 dBc with 0.01 dB resolution.
- ❑ **Rel Stop** - Allows you to enter a relative level limit at **Stop Freq.** The range is from -150.00 to +50.00 dBc with 0.01 dB resolution, and to toggle this function between **Couple** and **Man.** If set to **Couple**, **Rel Stop** is coupled to **Rel Start** to make a flat limit line. If set to **Man**, **Rel Start** and **Rel Stop** can take different values to make a sloped limit line.
- ❑ **Fail Mask** - Allows you to access the following menu to select one of the logic keys for fail conditions between the measurement results and the test limits:

Absolute - Fail is shown if one of the absolute measurement results is larger than the limit for **Abs Start** and/or **Abs Stop**.

Relative - Fail is shown if one of the relative measurement results is larger than the limit for **Rel Start** and/or **Rel Stop**. This is the default selection for the offset **A** and **B**.

Abs AND Rel - Fail is shown if one of the absolute measurement results is larger than the limit for **Abs Start** and **Abs Stop** AND one of the relative measurement results is larger than the limit for **Rel Start** and **Rel Stop**.

Abs OR Rel - Fail is shown if one of the absolute measurement results is larger than the limit for **Abs Start** and **Abs Stop** OR one of the relative measurement results is larger than the limit for **Rel Start** and **Rel Stop**.

Table 4-5 SEM Mode Offset & Limit Defaults

Offset	Start Freq (MHz)	Stop Freq (MHz)	Res BW (kHz)	Meas BW (kHz)	Abs Start (dBm)	Abs Stop (dBm)	Rel Start (dBc)	Rel Stop (dBc)	Fail Mask
A, On	0.7650	0.7950	3.000	30.00	-27.00	-27.00	-45.00	-45.00	Rel
B, On	0.7950	1.9950	30.00	30.00	-27.00	-27.00	-45.00	-45.00	Rel
C, Off	1.9950	4.0150	30.00	30.00	-27.00	-27.00	-55.00	-55.00	Rel

Table 4-5 SEM Mode Offset & Limit Defaults

Offset	Start Freq (MHz)	Stop Freq (MHz)	Res BW (kHz)	Meas BW (kHz)	Abs Start (dBm)	Abs Stop (dBm)	Rel Start (dBc)	Rel Stop (dBc)	Fail Mask
D, Off	3.2531	4.0031	6.25	6.25	-46.00	-46.00	-55.00	-55.00	Abs
E, Off	7.5000	12.500	1000.0	1000.0	-13.00	-13.00	-55.00	-55.00	Rel

Table 4-6 ACP Mode Offset & Limit Defaults

Offset	Start Freq (MHz)	Stop Freq (MHz)	Res BW (kHz)	Meas BW (kHz)	Abs Start (dBm)	Abs Stop (dBm)	Rel Start (dBc)	Rel Stop (dBc)	Fail Mask
A, On	0.7650	0.7650	3.000	30.00	-27.00	-27.00	-45.00	-45.00	Rel
B, On	1.9950	1.9950	30.00	30.00	-27.00	-27.00	-55.00	-55.00	Rel
C, Off	3.1250	3.1250	30.00	30.00	-13.00	-13.00	-55.00	-55.00	Abs
D, Off	4.0000	4.0000	30.00	30.00	-13.00	-13.00	-55.00	-55.00	Rel
E, Off	7.5000	7.5000	30.00	30.00	-13.00	-13.00	-55.00	-55.00	Rel

- **Region & Limits** - Allows you to access the menus to change the following parameters for region frequency settings and pass/fail test conditions, if **Spectrum Segment** is set to **Region**. Table 4-7 shows the default settings for SEM mode measurements.
 - **Region** - Allows you to access the memory selection menu from **A** through **E** to store up to 5 sets of values for **Start Freq**, **Stop Freq**, **Step Freq**, **Res BW**, and **Limits**. Only one memory selection at a time (A, B, C, D, or E) is shown on this key label. The default setting is **A**.
 - **Start Freq** - Allows you to specify a value for the start frequency, and to toggle this function between **On** and **Off**, for each region. The frequency range is 329.000 MHz to 3.67800 GHz with 1 kHz resolution. However, the high end is limited to the setting of **Stop Freq**. The default settings are 1.92000 GHz and **On**.
 - **Stop Freq** - Allows you to specify a value for the stop frequency. The frequency range is from 329.000 MHz to 3.67800 GHz with 1 kHz resolution, for each region. The low end is limited to the setting of **Start Freq**. The default setting is 1.98000 GHz.
 - **Step Freq** - Allows you to specify a value for the step frequency. The range is from $(\text{Stop Freq} - \text{Start Freq})/10000$ to $(\text{Stop Freq} - \text{Start Freq})$, and to toggle this function between **Auto** and **Man**, for each region. If set to **Auto**, the step frequency is automatically set to half the **Res BW** setting. The default settings are 600.000 kHz and **Auto**.

- **Res BW** - Allows you to specify a value for the resolution bandwidth. The frequency range is from 1.000 kHz to 7.5000 MHz with 100 Hz resolution, and to toggle this function between **Auto** and **Man**, for each region. If set to **Auto**, the resolution bandwidth is automatically set to one 50th of (**Stop Freq** – **Start Freq**). The Gaussian shaped filter is used. The default settings are 1.20000 MHz and **Auto**.
- **Relative Atten** - Allows you to enter an attenuation value to adjust the relative level limits. The range is from –40.00 to 40.00 dB with 0.01 dB resolution. The default attenuation is the same as the one used for **Ref Channel**.
- **Limits** - Allows you to access the following menu to set up an absolute and relative limit level and fail condition for each region:
 - Abs Start** - Allows you to enter an absolute level limit at **Start Freq**. The range is from –200.00 to +50.00 dBm with 0.01 dB resolution. The default setting is –50.00 dBm.
 - Abs Stop** - Allows you to enter an absolute level limit at **Stop Freq**. The range is from –200.00 to +50.00 dBm with 0.01 dB resolution, and to toggle this function between **Couple** and **Man**. If set to **Couple**, **Abs Stop** is coupled to **Abs Start** to make a flat limit line. If set to **Man**, **Abs Start** and **Abs Stop** can take different values to make a sloped limit line. The default settings are –50.00 dBm and **Couple**.
 - Rel Start** - Allows you to enter a relative level limit. The range is from –150.00 to +50.00 dBc with 0.01 dB resolution. The default settings are –30.00 dBm.
 - Rel Stop** - Allows you to enter a relative level limit at **Stop Freq**. The range is from –150.00 to +50.00 dBc with 0.01 dB resolution, and to toggle this function between **Couple** and **Man**. If set to **Couple**, **Rel Stop** is coupled to **Rel Start** to make a flat limit line. If set to **Man**, **Rel Start** and **Rel Stop** can take different values to make a sloped limit line. The default settings are –30.00 dBm and **Couple**.
 - Fail Mask** - Allows you to access the following menu to select one of the logic keys for fail conditions between the measurement results and the test limits. The default selection is **Absolute**.
 - Absolute** - Fail is shown if one of the absolute spurious emissions measurement results is larger than the limit for **Abs Start** and/or **Abs Stop**. This is the default selection for each region.
 - Relative** - Fail is shown if one of the relative spurious emissions measurement results is larger than the limit for **Rel Start** and/or **Rel Stop**.

Abs AND Rel - Fail is shown if one of the absolute spurious emissions measurement results is larger than the limit for **Abs Start** and **Abs Stop** AND one of the relative spurious emissions measurement results is larger than the limit for **Rel Start** and **Rel Stop**.

Abs OR Rel - Fail is shown if one of the absolute spurious emissions measurement results is larger than the limit for **Abs Start** and **Abs Stop** OR one of the relative spurious emissions measurement results is larger than the limit for **Rel Start** and **Rel Stop**.

Table 4-7 SEM Mode Region & Limit Defaults

Region	Start Freq (GHz)	Stop Freq (GHz)	Step Freq (kHz)	Res BW (kHz)	Abs Start (dBm)	Abs Stop (dBm)	Rel Start (dBc)	Rel Stop (dBc)	Fail Mask
A, On	1.9200	1.9800	600.0	1200.0	-50.00	-50.00	-30.00	-30.00	Abs
B, On	1.8935	1.9196	261.0	522.0	-50.00	-50.00	-30.00	-30.00	Abs
C, On	2.1000	2.1050	50.0	100.0	-50.00	-50.00	-30.00	-30.00	Abs
D, Off	2.1750	2.1800			-50.00	-50.00	-30.00	-30.00	Abs
E, Off	0.8000	1.0000			-50.00	-50.00	-30.00	-30.00	Abs

Changing the View

The **View/Trace** key accesses the menu to select the desired view of the measurement result depending on the selection of **Spectrum Segment**.

If **Spectrum Segment** is set to **Offset**, the following menu is shown:

- **All** - In the factory default condition, the ACP or spurious emissions measurement graph is displayed with all of the active offsets in the graph window as shown in [Figure 4-6 on page 152](#).
- **Offset A** through **Offset E** - Each of ACP or spurious emissions measurement results, up to 5 sets of offsets, is shown in the graph window. Each offset label set to **Off** is grayed out.
- **Offset Side** - Allows you to toggle the display function of the offset sides between **Pos** (positive) and **Neg** (negative).

If **Meas Mode** is set to **ACP**, the following screen is displayed:

Figure 4-7 Spurious Emissions and ACP Measurement - ACP Mode View

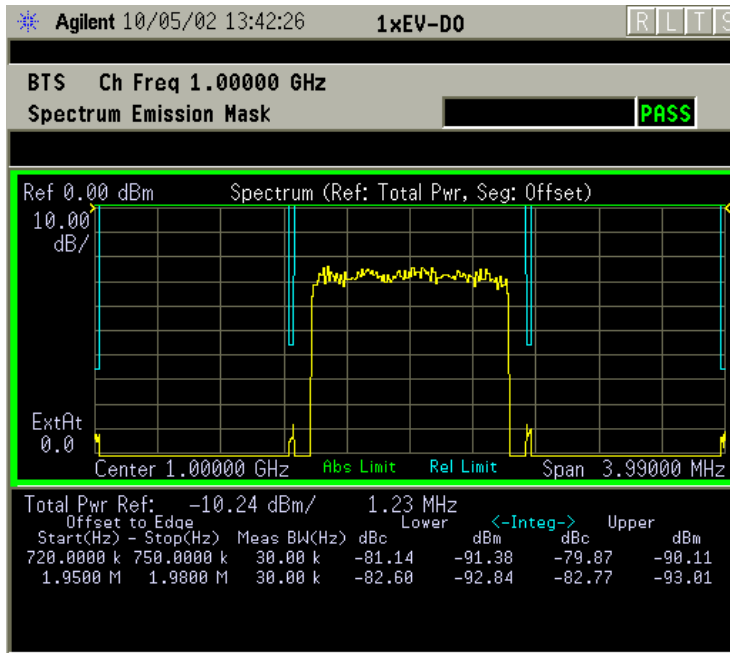

*Tester: Meas Mode = ACP,
 Others = Factory default settings

*Input signal: -10.00 dBm, Full slot, 1xEV-DO

If **Spectrum Segment** is set to **Region**, the following menu is shown:

- **All** - The spurious emissions measurement graph is displayed with all of the active regions in the graph window as shown below:

Figure 4-8 Spurious Emissions Measurement - All Regions View

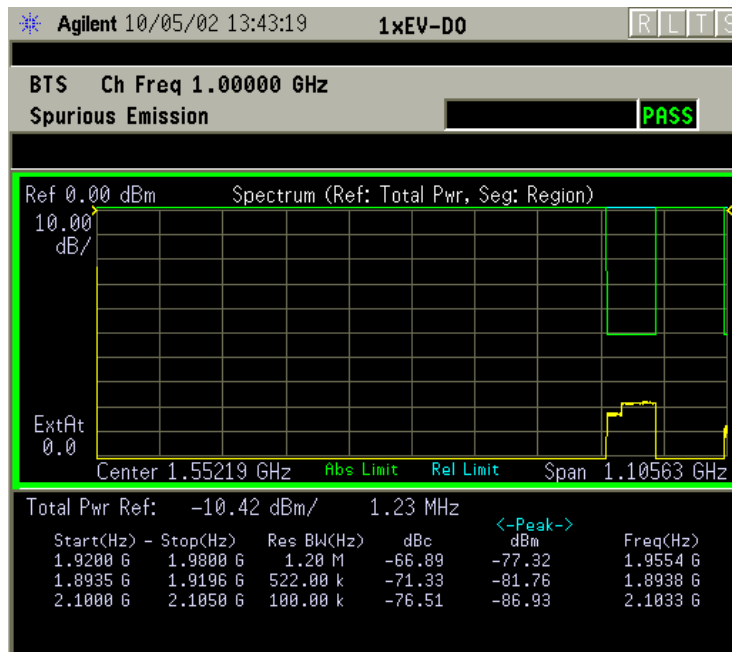

*Tester: Spectrum Segment = Region,
 Others = Factory default settings

*Input signal: -10.00 dBm, Full slot, 1xEV-DO

- **Region A** through **Region E** - Each of spurious emissions measurement results, up to 5 sets of regions, is shown in the graph window. Each region label set to **Off** is grayed out.

Changing the Display

The **AMPLITUDE Y Scale** key accesses the menu to allow the following settings for desired graph displays:

- **Scale/Div** - Allows you to enter a value to change the vertical display sensitivity. The range is 0.10 to 20.00 dB with 0.01 dB resolution. The default setting is 10.00 dB. However, since the **Scale Coupling** default is **On**, this value is automatically determined by the measurement result. When you set a value manually, **Scale Coupling** automatically changes to **Off**.
- **Ref Value** - Allows you to set a value for the absolute power reference. The range is from -250.00 to 250.00 dBm with 0.01 dB resolution. The default setting is 10.00 dBm. However, since the **Scale Coupling** default is **On**, this value is automatically determined by the measurement result. When you set a value manually, **Scale Coupling** automatically changes to **Off**.
- **Ref Position** - Allows you to set the reference position to either **Top**, **Ctr** (center), or **Bot** (bottom). The default setting is **Top**.
- **Scale Coupling** - Allows you to toggle the scale coupling function between **On** and **Off**. The default setting is **On**. Upon pressing the **Restart** front-panel key or the **Restart** softkey under the **Meas Control** menu, the scale coupling function automatically determines the scale per division and reference values based on the measurement results. When you set a value to either **Scale/Div** or **Ref Value** manually, **Scale Coupling** automatically changes to **Off**.

The **Display** key also accesses the menu to allow the following selections to control the screen display:

- **Limit Lines** - Allows you to toggle the limit lines display function for spurious emissions or ACP measurements between **On** and **Off**. If set to **On**, the absolute limit lines or the relative limit lines are shown on the measurement display.
- **Abs Peak Pwr & Freq** - Allows you to read the absolute peak power levels in dBm and corresponding frequencies in the text window. This key is disabled if **Spectrum Segment** is set to **Region**.
- **Rel Peak Pwr & Freq** - Allows you to read the relative peak power levels in dBc and corresponding frequencies in the text window. This

key is disabled if **Spectrum Segment** is set to **Region**.

- **Integrated Power** - Allows you to read the absolute and relative power levels, integrated throughout the bandwidths between the start and stop frequencies, in the text window. This key is disabled if **Spectrum Segment** is set to **Region**.

Using the Markers

The **Marker** front-panel key accesses the menu to configure the markers.

- **Select 1 2 3 4** - Allows you to activate up to four markers with the corresponding numbers, respectively. The selected number is underlined and its function is defined by pressing the **Function** key. The default is 1.
- **Normal** - Allows you to activate the selected marker to read the time position and amplitude of the marker on the measurement trace, for example. The marker position is controlled by the **RPG** knob.
- **Delta** - Allows you to read the differences in time positions and amplitudes between the selected marker and the next.
- **Function** - Allows you to define the selected marker function to be **Band Power**, **Noise**, or **Off**. The default is **Off**. For measuring **Band Power**, you need to place the **Normal** marker and then place the **Delta** marker.
- **Trace** - Allows you to place the selected marker on the **Spectrum** trace.
- **Off** - Allows you to turn off the selected marker.
- **Shape Diamond** - Allows you to access the menu to define the selected marker shape to be **Diamond**, **Line**, **Square**, or **Cross**. The default is **Diamond**.
- **Marker All Off** - Allows you to turn off all of the markers.

The front-panel **Search** key performs a peak search when pressed. A marker will automatically be activated at the highest peak.

Troubleshooting Hints

ACP and spurious emissions measurements can reveal the presence of degraded or defective parts in the transmitter section of the UUT. The following are examples of problems which, once indicated by testing, may require further attention:

- Faulty DC power supply control of the transmitter power amplifier
- RF power controller of the pre-power amplifier stage
- I/Q control of the baseband stage

- Reduction in the gain and output power level of the amplifier due to a degraded gain control and/or increased distortion
- Degradation of amplifier linearity and other performance characteristics

Power amplifiers are one of the final stage elements of a base transmitter and play a critical part in meeting the important power and spectral efficiency specifications. Measuring the spectral response of these amplifiers to complex wideband signals is crucial to linking amplifier linearity and other performance characteristics to the stringent system specifications.

Making the Occupied Bandwidth Measurement

Purpose

Occupied bandwidth measurements express the percentage of the transmitted power within a specified bandwidth. This percentage is typically 99%.

The spectrum shape of a 1xEV-DO signal can give useful qualitative insight into transmitter operation. Any distortion to the spectrum shape can indicate problems in transmitter performance.

Measurement Method

The instrument uses digital signal processing (DSP) to sample the input signal and convert it to the frequency domain. With the instrument tuned to a fixed center frequency, samples are digitized at a high rate with DSP hardware, and then converted to the frequency domain with FFT software.

The total power within the measurement frequency span is integrated for its 100% of power. The frequencies of 0.5% of the total power are then calculated to get 99.0% bandwidth.

Making the Measurement

NOTE

The factory default settings provide a 3GPP2 compliant measurement. For special requirements, you may need to change some of the settings. Press **Meas Setup, More, Restore Meas Defaults** at any time to return all parameters for the current measurement to their default settings.

Select the desired center frequency as described in [“Changing the Frequency Channel” on page 77](#).

Press **MEASURE, Occupied BW** to immediately make an occupied bandwidth measurement. This measurement is applicable for BTS (Fwd) and MS (Rev) tests.

To change any of the measurement parameters from the factory default values, refer to [“Changing the Measurement Setup” on page 167](#).

Results

The following figure shows an example result of Occupied BW measurements. The occupied bandwidth graph is shown in the graph window. The occupied bandwidth for 99.00% of the total power and the total power level are shown in the text window.

Figure 4-9 Occupied Bandwidth Measurement

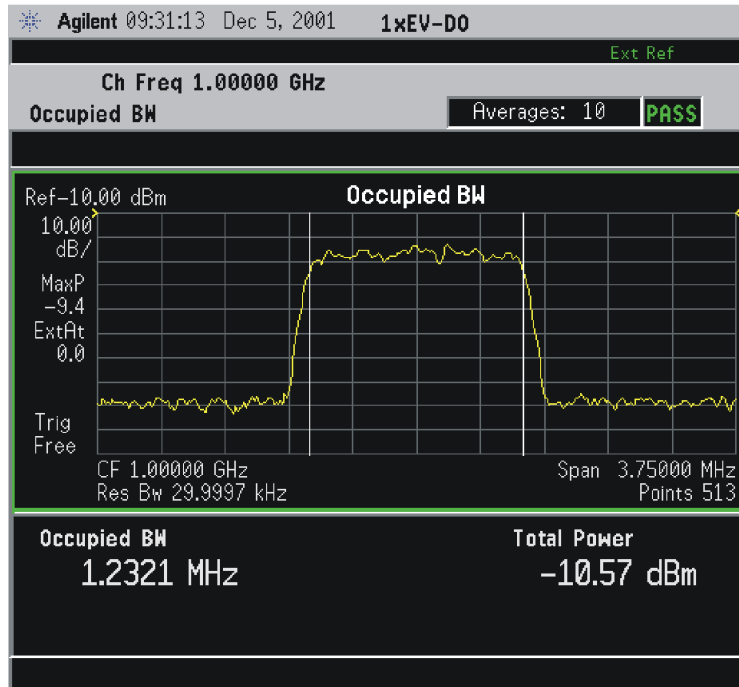

- *Meas Setup: Factory default settings
- *Input signal: -10.00 dBm, Full slot, 1xEV-DO

Changing the Measurement Setup

This table shows the factory default settings for occupied bandwidth measurements.

Table 4-8 Occupied Bandwidth Measurement Defaults

Measurement Parameter	Factory Default Condition
Meas Setup:	
Avg Number	10; On
Avg Mode	Repeat
Span	3.75000 MHz
Res BW	30.000 kHz
Trig Source	Free Run (Immediate)
Limit Test	On
Limit	1.48000 MHz
Advanced	
FFT Window	Gaussian (Alpha 3.5)

Making Measurements

Make sure the **Occupied BW** measurement is selected under the **MEASURE** menu. The **Meas Setup** key accesses the menu which allows you to modify the average number, average mode, and trigger source for this measurement as described in “[Measurement Setup](#)” on page 127.

In addition, the following parameters can be modified according to your measurement requirements:

- **Span** - Allows you to specify a value for the frequency span in which the total power is measured. The range is 10.000 kHz to 10.000 MHz with 1 Hz resolution.
- **Res BW** - Allows you to specify a value for the resolution bandwidth. The frequency range is 1.000 kHz to 1.00000 MHz. A narrower bandwidth will result in a longer data acquisition time but you will be able to examine the signal more closely.
- **Limit Test** - Allows you to toggle the limit test function between **On** and **Off**, for occupied bandwidth measurements.
- **Limit** - Allows you to specify a value for the limit frequency with which the limit test is made. The range is 10.000 kHz to 10.000 MHz with 1 Hz resolution.
- **Advanced** - Allows you to access the selection menu of FFT windows.
 - **FFT Window** - Allows you to access the following selection menu for FFT windows. If you are familiar with FFT windows, you can use other digital filters but the use of the flat top filter is recommended. Changes from the default setting may result in invalid data.
 - Flat Top** - Select this filter for best amplitude accuracy by reducing scalloping error.
 - Uniform** - Select this filter to have no active window.
 - Hanning** - Press this key to activate the Hanning filter.
 - Hamming** - Press this key to activate the Hamming filter.
 - Gaussian (Alpha 3.5)** - Press this key to activate the Gaussian filter with an alpha of 3.5.
 - Blackman** - Press this key to activate the Blackman filter.
 - Blackman-Harris** - Press this key to activate the Blackman-Harris filter.
 - K-B 70dB, 90dB, 110dB (Kaiser-Bessel)** - Allows you to select one of the Kaiser-Bessel filters with sidelobes at -70, -90, or -110 dB.

Changing the View

The **View/Trace** menu is not available for this measurement.

Changing the Display

The **AMPLITUDE Y Scale** key accesses the menu to set the desired measurement scale and associated parameters:

- **Scale/Div** - Allows you to enter a value to change the vertical display sensitivity. The range is 0.10 to 20.00 dB with 0.01 dB resolution. The default setting is 10.00 dB. However, since the **Scale Coupling** default is **On**, this value is automatically determined by the measurement result. When you set a value manually, **Scale Coupling** automatically changes to **Off**.
- **Ref Value** - Allows you to set a value for the absolute power reference. The range is from -250.00 to 250.00 dBm with 0.01 dB resolution. The default setting is 10.00 dBm. However, since the **Scale Coupling** default is **On**, this value is automatically determined by the measurement result. When you set a value manually, **Scale Coupling** automatically changes to **Off**.
- **Ref Position** - Allows you to set the reference position to either **Top**, **Ctr** (center), or **Bot** (bottom). The default setting is **Top**.
- **Scale Coupling** - Allows you to toggle the scale coupling function between **On** and **Off**. The default setting is **On**. Upon pressing the **Restart** front-panel key or the **Restart** softkey under the **Meas Control** menu, the scale coupling function automatically determines the scale per division and reference values based on the measurement results. When you set a value to either **Scale/Div** or **Ref Value** manually, **Scale Coupling** automatically changes to **Off**.

Using the Marker

The **Marker** menu is not available for this measurement function.

Troubleshooting Hints

Any distortion such as harmonics or intermodulation, for example, produces undesirable power outside the specified bandwidth.

Shoulders on either side of the spectrum shape indicate spectral regrowth and intermodulation. Rounding or sloping of the top shape can indicate filter shape problems.

Making the Forward Link Code Domain Measurement

This section describes making BTS tests, also known as forward link tests. If you are going to make MS tests or reverse link tests, see [“Making the Reverse Link Code Domain Measurement” on page 181](#).

Purpose

Since the code domain measurements despread and descramble the 1xEV-DO signal into its physical channels, the number of active channels of various symbol rates (which are denoted by widths) can be observed. The width of the channel is inversely proportional to the Walsh code length in number of bits. In the code domain, there is a fixed amount of code space for a given chip rate. Therefore, by using the different Walsh codes, the system can dynamically allocate the code spaces for high speed data users.

This code domain power composite view provides information about the in-channel characteristics of the 1xEV-DO signal. It directly informs the user of the active channels with their individual channel powers. The composite view also shows which data rates are active and the corresponding amount of code space used. The following are conditions under which a general unlock can occur: the Pilot signal is too low in power or no Pilot signal available, the frequency error is too large, or a frequency inversion is present.

When the level of the code domain noise floor is too high, relative to a reference or an expected level, one of the possible causes might be due to CW interference, like local oscillator feedthrough or spurs. I/Q modulation impairments can be another source of this uncorrelated noise. The I/Q demodulation measurements can reveal errors such as I/Q gain imbalance or I/Q quadrature error

Measurement Method

This procedure measures the power levels of the spread channels in composite RF channels. The **Measure** default in the **Meas Control** menu is **Single** for this measurement.

The code domain measurement displays the power for each of the spread channels, relative to the total power within the 1.230 MHz channel bandwidth centered at the center frequency. Each spread channel level is displayed as an individual vertical bar with a different width determined by a spread rate. Because this is a relative measurement, the unit of measure is dB (not dBm or watts). This allows a comparison of signal levels between the Pilot, MAC, and Traffic channels.

The following displays are available for this measurement:

- Power Graph & Metrics - The transmitted energy associated with each of the symbol rates and Walsh codes is shown in the graph window. The following channel powers along with the total absolute power and the total active channel power are shown in the text window for BTS tests:

I/Q Combined Power Bar		
Chan Type	Off	On
Pilot or MAC	I Avg Active Ch: I Max Inactive Ch: Q Avg Active Ch: Q Max Inactive Ch: Active Channels:	Max Active Ch: Avg Active Ch: Max Inactive Ch: Avg Inactive Ch: Active Channels:
Data	I Max Active Ch: I Min Active Ch: Q Max Active Ch: Q Min Active Ch: Active Channels: Preamble Length: Preamble MAC Index:	Max Active Ch: Min Active Ch: Active Channels: Preamble Length: Preamble MAC Index:

- I/Q Polar & Power Graph - The graphs of the code domain power, the symbol I/Q polar, and the chip power versus time are shown in the graph windows.

Making the Measurement

NOTE

The factory default settings provide a 3GPP2 compliant measurement. For special requirements, you may need to change some of the settings. Press **Meas Setup**, **More**, **Restore Meas Defaults** at any time to return all parameters for the current measurement to their default settings.

Select the desired center frequency as described in [“Changing the Frequency Channel”](#) on page 77.

For PSA with Option 1DS Internal Preamplifier, see [“Configuring the Input Condition”](#) on page 72 for details of **Int Preamp** and **Attenuator** operation.

Press **MEASURE**, **Code Domain** to immediately make a code domain power measurement. This section describes making BTS tests, also known as forward link tests. If you are going to make MS tests or reverse link tests, see [“Making the Reverse Link Code Domain Measurement”](#) on page 181.

To change any of the measurement parameters from the factory default values, refer to [“Changing the Measurement Setup”](#) on page 172.

Results

The following figure shows an example result of Code Domain Power measurement. In the graph window, the active channels are highlighted and the Walsh code numbers are shown with the horizontal position with those heights for the measured power levels. In addition to the total power, powers for total active channels, pilot channel, synchronizing channel, and the number of active channels and time offset, are shown in the text window.

Figure 4-10 Code Domain Measurement - Power Graph & Metrics View

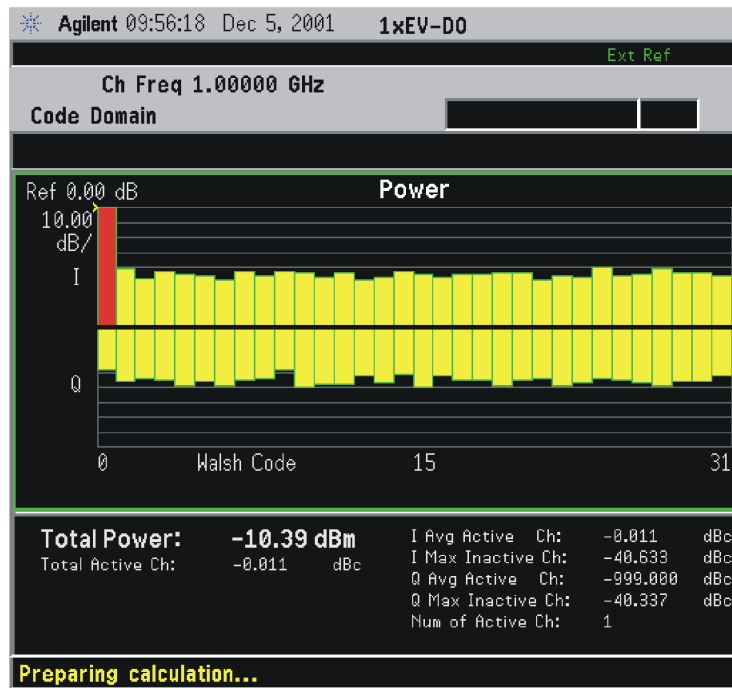

*Meas Setup: Factory default settings

*Input signal: -10.00 dBm, Full slot, 1xEV-DO

Changing the Measurement Setup

This table shows the factory default settings for code domain power measurements.

Table 4-9 Code Domain Power Measurement Defaults

Measurement Parameter	Factory Default Condition
View/Trace	Power Graph & Metrics
Display:	
Code Order	Hadamard
I/Q Combined Power Bar	Off

Table 4-9 Code Domain Power Measurement Defaults

Measurement Parameter	Factory Default Condition
Meas Setup:	
Meas Type	Rel (relative)
Walsh Code Number	0
Meas Interval	1.0 slots
Meas Offset	0.0 slots
PN Offset	0 × 64 [chips]
Channel Type	Pilot
Data Ch Type	QPSK (if Channel Type is Data)
Preamble Len	---- chips; Auto
Active Data Chan	Auto
Capture Intvl	5 slots
Trig Source	Free Run (Immediate)
Spectrum	Normal
Meas Control: Measure	Single
Advanced	
Active Set Th	---- dB; Auto
Chip Rate	1.228800 MHz
Phase Compensation	Off
ADC Range: Manual	-6 dB (for E4406A), None (for PSA)

Make sure the **Code Domain** measurement is selected under the **MEASURE** menu. Press the **Meas Setup** key to access the menu which allows you to modify the trigger source for this measurement as described in [“Measurement Setup” on page 127](#). Also, press the **Meas Control** key to access the menu which allows you to change **Measure** from **Single** to **Cont** (continuous) as described in [“Measurement Control” on page 126](#).

In addition, the following parameters can be modified according to your measurement requirement:

- **Meas Type** - Allows you to toggle the code domain power measurement type between **Rel** (relative) and **Abs** (absolute). If set to **Rel**, the measurement is made in the relative power in dBc. If set to **Abs**, the measurement is made in the absolute power in dBm.

- **Walsh Code Number** - Allows you to set the Walsh code number. The range is 0 to 31 for Pilot channel, 0 to 63 for MAC channel, or 0 to 15 for Data channel.
- **Meas Interval** - Allows you to set the time interval in slots over which the chip power measurement is made. The range is 0.0 to **Capture Intvl** slots. The marker lines reflecting this value are displayed in the chip power graph of the **I/Q Polar & Power Graph** displays.
- **Meas Offset** - Allows you to set the number of offsets in slots to make a chip power measurement. The range is 0.0 to (**Capture Intvl** – 1) slots. The marker lines shift left or right by this value in the chip power graph of the **I/Q Polar & Power Graph** display.
- **PN Offset** - Allows you to set the number of PN offsets in the unit of 64 chips to make a symbol power measurement. The range is 0 to 511. This value corresponds to the time offset between the trigger signal and the external frame signal.
- **Channel Type** - Allows you to access the menus to specify one of the channel types:
 - **Pilot** - The channel type is set to the pilot channel.
 - **MAC** - The channel type is set to the medium access control (MAC) channel.
 - **Data** - The channel type is set to the data channel.
- **Data Ch Type** - Allows you to select one of the following data channel types if **Channel Type** is set to **Data**, otherwise this key is disabled:
 - **QPSK** - The data channel type is set to the quadrature phase shift keying.
 - **8PSK** - The data channel type is set to the eight phase shift keying.
 - **16QAM** - The data channel type is set to the sixteen quadrature amplitude modulation.
- **Preamble Len** - Allows you to specify the preamble length in number of chips from the first chip in the data channel, and to toggle the length detection mode between **Auto** and **Man** (manual). If set to **Auto**, the preamble length is automatically detected showing “---- chips” on this key. If set to **Man**, you can enter a value in number of chips to specify the preamble length that is excluded from the data calculation. The selections are 0, 64, 128, 256, 512, and 1024.
- **Active Data Chan** - Allows you to toggle the active channel ID detection between **Auto** and **Predef** (predefined). If set to **Auto**, the active channel ID detection is automatically made for the data channel measurement. If set to **Predef**, the predefined active channel detection is used for the data channel measurement.

- **Capture Intvl** - Allows you to set a value in number of slots for the measurement interval to make a chip power measurement. The range is 0.5 to 32.0 slots with 0.5 slot resolution, in conjunction with the **Meas Interval** value. The marker lines shift to the right or left by this value in the chip power graph of the **I/Q Polar & Power Graph** display.
- **Spectrum** - Allows you to toggle the spectrum function between **Normal** and **Invert**. This key, when set to **Invert**, conjugates the spectrum, which equivalently negates the quadrature component in demodulation. The correct setting (**Normal** or **Invert**) depends on whether the signal being input to the instrument has a high or low side mix.
- **Advanced** - Allows you to access the menu to set the following parameters.
 - **Active Set Th** - Allows you to toggle the active channel identification function between **Auto** and **Man**. If set to **Auto**, the active channels are determined automatically by the internal algorithm. If set to **Man**, the active channel identification for each code channel is determined by a user definable threshold ranging from -100.00 dB to 0.00 dB.
 - **Chip Rate** - Allows you to change the chip rate. The range is 1.10592 to 1.35168 MHz.
 - **Phase Compensation** - Allows you to turn the phase compensation function **On** or **Off**. If set to **On**, the measured phase will be compensated slot by slot referenced to pilot channel phase in one slot.
 - **ADC Range** - Allows you to access the following selection menu to define one of the ADC ranging functions:
 - Auto** - Select this to automatically set the ADC range. For most FFT measurements, the auto feature should not be selected. An exception is when measuring a “bursty” signal, in which case **Auto** can maximize the time domain dynamic range, if FFT results are less important to you than time domain results.
 - Auto Peak** - Select this to set the ADC range automatically to the peak signal level. **Auto Peak** is a compromise that works well for both CW and burst signals.
 - Auto Peak Lock** - Select this to hold the ADC range automatically at the peak signal level. **Auto Peak Lock** is more stable than **Auto Peak** for CW signals, but should not be used for “bursty” signals.
 - Manual** - Allows you to access the selection menu of values, -6 through +24 dB for E4406A or None to +18 dB for PSA, to set

the ADC range level. Also note that manual ranging is best for CW signals.

Changing the View

The **View/Trace** key will allow you to select the desired measurement view from the following selections:

- **Power Graph & Metrics** - This is the default selection for the code domain measurement.

Figure 4-11

Code Domain Measurement - Power Graph & Metrics View

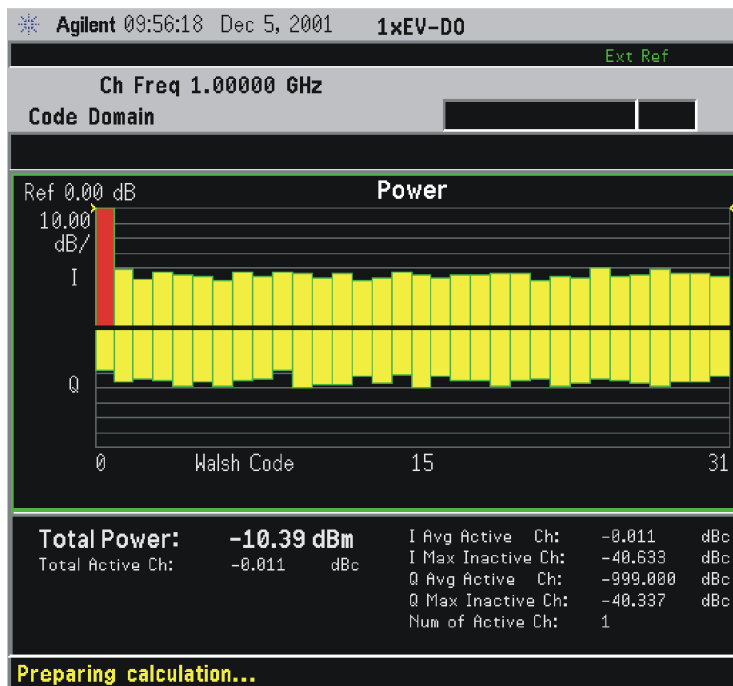

- **I/Q Polar & Power Graph** - Provides a combination view of the code domain power, I/Q symbol polar vector, and chip power graphs as shown in [Figure 4-12](#).

Figure 4-12 Code Domain Measurement - I/Q Polar & Power Graph View

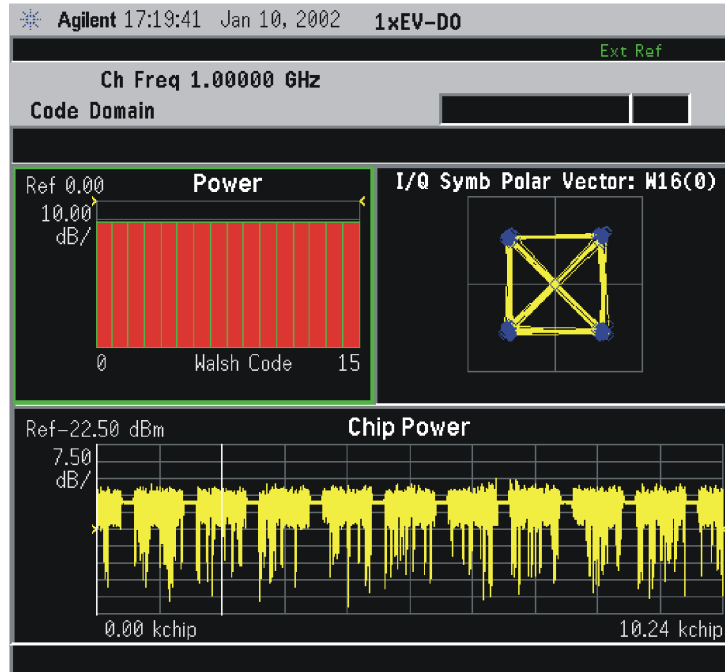

Making Measurements

Changing the Display

The **Display** key access the menu to change the following parameters:

- **Code Order** - Allows you to access the menu to set the Walsh code order to either **Hadamard** or **Bit Reverse**.
- **I/Q Combined Power Bar** - Allows you to toggle the I/Q combined power display function between **On** and **Off**. If set to **On**, the I and Q power bars are consolidated on the upper side of the horizontal axis. If set to **Off**, the I and Q power bars are shown on the upper side and the lower side of the horizontal axis, respectively.

If the **Power** window is active in the **Power Graph & Metrics** or **I/Q Polar & Power Graph** view, the **SPAN X Scale** or **AMPLITUDE Y Scale** key accesses the menu to allow the following settings:

- With the **SPAN X** key:
 - **Scale/Div** - Allows you to set the horizontal scale by changing the value per division. The range is 16.0 to 64.0 Walsh codes per division. The default setting is 64.0.
 - **Ref Value** - Allows you to set the reference value ranging from -640.00 to 640.00. The default setting is 0.00.

- **Ref Position** - Allows you to set the reference value ranging from -640.00 to 640.00. The default setting is 0.00.
- With the **AMPLITUDE Y Scale** key:
 - **Scale/Div** - Allows you to set the vertical scale by changing the value per division. The range is 0.10 to 20.0 dB per division. The default setting is 10.00 dB.
 - **Ref Value** - Allows you to set the reference value ranging from -250.00 to 250.00 dB. The default setting is 0.00 dB.

If **Chip Power** window is active in the I/Q Polar & Power Graph, the **SPAN X Scale** and **AMPLITUDE Y Scale** keys access the following menu:

- With the **SPAN X Scale** key:
 - **Scale/Div** - Allows you to set the horizontal scale by changing a symbol value per division. The range is 0.10 to 5000.00 chips per division with 0.01 resolution. The default setting is 1024.0 chips. However, since the **Scale Coupling** default is **On**, this value is automatically determined by the measurement result. When you set a value manually, **Scale Coupling** automatically changes to **Off**.
 - **Ref Value** - Allows you to set the chip reference value ranging from 0.00 to 50000.00 chips. The default setting is 0.000 chips. However, since the **Scale Coupling** default is **On**, this value is automatically determined by the measurement results. When you set a value manually, **Scale Coupling** automatically changes to **Off**.
 - **Ref Position** - Allows you to set the reference position to either **Left**, **Ctr** (center) or **Right**. The default setting is **Left**.
 - **Scale Coupling** - Allows you to toggle the scale coupling function between **On** and **Off**. The default setting is **On**. Upon pressing the **Restart** front-panel key or the **Restart** softkey under the **Meas Control** menu, this function automatically determines the scale per division and reference values based on the measurement results. When you set a value to either **Scale/Div** or **Ref Value** manually, **Scale Coupling** automatically changes to **Off**.
- With the **AMPLITUDE Y Scale** key:
 - **Scale/Div** - Allows you to set the vertical scale by changing the value per division. The range is 0.10 to 20.00 dB. The default setting is 10.00 dB. However, since the **Scale Coupling** default is **On**, this value is automatically determined by the measurement result. When you set a value manually, **Scale Coupling** automatically changes to **Off**.
 - **Ref Value** - Allows you to set the reference value ranging from -250.00 to 250.00 dB. The default setting is 0.00 dB. However, since the **Scale Coupling** default is **On**, this value is automatically determined by the measurement results. When you set a value

manually, **Scale Coupling** automatically changes to **Off**.

- **Ref Position** - Allows you to set the reference position to either **Top**, **Ctr** (center) or **Bot** (bottom). The default setting is **Ctr**.
- **Scale Coupling** - Allows you to toggle the scale coupling function between **On** and **Off**. The default setting is **On**. Upon pressing the **Restart** front-panel key or the **Restart** softkey under the **Meas Control** menu, this function automatically determines the scale per division and reference values based on the measurement results. When you set a value to either **Scale/Div** or **Ref Value** manually, **Scale Coupling** automatically changes to **Off**.

Using the Markers

The **Marker** front-panel key accesses the menu to configure the markers depending on the display selected.

- **Select 1 2 3 4** - Allows you to activate up to four markers with the corresponding numbers, respectively. The selected number is underlined and its function is defined by pressing the **Function** key. The default setting is 1.
- **Normal** - Allows you to activate the selected marker to read the power level and symbol code with the code layer. The marker position is controlled either by manual adjustment of the RPG knob or by direct entry of the Walsh code number via the front panel keypad.
- **Delta** - Allows you to read the differences in the power levels and symbols codes between the selected marker and the next.
- **Function** - Allows you to set the selected marker function to **Band Power**, **Noise**, or **Off**. The default setting is **Off**. The **Band Power** and **Noise** functions are not available for this measurement.
- **Trace** - Allows you to place the selected marker on the **Code Domain Power** or **Chip Power** trace. The default setting is **Code Domain Power**.
- **Off** - Allows you to turn off the selected marker.
- **Shape** - Allows you to access the menu to set the selected marker shape to **Diamond**, **Line**, **Square**, or **Cross**. The default setting is **Diamond**.
- **Marker All Off** - Allows you to turn off all of the markers.
- **Mkr→Despread** - While a maker is set on any active channel of the code domain power or chip power graph in the **Power Graph and Metrics** or **I/Q Polar & Power Graph** view, this key allows you to observe the Chip Power and the I/Q Symbol Polar Vector graphs with the Walsh code number for that active channel in other windows. The I/Q symbol polar vector graph is displayed for the symbol power specified by the measurement interval and measurement offset.

The front panel **Search** key performs a peak search when pressed. A marker will automatically be activated at the highest peak.

Troubleshooting Hints

Uncorrelated interference may cause CW interference like local oscillator feedthrough or spurs. Another uncorrelated noise may be due to I/Q modulation impairments. Correlated impairments can be due to the phase noise on the local oscillator in the upconverter or I/Q modulator of the UUT. These will be analyzed by the code domain measurements along with the QPSK EVM measurements and others.

A poor phase error indicates a problem at the I/Q baseband generator, filters, and/or modulator in the transmitter circuitry of the UUT. The output amplifier in the transmitter can also create distortion that causes unacceptably high phase error. In a real system, a poor phase error will reduce the ability of a receiver to correctly demodulate the received signal, especially in marginal signal conditions.

Making the Reverse Link Code Domain Measurement

This section describes making MS tests, also known as reverse link tests. If you are going to make BTS tests or forward link tests, see [“Making the Forward Link Code Domain Measurement” on page 170](#).

Purpose

Since the code domain measurements despread and descramble the 1xEV-DO signal into its physical channels, the number of active channels of various symbol rates (which are denoted by widths) can be observed. The width of the channel is inversely proportional to the Walsh code length in number of bits. In the code domain, there is a fixed amount of code space for a given chip rate. Therefore, by using the different Walsh codes, the system can dynamically allocate the code space for lower rate voice users versus high speed data users.

This code domain power composite view provides information about the in-channel characteristics of the 1xEV-DO signal. It directly informs the user of the active channels with their individual channel powers. The composite view also shows which data rates are active and the corresponding amount of code space used. The following are conditions under which a general unlock can occur: the Pilot signal is too low in power or no Pilot signal available, an incorrect long code is used for despreading, the frequency error is too large, or a frequency inversion is present.

When the level of the code domain noise floor is too high, relative to a reference or an expected level, one of the possible causes might be due to CW interference, like local oscillator feedthrough or spurs. I/Q modulation impairments can be another source of this uncorrelated noise. The I/Q demodulation measurements can reveal errors such as I/Q gain imbalance or I/Q quadrature error.

Measurement Method

This procedure measures the power levels of the spread channels in composite RF channels. **Measure** in the **Meas Control** menu default is **Single** for this measurement.

The code domain measurement displays the power for each of the spread channels, relative to the total power within the 1.230 MHz channel bandwidth centered at the center frequency. Each spread channel level is displayed as an individual vertical bar with a different width determined by a spread rate. Because this is a relative measurement, the unit of measure is dB (not dBm or watts). This allows a comparison of signal levels between the Pilot and Traffic

channels.

The demodulated I and Q signals are individually shown in the code domain power graph window. Depending on the test equipment for MS, it is recommended that you use the trigger output signal from the instrument for synchronization.

The following displays are available for this measurement:

- Power Graph & Metrics - The transmitted energy associated with each of the symbol rates and Walsh codes is shown in the graph window. The following powers along with the total absolute power are shown in the text window:
 - Total active channel power
 - Pilot channel power
 - I average active channel power
 - I maximum inactive channel power
 - Q average active channel power
 - Q maximum inactive channel power
 - Number of active channels
- I/Q Error (Quad View) - The magnitude error, phase error, and EVM graphs are individually shown in the graph windows. The summary results associated with these parameters are also shown in the text window.
- Code Domain (Quad View) - The graphs of the code domain power, the symbol power for the selected Walsh code numbers, and the I/Q symbol polar vector for the symbol range selected by the measurement interval and measurement offset parameters, are shown in the graph windows. The summary results associated with these parameters are also shown in the text window.
- Demod Bits - In addition to the graphs of the code domain power and the symbol power for the selected spread channel, the demodulated bit stream data can be shown for the selected slots of the symbol power in the text window.

Making the Measurement

NOTE

The factory default settings provide a 3GPP2 compliant measurement. For special requirements, you may need to change some of the settings. Press **Meas Setup**, **More**, **Restore Meas Defaults** at any time to return all parameters for the current measurement to their default settings.

Select the desired center frequency as described in [“Changing the Frequency Channel”](#) on page 77.

For PSA with Option 1DS Internal Preamplifier, see “[Configuring the Input Condition](#)” on page 72 for details of **In Preamp** and **Attenuator** operation.

Press **MEASURE, Code Domain** to immediately make a code domain power measurement. This section describes making MS tests, also known as reverse link tests. If you are going to make BTS tests or forward link tests, see “[Making the Forward Link Code Domain Measurement](#)” on page 170.

To change any of the measurement parameters from the factory default values, refer to “[Changing the Measurement Setup](#)” on page 184.

Results

The next figure shows an example result of a Code Domain Power measurement. In the graph window, the active channels are highlighted and the Walsh code numbers are shown with the horizontal position with those heights for the measured power levels. In addition to the total power, powers for total active channels, pilot channel, I average active and maximum inactive channel powers, Q average active and maximum inactive channel powers, and the number of active channels, are shown in the text window.

Figure 4-13

Code Domain Measurement - Power Graph View

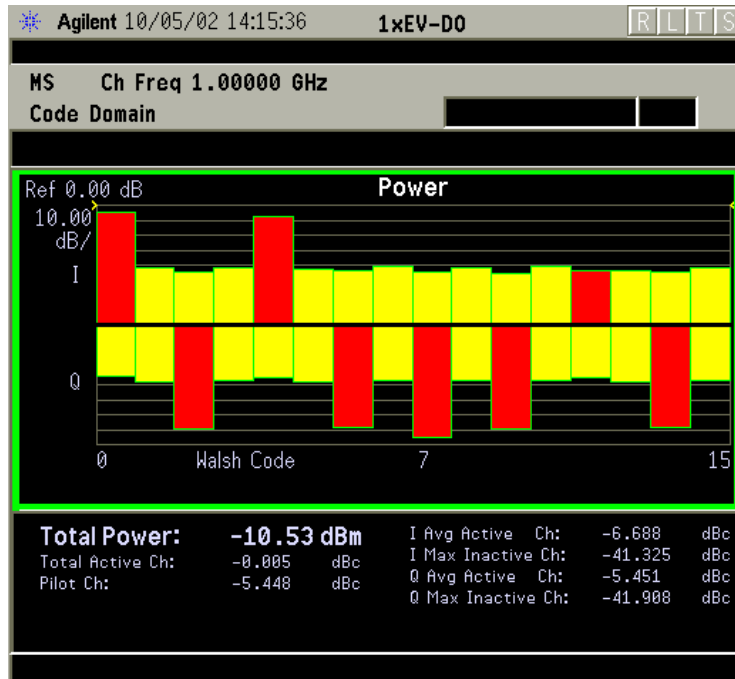

*Meas Setup: Factory default settings

*Input signal: -10.00 dBm, 1xEV-DO

Changing the Measurement Setup

The next table shows the factory default settings for code domain power measurements.

Table 4-10 Code Domain Power Measurement Defaults

Measurement Parameter	Factory Default Condition
View/Trace	Power Graph & Metrics
Display:	
Code Order	Hadamard
Consolidated Marker	On
Meas Setup:	
Meas Type	Rel (relative)
Walsh Code Length	16
Walsh Code Number	0
I/Q Branch	I
Meas Interval	1.0 slots
Meas Offset	0.0 slots
I Long Code Mask	0
Q Long Code Mask	0
Active Code Chan	Auto
Predefined Active Chan	(unless Active Code Chan is Auto)
Capture Intvl	5 slots
Trig Source	Free Run (Immediate)
Spectrum	Normal
Meas Control:	
Measure	Single
Advanced	
Active Set Th	Auto; ---- dB
Chip Rate	1.228800 MHz
ADC Range:	
Manual	-6 dB (for E4406A), None (for PSA)

Make sure the **Code Domain** measurement is selected under the **MEASURE** menu. Press the **Meas Setup** key to access the menu which allows you to modify the trigger source for this measurement as described in “[Measurement Setup](#)” on page 127. Also, press the **Meas Control** key to access the menu which allows you to change **Measure**

from **Single** to **Cont** (continuous) as described in “[Measurement Control](#)” on page 126.

In addition, the following parameters can be changed according to your measurement requirement:

- **Meas Type** - Allows you to toggle the code domain power measurement type between **Rel** (relative) and **Abs** (absolute). If set to **Rel**, the measurement is made in the relative power in dBc. If set to **Abs**, the measurement is made in the absolute power in dBm.
- **Walsh Code Length** - Allows you to set the Walsh code length to either 4, 8, or 16. The parameter automatically sets the maximum value for **Walsh Code Number** when appropriate. If **Walsh Code Length** is set to 16 and **Walsh Code Number** is set to 0, the Pilot channel is automatically selected as the channel type.
- **Walsh Code Number** - Allows you to set the Walsh code number. The range is 0 to (**Walsh Code Length** – 1).
- **I/Q Branch** - Allows you to toggle the selection of the I/Q branch signals between **I** and **Q**. The default selection is **I**.
- **Meas Interval** - Allows you to set the time interval in slots over which the symbol power measurement is made. The range is 0.0 to the slots defined by **Capture Interval**. The marker lines reflecting this value are displayed in the symbol power graph of the **Code Domain (Quad View)** and **Demod Bits** displays. Refer to the illustration in **Meas Offset** below.
- **Meas Offset** - Allows you to set the number of offset slots to make a symbol power measurement. The range is 0 to **Capture Intvl** – 0.5 slots. The summation of **Meas Interval** and **Meas Offset** should be less than 32 slots. The marker lines shift left or right by this value in the symbol power graph of the **Code Domain (Quad View)** and **Demod Bits** displays. The following illustration shows the relationship between the capture interval and the measurement interval.

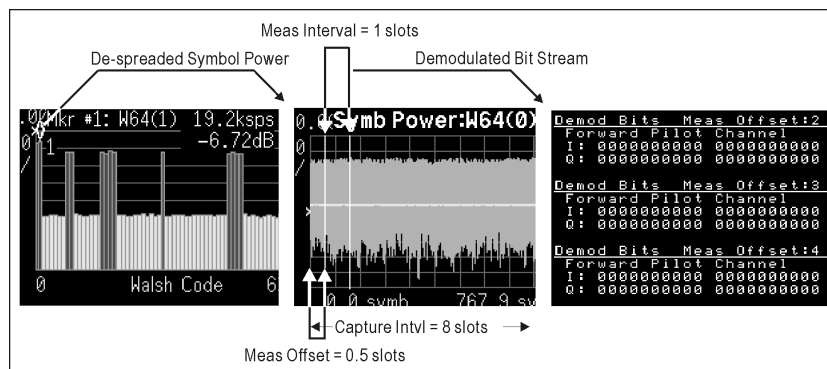

- **I Long Code Mask** - Allows you to set the long code mask value for the I signal. The value ranges from 0x0 to 0x3FFFFFFFFFFF (42 bits). This value is used in the long code generation process.

- **Q Long Code Mask** - Allows you to set the long code mask value for the Q signal. The value ranges from 0x0 to 0x3FFFFFFFFFFFF (42 bits). This value is used in the long code generation process.
- **Active Code Chan** - Allows you to access the menu of the following active channel identification functions.
 - **Auto** - Sets to automatically detect the active code channel(s). If the input power level is not stable, this detection method may not be effective.
 - **Combination** - Sets to use the active channels combined with the predefined active channel and those detected by the auto active channel detection function.
 - **Predefined** - Allows you to use the active code channels defined by the **Predefined Active Chan** key.
- **Predefined Active Chan** - Allows you to access the menu of the following channels for enabling each channel active or inactive. This key is disabled when **Active Code Chan** is set to **Auto**.
 - **Pilot Chan (W16(0):I)** - Allows you to toggle the pilot channel activation between **On** (active) and **Off** (inactive).
 - **DRC Chan (W16(8):Q)** - Allows you to toggle the DRC (data rate control) channel activation between **On** (active) and **Off** (inactive).
 - **Ack Chan (W8(4):I)** - Allows you to toggle the acknowledge channel activation between **On** (active) and **Off** (inactive).
 - **Data Chan (W4(2):Q)** - Allows you to toggle the data channel activation between **On** (active) and **Off** (inactive).
- **Capture Intvl** - Allows you to set the number of power control groups to make a symbol power measurement. The range is 2 to 32 slots in conjunction with the **Meas Interval** value. The maximum value is (32 – **Meas Interval**). The marker lines shift to the right or left by this value in the symbol power graph of the **Code Domain (Quad View)** and **Demod Bits** display.
- **Spectrum** - Allows you to toggle the spectrum function between **Normal** and **Invert**. This key, when set to **Invert**, conjugates the spectrum, which equivalently negates the quadrature component in demodulation. The correct setting (**Normal** or **Invert**) depends on whether the signal being input to the instrument has a high or low side mix.
- **Advanced** - Allows you to access the menu to set the following parameter.
 - **Chip Rate** - Allows you to change the chip rate. The range is 1.10592 to 1.35168 MHz.
 - **Active Set Th** - Allows you to toggle the active channel

identification function between **Auto** and **Man**. If set to **Auto**, the active channels are determined automatically by the internal algorithm. If set to **Man**, the active channel identification for each code channel is determined by a user definable threshold ranging from -100.00 to 0.00 dB.

- **ADC Range** - Allows you to access the following selection menu to define one of the ADC ranging functions:
 - Auto** - Select this to automatically set the ADC range. For most FFT measurements, the auto feature should not be selected. An exception is when measuring a “bursty” signal, in which case **Auto** can maximize the time domain dynamic range, if FFT results are less important to you than time domain results.
 - Auto Peak** - Select this to set the ADC range automatically to the peak signal level. **Auto Peak** is a compromise that works well for both CW and burst signals.
 - Auto Peak Lock** - Select this to hold the ADC range automatically at the peak signal level. **Auto Peak Lock** is more stable than **Auto Peak** for CW signals, but should not be used for “bursty” signals.
 - Manual** - Allows you to access the selection menu of values, -6 to $+24$ dB for E4406A or None to $+18$ dB for PSA, to set the ADC range level. Also note that manual ranging is best for CW signals.

Changing the View

The **View/Trace** key will allow you to select the desired view of the measurement from the following. Each of these views contains multiple windows that can be selected by the **Next Window** key and made full size using the **Zoom** key.

- **Power Graph & Metrics** - Provides a combination view of the code domain power graph and the summary data as shown in [Figure 4-13 on page 183](#).
- **I/Q Error (Quad View)** - Provides a combination view of the magnitude error, phase error, and EVM graphs, and the summary data for the code number, rms and peak EVM's, magnitude error, phase error, absolute total power, and channel power in the text window as shown in [Figure 4-14](#).

Figure 4-14 Code Domain Measurement - I/Q Error Quad View

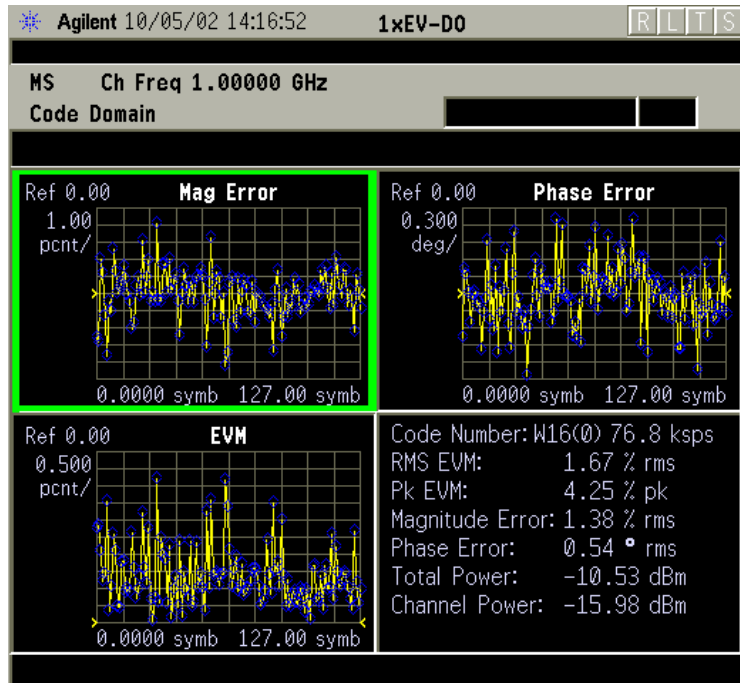

*Meas Setup: View/Trace = I/Q Error (Quad View),
 Others = Factory default settings

*Input signal: -10.00 dBm, 1xEV-DO

- **Code Domain (Quad View)** - Provides a combination view of the code domain power, symbol power, and I/Q symbol power polar vector graphs in the graph window, and the summary data for the code number, rms and peak EVM's, magnitude error, phase error, absolute total power, and channel power in the text window as shown in [Figure 4-15](#).

Figure 4-15 Code Domain Measurement - Code Domain Quad View

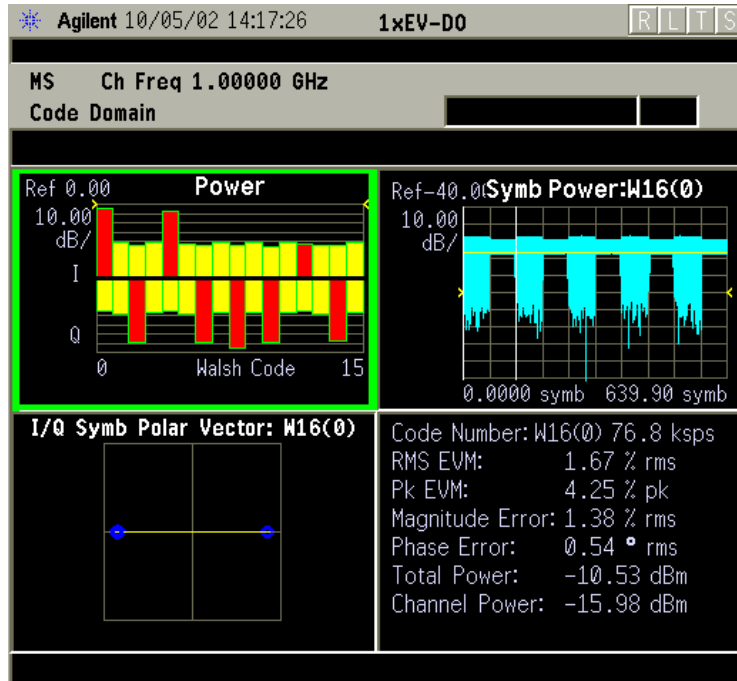

*Meas Setup: View/Trace = Code Domain (Quad View),
 Others = Factory default settings

*Input signal: -10.00 dBm, 1xEV-DO

- **Demod Bits** - Provides a combination view of the code domain power and symbol power graphs, and the I/Q demodulated bit stream data with the corresponding slot or measure offset number in the power control groups, in the text window as shown in [Figure 4-16](#).

Figure 4-16 Code Domain Measurement - Demod Bits View

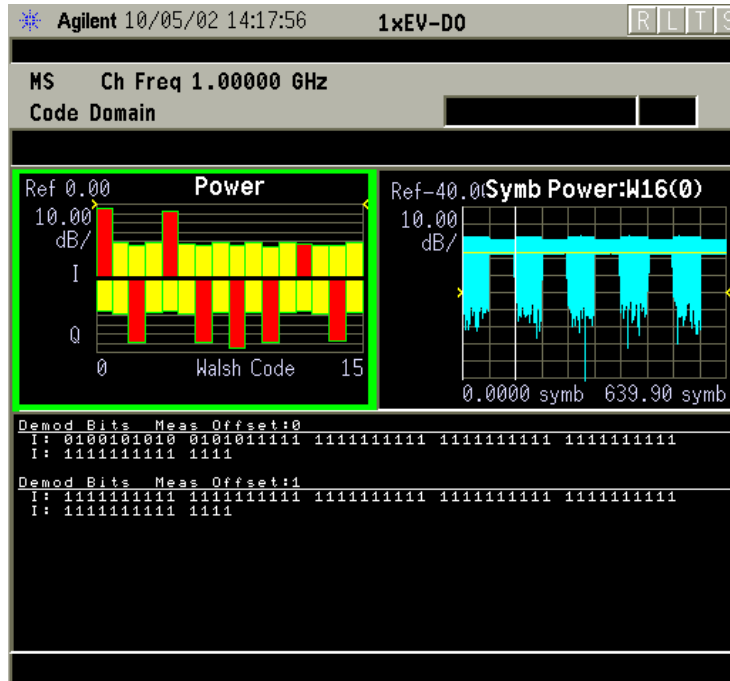

*Meas Setup: View/Trace = Demod Bits,
 Others = Factory default settings

*Input signal: -10.00 dBm, 1xEV-DO

While the Code Domain Power graph is active, press the **Marker** key to place a marker on any active spread channel. Then, press the **Mkr->Despread** key to observe the Symbol Power and the I/Q Symbol Polar Vector graphs with the Walsh code number for that active channel in other graph windows. The I/Q symbol polar vector graph and the demodulated bit stream are displayed for the symbol power specified by the measurement interval and measurement offset.

Changing the Display

To change the display parameters, the **Display**, **SPAN X Scale**, and **AMPLITUDE Y Scale** keys are available, depending on the window selected.

In symbol power measurements in the code domain, phase trajectories between constellation points are not significant to the measurement. Therefore, by default, the points per chip is always set to 1 and the chip dots is set to On.

If the Power graph window is active in the **Power Graph & Metrics**, **Code Domain (Quad View)**, or **Demod Bits** view, the **Display** key accesses the menu to allow the following settings:

- **Code Order** - Allows you to access the menu to set the Walsh code order to one of the following parameters.

- **Hadamard** - Sets the Walsh code order function to the Hadamard format. The next figure shows code domain power graphs for Walsh Code 4 and OVSF Code 4 to illustrate their relationship. This is the default setting.

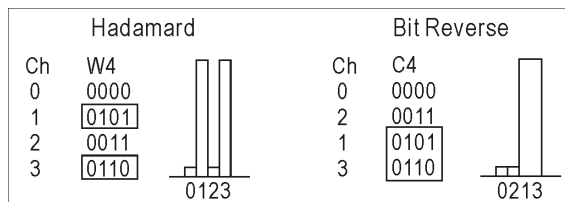

- **Bit Reverse** - Sets the Walsh code order to the bit reversed format.

- **Consolidated Marker** - Allows you to toggle the consolidated marker function between **On** and **Off**. If set to **On**, the corresponding Walsh code channel power will be marked in the different color upon placing the marker at the consolidated Walsh code channel power. The default setting is **On**. The **Consolidated Marker** key is disabled when **Code Order** is set to **Bit Reverse**.

If the **Symbol Power** window is active in the **Code Domain (Quad View)** or **Demod Bits**, the **Display** key accesses the menu to allow the following settings:

- **Composite Chip Power** - Allows you to toggle the composite chip power display function between **On** and **Off**. The default setting is **On**.

If the **Demod Bits** window is active in the **Demod Bits** view, the **Display** key accesses the menu to allow the following controls to read the bit stream measurement results:

- **Prev Page** - Returns one page back to the previous page of the measurement results.
- **Next Page** - Moves one page forward to the following page of the measurement results.
- **Scroll Up** - Moves one line upward on the current page of the measurement results by each pressing.
- **Scroll Down** - Moves one line downward on the current page of the measurement results by each pressing.
- **First Page** - Moves from the current page to the first page of the measurement results.
- **Last Page** - Moves from the current page to the last page of the measurement results.

If the **Power** window is active in the **Power Graph & Metrics, Code Domain (Quad View)**, or **Demod Bits** view, the **AMPLITUDE Y Scale** key accesses the menu to allow the following settings:

- With the **AMPLITUDE Y Scale** key:

- **Scale/Div** - Allows you to set the vertical scale by changing the value per division. The range is 0.10 to 20.0 dB per division. The default setting is 10.00 dB.
- **Ref Value** - Allows you to set the reference value ranging from -250.00 to 250.00 dB. The default setting is 0.00 dB.

If Symbol Power window is active, the **SPAN X Scale** and **AMPLITUDE Y Scale** keys access the following menu:

- With the **SPAN X Scale** key:
 - **Scale/Div** - Allows you to set the horizontal scale by changing a symbol value per division. The range is 0.10 to 5000.00 symbols per division with 0.01 resolution. The default setting is 11.90 symbols. However, since the **Scale Coupling** default is **On**, this value is automatically determined by the measurement result. When you set a value manually, **Scale Coupling** automatically changes to **Off**.
 - **Ref Value** - Allows you to set the symbol reference value ranging from 0.00 to 50000.00 symbols. The default setting is 0.000 symbol. However, since the **Scale Coupling** default is **On**, this value is automatically determined by the measurement results. When you set a value manually, **Scale Coupling** automatically changes to **Off**.
 - **Ref Position** - Allows you to set the reference position to either **Left**, **Ctr** (center) or **Right**. The default setting is **Left**.
 - **Scale Coupling** - Allows you to toggle the scale coupling function between **On** and **Off**. The default setting is **On**. Upon pressing the **Restart** front-panel key or the **Restart** softkey under the **Meas Control** menu, this function automatically determines the scale per division and reference values based on the measurement results. When you set a value to either **Scale/Div** or **Ref Value** manually, **Scale Coupling** automatically changes to **Off**.
- With the **AMPLITUDE Y Scale** key:
 - **Scale/Div** - Allows you to set the vertical scale by changing the value per division. The range is 0.10 to 20.00 dB. The default setting is 10.00 dB. However, since the **Scale Coupling** default is **On**, this value is automatically determined by the measurement result. When you set a value manually, **Scale Coupling** automatically changes to **Off**.
 - **Ref Value** - Allows you to set the reference value ranging from -250.00 to 250.00 dB. The default setting is 0.00 dB. However, since the **Scale Coupling** default is **On**, this value is automatically determined by the measurement results. When you set a value manually, **Scale Coupling** automatically changes to **Off**.
 - **Ref Position** - Allows you to set the reference position to either **Top**,

Ctr (center) or **Bot** (bottom). The default setting is **Ctr**.

- **Scale Coupling** - Allows you to toggle the scale coupling function between **On** and **Off**. The default setting is **On**. Upon pressing the **Restart** front-panel key or the **Restart** softkey under the **Meas Control** menu, this function automatically determines the scale per division and reference values based on the measurement results. When you set a value to either **Scale/Div** or **Ref Value** manually, **Scale Coupling** automatically changes to **Off**.

If either EVM, Phase Error, or Mag Error window is active in the **I/Q Error (Quad View)** view, the **SPAN X Scale** key accesses the menu to allow the following settings:

- **Scale/Div** - Allows you to set the horizontal scale by changing a symbol value per division. The range is 0.10 to 5000.00 symbols per division with 0.01 symbol resolution. The default setting is 1.900 symbols. However, since the **Scale Coupling** default is **On**, this value is automatically determined by the measurement result. When you set a value manually, **Scale Coupling** automatically changes to **Off**.
- **Ref Value** - Allows you to set the symbol reference value ranging from 0.00 to 50000.0 symbols. The default setting is 0.00 symbol. However, since the **Scale Coupling** default is **On**, this value is automatically determined by the measurement results. When you set a value manually, **Scale Coupling** automatically changes to **Off**.
- **Ref Position** - Allows you to set the reference position to either **Left**, **Ctr** (center) or **Right**. The default setting is **Left**.
- **Scale Coupling** - Allows you to toggle the scale coupling function between **On** and **Off**. The default setting is **On**. Upon pressing the **Restart** front-panel key or the **Restart** softkey under the **Meas Control** menu, this function automatically determines the scale per division and reference values based on the measurement results. When you set a value to either **Scale/Div** or **Ref Value** manually, **Scale Coupling** automatically changes to **Off**.

If either EVM or Mag Error window is active in the **I/Q Error (Quad View)** view, the **AMPLITUDE Y Scale** key accesses the menu to allow the following settings:

- **Scale/Div** - Allows you to set the vertical scale by changing the value per division. The range is 0.100 to 50.0% per division. The default setting is 15.00%. However, since the **Scale Coupling** default is **On**, this value is automatically determined by the measurement result. When you set a value manually, **Scale Coupling** automatically changes to **Off**.
- **Ref Value** - Allows you to set the reference value ranging from -500.00 to 500.0%. The default setting is 0.00%. However, since the **Scale Coupling** default is **On**, this value is automatically determined by the measurement results. When you set a value manually, **Scale**

Coupling automatically changes to **Off**.

- **Ref Position** - Allows you to set the reference position to either **Top**, **Ctr** (center) or **Bot** (bottom). For the EVM graph, the default setting is **Bot**. For the Mag Error graph, the default setting is **Ctr**.
- **Scale Coupling** - Allows you to toggle the scale coupling function between **On** and **Off**. The default setting is **On**. Upon pressing the **Restart** front-panel key or the **Restart** softkey under the **Meas Control** menu, this function automatically determines the scale per division and reference values based on the measurement results. When you set a value to either **Scale/Div** or **Ref Value** manually, **Scale Coupling** automatically changes to **Off**.

If the Phase Error window is active in the **I/Q Error (Quad View)** view, the **AMPLITUDE Y Scale** key accesses the menu to allow the following settings:

- **Scale/Div** - Allows you to set the vertical scale by changing the value per division. The range is 0.0100 to 3600.0 degrees. The default setting is 5.00 degrees. However, since the **Scale Coupling** default is **On**, this value is automatically determined by the measurement result. When you set a value manually, **Scale Coupling** automatically changes to **Off**.
- **Ref Value** - Allows you to set the reference value ranging from -36000.0 to 36000.0 degrees. The default setting is 0.00 degrees. However, since the **Scale Coupling** default is **On**, this value is automatically determined by the measurement results. When you set a value manually, **Scale Coupling** automatically changes to **Off**.
- **Ref Position** - Allows you to set the reference position to either **Top**, **Ctr** (center) or **Bot** (bottom). The default setting is **Ctr**.
- **Scale Coupling** - Allows you to toggle the scale coupling function between **On** and **Off**. The default setting is **On**. Upon pressing the **Restart** front-panel key or the **Restart** softkey under the **Meas Control** menu, this function automatically determines the scale per division and reference values based on the measurement results. When you set a value to either **Scale/Div** or **Ref Value** manually, **Scale Coupling** automatically changes to **Off**.

Using the Print Function

In addition to the normal menu of the **Print Setup** front-panel key, one selection key is added to configure the print function if **View/Trace** is set to **Demod Bits**.

- **Print Demod** - Allows you to toggle the print function between **Screen** and **Report**. The default setting is **Screen** to dump a screen image. To create a text file of the demodulated data bits, press **Print Setup**, **HCOPY Dest**, select = **Print To Key**, and toggle the **Print Demod** key to

Report. A text file named “demodbit.txt” will be written to the destination drive selected.

Using the Markers

The **Marker** front-panel key accesses the menu to configure the markers depending on the display selected.

- **Select** - Allows you to activate up to four markers with the corresponding numbers, respectively. The selected number is underlined and its function is defined by pressing the **Function** key. The default setting is 1.
- **Normal** - Allows you to activate the selected marker to read the power level and symbol code with the code layer. The marker position is controlled either by manual adjustment of the RPG knob or by direct entry of the Walsh code number via the front panel keypad.
- **Delta** - Allows you to read the differences in the power levels and symbols codes between the selected marker and the next.
- **Function** - Allows you to set the selected marker function to **Band Power**, **Noise**, or **Off**. The default setting is **Off**. The **Band Power** and **Noise** functions are not available for this measurement.
- **Trace** - Allows you to place the selected marker on the **Code Domain Power**, **Symbol Power**, **Chip Power**, **EVM**, **Phase Error**, or **Mag Error** trace. The default setting is **Code Domain Power**.
- **Off** - Allows you to turn off the selected marker.
- **Shape** - Allows you to access the menu to set the selected marker shape to **Diamond**, **Line**, **Square**, or **Cross**. The default setting is **Diamond**.
- **Marker All Off** - Allows you to turn off all of the markers.
- **Mkr→Despread** - While a maker is set on any active spread channel of the code domain power graph in the **Power Graph and Metrics**, **Code Domain (Quad View)**, or **Demod Bits** view, this key allows you to observe the Symbol Power and the I/Q Symbol Polar Vector graphs with the Walsh spread code number for that active channel in other windows. The I/Q symbol polar vector graph is displayed for the symbol power specified by the measurement interval and measurement offset.

The front panel **Search** key performs a peak search when pressed. A marker will automatically be activated at the highest peak.

Troubleshooting Hints

Uncorrelated interference may cause CW interference like local oscillator feedthrough or spurs. Another uncorrelated noise may be due

to I/Q modulation impairments. Correlated impairments can be due to the phase noise on the local oscillator in the upconverter or I/Q modulator of the UUT. These will be analyzed by the code domain measurements along with the QPSK EVM measurements and others.

A poor phase error indicates a problem at the I/Q baseband generator, filters, and/or modulator in the transmitter circuitry of the UUT. The output amplifier in the transmitter can also create distortion that causes unacceptably high phase error. In a real system, a poor phase error will reduce the ability of a receiver to correctly demodulate the received signal, especially in marginal signal conditions.

Making the Forward Link Modulation Accuracy (Composite Rho) Measurement

This section describes making BTS tests, also known as forward link tests. If you are going to make MS tests or reverse link tests, see [“Making the Reverse Link Modulation Accuracy \(Composite Rho\) Measurement”](#) on page 214.

Purpose

Rho is one of the key modulation quality metrics, along with EVM and code domain power. Rho is the ratio of the correlated power in a single coded channel to the total signal power. This is a simplified case of code domain power since this measurement is made on a single coded channel. This measurement takes into account all possible error mechanisms in the entire transmission chain including baseband filtering, I/Q modulation anomalies, filter amplitude and phase non-linearities, and power amplifier distortion. This provides an overall indication of the performance level of the transmitter of the UUT.

Measurement Method

This procedure measures the performance of the transmitter’s modulation circuitry.

In a digitally modulated signal, it is possible to predict what the ideal magnitude and phase of the carrier should be at any time, based on the transmitted data sequence. The transmitter’s modulated signal is compared to an ideal signal vector. The difference between these two vectors is sampled and processed using DSP. Rho values are in the range of 0.000 to 1.000. A value of 1.000 indicates perfect correlation to the reference (high modulation quality). The 1xEV-DO base station standards require that transmitters have a Rho performance of 0.912 or greater.

If the error code 604 “Can not correlate to input signal” is shown, it means that your measurement has failed to find any active channels due to the lack of correlation with the input signal. The input signal level, for example, may need to be adjusted to obtain correlation.

With the Rho measurement, the following data is provided depending

on the selection of channel types used for this measurement:

Chan Type	Measurement Items	Results with example data		
Common for Pilot, MAC, Data	Measured CH	Pilot		
	Rho	0.99946		
Pilot	EVM	3.08%rms		
	EVM	24.27%pk		
MAC	Magnitude Error	3.25%rms		
	Phase Error	1.95°rms		
Data	Freq Error	-0.09 Hz		
	I/Q Origin Offset	-70.13 dB		
Pilot	Pilot Offset	0.83 μs		
	Active Channels	Pilot: 1 MAC: ---- Data: ----		
MAC	Measured CH	MAC		
	(common items)			
Data	Pilot Offset	0.83 μs		
	Active Channels	Pilot: ---- MAC: 2 Data: ----		
Data	Max Mac Inactive Ch	-24.50 dBc at W64(18): Q		
	Measured CH	Data		
Overall	(common items)			
	Pilot Offset	0.83 μs		
Overall	Active Channels	Pilot: ---- MAC: ---- Data: 16		
	Preamble Length	64 MAC Index: 4		
Overall	Max Data Active Ch	-11.50 dBc at W16(3): I		
	Min Data Active Ch	-12.55 dBc at W16(11): Q		
Overall	Measured CH	Overall-1	Overall-2	Pilot
	Rho	0.99876	0.99903	0.99896
Overall	EVM	3.01%rms	3.12%rms	
	EVM	22.53%pk	23.36%pk	
Overall	Magnitude Error	3.12%rms	3.32%rms	
	Phase Error	1.92°rms	1.87°rms	
Overall	Freq Error	-2.39 Hz	-3.09 Hz	
	I/Q Origin Offset	-55.13 dB	-56.13 dB	
Overall	Pilot Offset	0.83 μs		
	Active Channels	Pilot: 1 MAC: 2 Data: 16		
Overall	Preamble Length	64 MAC Index: 4		
	Max Mac Inactive Ch	-26.55 dBc at W64(18): Q		
Overall	Max Data Active Ch	-11.55 dBc at W16(3): I		
	Min Data Active Ch	-12.54 dBc at W16(11): Q		

Making the Measurement

NOTE

The factory default settings provide a 3GPP2 compliant measurement. For special requirements, you may need to change some of the settings. Press **Meas Setup**, **More**, **Restore Meas Defaults** at any time to return all

parameters for the current measurement to their default settings.

Select the desired center frequency as described in “[Changing the Frequency Channel](#)” on page 77.

For PSA with Option 1DS Internal Preamplifier, see “[Configuring the Input Condition](#)” on page 72 for details of **Int Preamp** and **Attenuator** operation.

Press **MEASURE, Mod Accuracy (Composite Rho)** to immediately make a modulation accuracy measurement. This section describes making BTS tests, also known as forward link tests. If you are going to make MS tests or reverse link tests, see “[Making the Reverse Link Modulation Accuracy \(Composite Rho\) Measurement](#)” on page 214.

To change any of the measurement parameters from the factory default values, refer to “[Changing the Measurement Setup](#)” on page 200.

Results

The following figure shows an example result of a I/Q Measured Polar Graph measurement in the graph window. The measured values for Rho, rms and peak EVM, frequency error, I/Q origin offset, number of active channels, and Pilot offset if specified, are shown in the text window.

Figure 4-17

Modulation Accuracy Measurement - I/Q Polar Graph View

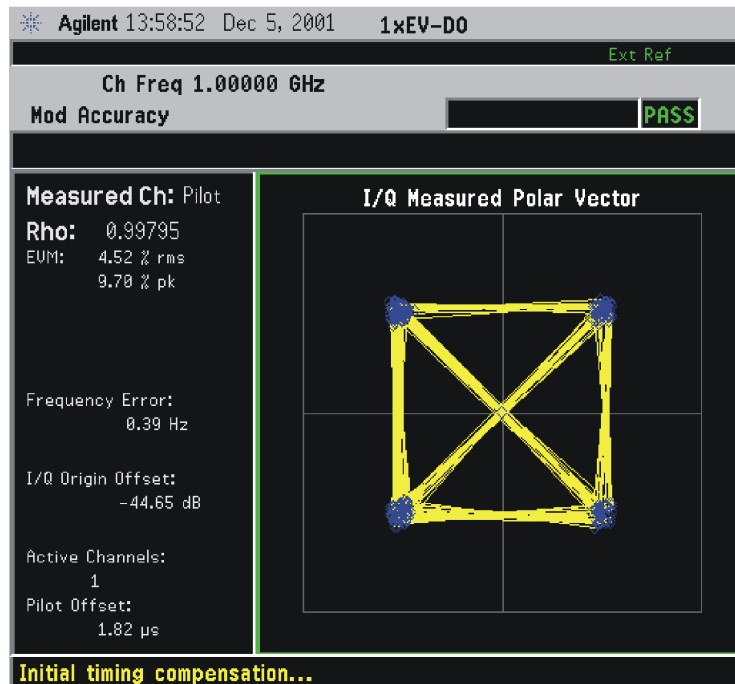

*Meas Setup: Factory default settings

*Input signal: -10.00 dBm, Pilot channel, 1xEV-DO

Changing the Measurement Setup

This table shows the factory default settings for modulation accuracy (composite rho) measurements.

Table 4-11

Modulation Accuracy (Composite Rho) Measurement Defaults

Measurement Parameter	Factory Default Condition
View/Trace	I/Q Measured Polar Graph
Display:	
Chip Offset	0 chips
Chip Interval	2048 chips
Chip Descrambling	Off
Pilot Channel Period	On (grayed out)
MAC Channel Period	Off (grayed out)
Data Channel Period	Off (grayed out)
I/Q Polar Vec/Constln	Vec & Constln
+45 deg Rot	Off
Full Vector (Background)	Off
I/Q Graph Phase Ref	Overall1 (grayed out)
Meas Setup:	
Avg Number	10; On
Avg Mode	Repeat
Channel Type	Pilot
Data Ch Type	QPSK
Preamble Len	---- chips, Auto
Active Data Chan	Auto
PN Offset	0×64 [chips]
Spectrum	Normal
Limits:	
RMS EVM (Composite)	50.0 pcent
Peak EVM (Composite)	100.0 pcent
Rho (Composite)	0.91200
Freq Error	0.05 ppm
Timing	50.0 ns

Table 4-11

Modulation Accuracy (Composite Rho) Measurement Defaults

Measurement Parameter	Factory Default Condition
Phase	0.05 rad
Pilot Offset	10 μ s
Max MAC Inactive Pwr	-27.00 dB
Max Data Active Pwr	-14.56 dB
Min Data Active Pwr	-15.55 dB
Trig Source	Free Run (Immediate)
Advanced	
EVM Result I/Q Offset	Std
Rho Overall Preamble Incl	On
Chip Rate	1.228800 MHz
Multi Channel Estimator	Off
ADC Range: Manual	-6 dB (for E4406A), None (for PSA)
Active Set Th	---- dB; Auto

Make sure the **Mod Accuracy (Composite Rho)** measurement is selected under the **MEASURE** menu. Press the **Meas Setup** key to access a menu which allows you to modify the average number, average mode, and trigger source for this measurement as described in “[Measurement Setup](#)” on page 127. The chip rate is fixed at 1.2288 MHz for SR1 in this measurement.

In addition, the following parameters can be modified according to your measurement requirements:

- **Channel Type** - Allows you to access the menu to specify one of the channel types:
 - **Pilot** - Measurements are made on the pilot channel.
 - **MAC** - Measurements are made on the medium access control (MAC) channel for a full slot.
 - **Data** - Measurements are made on the data channel for a full slot.
 - **Preamble** - Measurements are made on the preamble chips overlaid on the data channel.
 - **Overall** - Measurements are made on all of the channel types for **Rho Overall-1** in the first half slot and **Rho Overall-2** in the second half slot shifted from the first slot as defined in 3GPP2 TSG-4.1.

- **Data Ch Type** - Allows you to access the menu to specify a data type, when **Channel Type** is set to **Data**, otherwise this is disabled.
 - **QPSK** - The data channel type is set to the quadrature phase shift keying.
 - **8PSK** - The data channel type is set to the eight phase shift keying.
 - **16QAM** - The data channel type is set to the sixteen quadrature amplitude modulation.
- **Preamble Len** - Allows you to specify the preamble length in number of chips from the first chip in the data channel, and to toggle the length detection mode between **Auto** and **Man** (manual). If set to **Auto**, the preamble length is automatically detected showing “---- chips” on this key. If set to **Man**, you can enter a value in number of chips to specify the preamble length that is excluded from the data calculation. The selections are 0, 64, 128, 256, 512, and 1024.
- **Active Data Chan** - Allows you to toggle the active channel ID detection between **Auto** and **Predef** (predefined). If set to **Auto**, the active channel ID detection is automatically made for the data channel measurement. If set to **Predef**, the predefined active channel detection is used for the data channel measurement.
- **PN Offset** - Allows you to specify a multiplier for the Walsh code length in the unit of 64 chips. The range is 0 to 511. For example, set a value of 16 from the numeric keypad and press the **Enter** key. PN Offset 16×64 [chips] will be displayed in the screen annotation area. This value corresponds to the time offset between the trigger signal and the external frame signal.
- **Spectrum** - Allows you to toggle the spectrum function between **Normal** and **Invert**. When set to **Invert**, it conjugates the spectrum, which effectively inverts the quadrature component in demodulation. The correct setting (**Normal** or **Invert**) depends on whether the signal being input to the instrument has a high or low side mix.
- **Limits** - Allows you to access the menu to set the following limits:
 - **RMS EVM (Composite)** - Allows you to set the limit for composite RMS EVM measurement result. The range is 0.00 to 50.00%.
 - **Peak EVM (Composite)** - Allows you to set the limit for composite peak EVM measurement result. The range is 0.00 to 100.00%.
 - **Rho (Composite)** - Allows you to set the limit for composite rho measurement result. The range is 0.00000 to 1.00000.
 - **Freq Error** - Allows you to set the limit for peak code domain error measurement result. The range is 0.00 to 1.00 ppm.
 - **Timing** - Allows you to set the limit for timing error from the pilot

channel used in the **Power Timing & Phase** view. The range is 0.0 to 500.0 ns.

- **Phase** - Allows you to set the limit for phase error from the pilot channel used in the **Power Timing & Phase** view. The range is 0.00 to 3.00 rad.
- **Pilot Offset** - Allows you to set the limit for pilot offset time used to offset from the trigger timing. The range is 0.0 to 100.0 μ s.
- **Max MAC Inactive Pwr** - Allows you to set the limit for maximum inactive channel power in the MAC channel. The range is -100.00 to 0.00 dB.
- **Max Data Active Pwr** - Allows you to set the limit for maximum active channel power in the Data channel. The range is -100.00 to 0.00 dB.
- **Min Data Active Pwr** - Allows you to set the limit for minimum active channel power in the Data channel. The range is -100.00 to (**Max Data Active Pwr**) dB.
- **Advanced** - Allows you to access the menu to change the following parameters:
 - **EVM Result I/Q Offset** - Allows you to toggle the I/Q origin offset function between **Std** (standard) and **Exclude**. If set to **Std**, the measurement results for EVM and Rho take into account the I/Q origin offset. If set to **Exclude**, the measurement results for EVM and Rho do not take into account the I/Q origin offset, and the message “Rho excludes I/Q Offset” is displayed in the lower right-side graph display area.
 - **Rho Overall Preamble Incl** - Allows you to toggle the preamble chips inclusion for the rho and rho overall measurements and calculations, between **On** and **Off**. If set to **On**, the rho and its overall-1 and overall-2 results will include the preamble chips. If set to **Off**, the preamble chips are excluded from the rho overall result calculations.
 - **Chip Rate** - Allows you to change the chip rate ranging from 1.10592 to 1.35168 MHz.
 - **Multi Channel Estimator** - Allows you to toggle the multi channel estimator function between **On** and **Off**. When set to **On**, the **Power Timing & Phase** view will be available, and the measurement accuracy will be improved, but measurement speed will be reduced.
 - **ADC Range** - Allows you to access the following selection menu to define one of the ADC ranging functions:
 - **Auto** - Select this to automatically set the ADC range. For most FFT measurements, the auto feature should not be selected.

An exception is when measuring a “bursty” signal, in which case **Auto** can maximize the time domain dynamic range, if FFT results are less important to you than time domain results.

- **Auto Peak** - Select this to set the ADC range automatically to the peak signal level. **Auto Peak** is a compromise that works well for both CW and burst signals.
 - **Auto Peak Lock** - Select this to hold the ADC range automatically at the peak signal level. **Auto Peak Lock** is more stable than **Auto Peak** for CW signals, but should not be used for “bursty” signals.
 - **Manual** - Allows you to access the selection menu of values, –6 dB through +24 dB for E4406A or None through +18 dB for PSA, to set the ADC range level. Also note that manual ranging is best for CW signals.
- **Active Set Th** - Allows you to toggle the active channel identification function between **Auto** and **Man**. If set to **Auto**, the active channels are determined automatically by the internal algorithm. If set to **Man**, the active channel identification for each code channel is determined by a user definable threshold ranging from –100.00 dB to 0.00 dB.

Changing the View

The **View/Trace** key will allow you to select the desired measurement view from the following selections:

- **I/Q Measured Polar Graph** - Provides a combination view of an I/Q measured polar graph and the summary data as shown in [Figure 4-17 on page 199](#).

- **Result Metrics** - One display window shows the measured channel name, rho, EVM, and other errors. The active channel types are also indicated as shown in Figure 4-18.

Figure 4-18

Modulation Accuracy Measurement - Result Metrics View

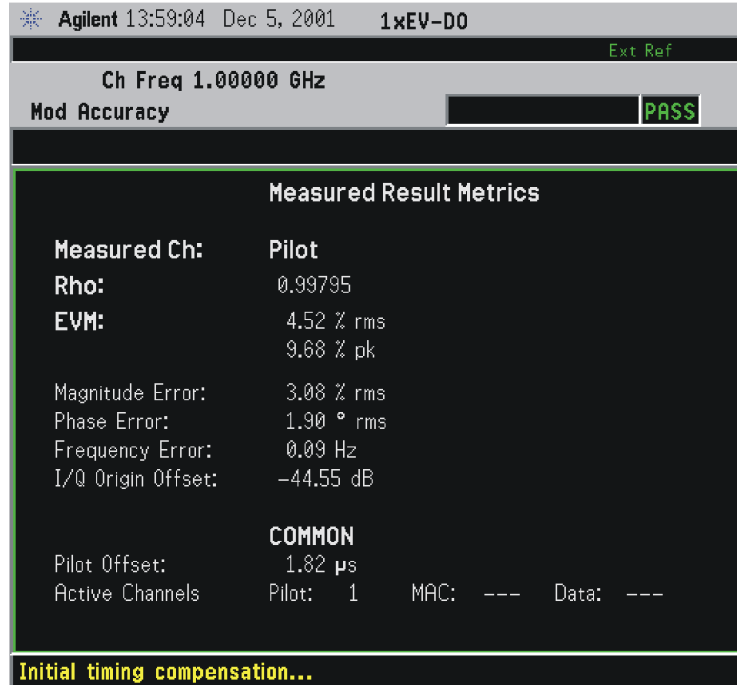

*Meas Setup: View/Trace = Result Metrics
Others = Factory default settings

*Input signal: -10.00 dBm, Pilot channel, 1xEV-DO

Making Measurements

- **I/Q Error (Quad View)** - Four display windows show Mag Error, Phase Error, and EVM graphs, and the summary data for the composite rho, rms and peak EVM, phase error, frequency error, and the active channel types as shown in [Figure 4-19](#).

Figure 4-19 Modulation Accuracy Measurement - I/Q Error Quad View

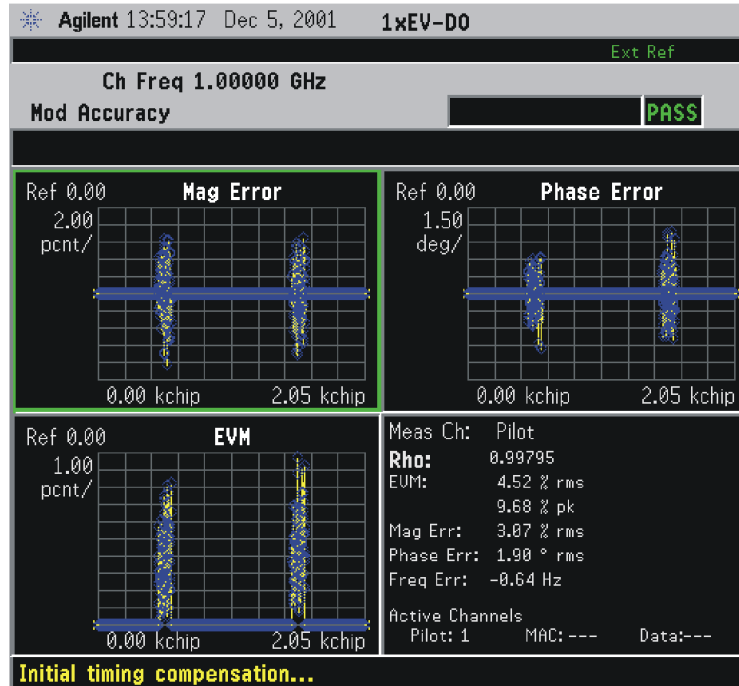

*Meas Setup: View/Trace = I/Q Error (Quad View)
Others = Factory default settings

*Input signal: -10.00 dBm, Pilot channel, 1xEV-DO

Any one of these windows can be selected by the **Next Window** key and made full size using the **Zoom** key.

- **I/Q Measured (Quad View)** - Provides a combination view of an I/Q power vs. chip, I/Q vector absolute power vs. chip, I/Q polar graphs in the graph windows, and the mean power result the summary window as shown in [Figure 4-20](#).

Figure 4-20

Modulation Accuracy Measurement - I/Q Measured Quad View

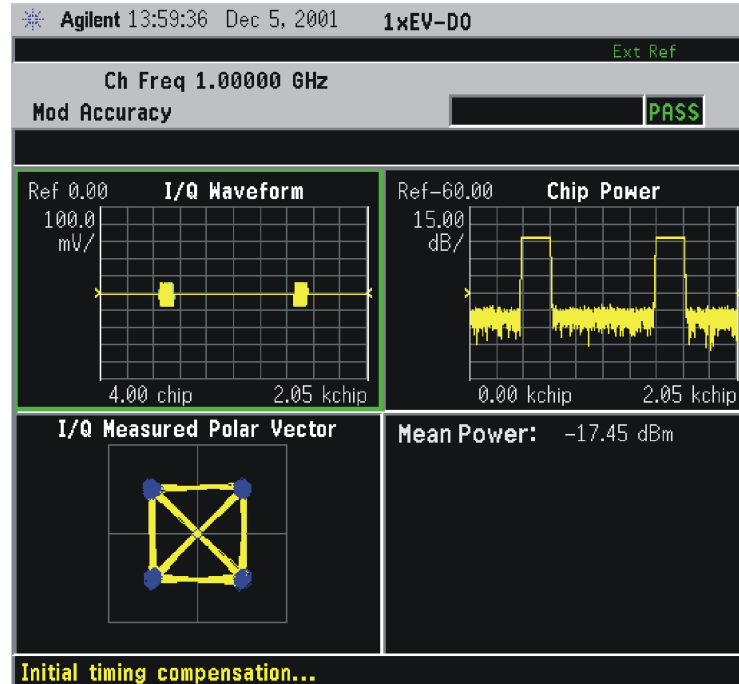

*Meas Setup: View/Trace = I/Q Measured (Quad View),
Channel Type = MAC,
Others = Factory default settings

*Input signal: -10.00 dBm, Pilot & MAC, 1xEV-DO

Any one of these windows can be selected by the **Next Window** key and made full size using the **Zoom** key.

- **Power Timing & Phase** - Provides a measurement result for the active channels with power levels, timing and phase errors in tabular form. Timing and phase are referenced to the Pilot channel as shown in [Figure 4-21](#). To activate this view, press **Meas Setup**, **More**, **Advanced**, and toggle **Multi Channel Estimator** to **On**.

Figure 4-21 Modulation Accuracy Measurement - Power Timing & Phase View

Code	Power(dB)	Timing(ns)	Phase(rad)
C4(0)	-12.05	Reference	Reference
C4(1)	-12.03	2.20	-0.001
C4(2)	-12.04	1.06	0.002
C4(3)	-12.04	-1.75	-0.007
C4(4)	-12.05	0.82	-0.004
C4(5)	-12.04	0.29	0.001
C4(6)	-12.03	0.46	-0.005
C4(7)	-12.04	0.41	-0.009
C4(8)	-12.05	-1.40	-0.002
C4(9)	-12.03	0.74	0.001
C4(10)	-12.05	-2.05	-0.001
C4(11)	-12.03	0.18	-0.001
C4(12)	-12.03	-0.71	-0.002
C4(13)	-12.06	0.33	-0.003
C4(14)	-12.04	1.15	-0.001
C4(15)	-12.04	-0.58	0.002

*Meas Setup: Advanced/Multi Channel Estimator = On,
Channel Type = Data,
View/Trace = Power Timing & Phase,
Others = Factory default settings

*Input signal: -10.00 dBm, Full slot, 1xEV-DO

Changing the Display

The **Display** key accesses the menu which makes the following selections available to change the displays for I/Q Measured Polar Vector, I/Q Measured Polar Constln, and I/Q Error (Quad View):

- **Chip Offset** - Allows you to specify the number of chips offset from the first chip in the captured slot to the displayed first chip. The range is dependent on the **Chip Interval** setting. This offset does not affect the **I/Q Error (Quad View)** display.
- **Chip Interval** - Allows you to specify the number of I/Q chips displayed for the captured I/Q waveforms. This offset does not affect the **I/Q Error (Quad View)** display.

- **Chip Descrambling** - Allows you to toggle the chip display function between **On** and **Off**. If set to **On**, the composite descrambled chips are shown in the polar view. If set to **Off**, the composite scrambled chips are shown in the polar view.
- **Pilot Channel Period** - Allows you to toggle the pilot channel display function between **On** and **Off**. If set to **On**, the polar vectors and constellations take into account the pilot channel in time domain. If set to **Off**, the polar vectors and constellations do not include the pilot channel in time domain. This is grayed out if **Chip Descrambling** is set to **Off**.
- **MAC Channel Period** - Allows you to toggle the medium access control (MAC) channel display function between **On** and **Off**. If set to **On**, the polar vectors and constellations take into account the MAC channel in time domain. If set to **Off**, the polar vectors and constellations do not include the MAC channel in time domain. This is grayed out if **Chip Descrambling** is set to **Off**.
- **Data Channel Period** - Allows you to toggle the data channel display function between **On** and **Off**. If set to **On**, the polar vectors and constellations take into account the data channel in time domain. If set to **Off**, the polar vectors and constellations do not include the data channel in time domain. This is grayed out if **Chip Descrambling** is set to **Off**.
- **I/Q Polar Vec/Constln** - Allows you to select one display with **Vec & Constln** (vector and constellation), **Vec** (vector), or **Constln** (constellation). This key does not affect the **I/Q Error (Quad View)** display.
- **+45 deg Rot** - Allows you to toggle the display rotation function between **On** and **Off**. If this is set to **On**, the I/Q polar vector or constellation graph is rotated by +45 degrees to see a rectangular display. The default setting is **Off**. This key does not affect the **I/Q Error (Quad View)** display.
- **Full Vector (Background)** - Allows you to toggle the full vector display function between **On** and **Off**. If set to **On**, the full vector traces in gray color are displayed in the background of the polar vector solid traces in yellow. The default setting is **Off**. If **View/Trace** is set to **I/Q Measured Polar Constln**, this key is grayed out. This key does not affect the **I/Q Error (Quad View)** display.
- **I/Q Graph Phase Ref** - Allows you to toggle the phase reference of the polar graph between **Overall 1** and **Overall 2**. If set to **Overall 1**, the rho measurement will be made between the 0 chips to 512 chips of the first half slot. If set to **Overall 2**, the measurement will be done from 513 chips through 1023 chips. Select either of these references to make a stable measurement. This is grayed out if **Chip Descrambling** is set to **Off**.

If either EVM, Phase Error, Mag Error, I/Q Waveform, or Chip Power

window is active in the **I/Q Error (Quad View)** or **I/Q Measured (Quad View)** view, the **SPAN X Scale** key accesses the menu to allow the following settings:

- **Scale/Div** - Allows you to set the horizontal scale by changing a chip value per division. The range is 0.00 to 500000.00 chips per division with 0.01 chip resolution. The default setting is 204.7 chips per division. However, since the **Scale Coupling** default is **On**, this value is automatically determined by the measurement result. When you set a value manually, **Scale Coupling** automatically changes to **Off**.
- **Ref Value** - Allows you to set the chip reference value ranging from 0.00 to 5000000.0 chips. The default setting is 0.00 chip. However, since the **Scale Coupling** default is **On**, this value is automatically determined by the measurement results. When you set a value manually, **Scale Coupling** automatically changes to **Off**.
- **Ref Position** - Allows you to set the reference position to either **Left**, **Ctr** (center) or **Right**. The default setting is **Left**.
- **Scale Coupling** - Allows you to toggle the scale coupling function between **On** and **Off**. The default setting is **On**. Upon pressing the **Restart** front-panel key or the **Restart** softkey under the **Meas Control** menu, the scale coupling function automatically determines the scale per division and reference values based on the measurement results. When you set a value to either **Scale/Div** or **Ref Value** manually, **Scale Coupling** automatically changes to **Off**.

If either **EVM** or **Mag Error** window is active in the **I/Q Error (Quad View)** view, the **AMPLITUDE Y Scale** key accesses the menu to allow the following settings:

- **Scale/Div** - Allows you to set the vertical scale by changing the value per division. The range is 0.100 to 50.0% per division. The default setting is 5.00%. However, since the **Scale Coupling** default is **On**, this value is automatically determined by the measurement result. When you set a value manually, **Scale Coupling** automatically changes to **Off**.
- **Ref Value** - Allows you to set the reference value ranging from 0.00 to 500.0%. The default setting is 0.00%. However, since the **Scale Coupling** default is **On**, this value is automatically determined by the measurement results. When you set a value manually, **Scale Coupling** automatically changes to **Off**.
- **Ref Position** - Allows you to set the reference position to either **Top**, **Ctr** (center) or **Bot** (bottom). For the **EVM** graph, the default setting is **Bot**. For the **Mag Error** graph, the default setting is **Ctr**.
- **Scale Coupling** - Allows you to toggle the scale coupling function between **On** and **Off**. The default setting is **On**. Upon pressing the **Restart** front-panel key or the **Restart** softkey under the **Meas Control** menu, the scale coupling function automatically determines the

scale per division and reference values based on the measurement results. When you set a value to either **Scale/Div** or **Ref Value** manually, **Scale Coupling** automatically changes to **Off**.

If the Phase Error window is active in the **I/Q Error (Quad View)** view, the **AMPLITUDE Y Scale** key accesses the menu to allow the following settings:

- **Scale/Div** - Allows you to set the vertical scale by changing the value per division. The range is 0.01 to 3600.0 degrees. The default setting is 5.00 degrees per division. However, since the **Scale Coupling** default is **On**, this value is automatically determined by the measurement result. When you set a value manually, **Scale Coupling** automatically changes to **Off**.
- **Ref Value** - Allows you to set the reference value ranging from -36000 to 36000 degrees. The default setting is 0.00 degrees. However, since the **Scale Coupling** default is **On**, this value is automatically determined by the measurement results. When you set a value manually, **Scale Coupling** automatically changes to **Off**.
- **Ref Position** - Allows you to set the reference position to either **Top**, **Ctr** (center) or **Bot** (bottom). The default setting is **Ctr**.
- **Scale Coupling** - Allows you to toggle the scale coupling function between **On** and **Off**. The default setting is **On**. Upon pressing the **Restart** front-panel key or the **Restart** softkey under the **Meas Control** menu, the scale coupling function automatically determines the scale per division and reference values based on the measurement results. When you set a value to either **Scale/Div** or **Ref Value** manually, **Scale Coupling** automatically changes to **Off**.

If I/Q Waveform window is active in the **I/Q Measured (Quad View)** view, the **AMPLITUDE Y Scale** key accesses the menu to allow the following settings:

- **Scale/Div** - Allows you to set the vertical scale by changing the voltage value per division. The range is 1.00 nV to 20.00 V per division. The default setting is 100.00 mV. However, since the **Scale Coupling** default is **On**, this value is automatically determined by the measurement result. When you set a value manually, **Scale Coupling** automatically changes to **Off**.
- **Ref Value** - Allows you to set the reference value ranging from -250.00 to 250.00 V. The default setting is 0.00 V. However, since the **Scale Coupling** default is **On**, this value is automatically determined by the measurement results. When you set a value manually, **Scale Coupling** automatically changes to **Off**.
- **Ref Position** - Allows you to set the reference position to either **Top**, **Ctr** (center) or **Bot** (bottom). The default setting is **Ctr**.
- **Scale Coupling** - Allows you to toggle the scale coupling function

between **On** and **Off**. The default setting is **On**. Upon pressing the **Restart** front-panel key or the **Restart** softkey under the **Meas Control** menu, the scale coupling function automatically determines the scale per division and reference values based on the measurement results. When you set a value to either **Scale/Div** or **Ref Value** manually, **Scale Coupling** automatically changes to **Off**.

If **Chip Power** window is active in the **I/Q Measured (Quad View)** view, the **AMPLITUDE Y Scale** key accesses the menu to allow the following settings:

- **Scale/Div** - Allows you to set the vertical scale by changing the power value per division. The range is 0.10 to 20.00 dB per division. The default setting is 10.00 dB. However, since the **Scale Coupling** default is **On**, this value is automatically determined by the measurement result. When you set a value manually, **Scale Coupling** automatically changes to **Off**.
- **Ref Value** - Allows you to set the reference value ranging from -250.00 to 250.00 dB. The default setting is 0.00 dB. However, since the **Scale Coupling** default is **On**, this value is automatically determined by the measurement results. When you set a value manually, **Scale Coupling** automatically changes to **Off**.
- **Ref Position** - Allows you to set the reference position to either **Top**, **Ctr** (center) or **Bot** (bottom). The default setting is **Ctr**.
- **Scale Coupling** - Allows you to toggle the scale coupling function between **On** and **Off**. The default setting is **On**. Upon pressing the **Restart** front-panel key or the **Restart** softkey under the **Meas Control** menu, the scale coupling function automatically determines the scale per division and reference values based on the measurement results. When you set a value to either **Scale/Div** or **Ref Value** manually, **Scale Coupling** automatically changes to **Off**.

Using the Markers

The **Marker** front-panel key accesses the menu to configure the markers depending on the display selected.

- **Select** - Allows you to activate up to four markers with the corresponding numbers, respectively. The selected number is underlined and its function is defined by pressing the **Function** key. The default setting is 1.
- **Normal** - Allows you to activate the selected marker to read the magnitude or phase error and the number of chips of the marker position on the selected trace, for example. Marker position is controlled by the RPG knob.
- **Delta** - Allows you to read the differences in the magnitude or phase errors and the number of chips between the selected marker and the

next.

- **Function** - Allows you to set the selected marker function to **Band Power**, **Noise**, or **Off**. The default setting is **Off**. The **Band Power** and **Noise** functions are not available for this measurement.
- **Trace** - Allows you to place the selected marker on the **EVM**, **Phase Error**, or **Mag Error** trace. The default setting is **EVM**.
- **Off** - Allows you to turn off the selected marker.
- **Shape** - Allows you to access the menu to set the selected marker shape to **Diamond**, **Line**, **Square**, or **Cross**. The default setting is **Diamond**.
- **Marker All Off** - Allows you to turn off all of the markers.

Troubleshooting Hints

A poor phase error often indicates a problem with the I/Q baseband generator, filters, and/or modulator in the transmitter circuitry of the UUT. The output amplifier in the transmitter can also create distortion that causes unacceptably high phase error. In a real system, a poor phase error will reduce the ability of a receiver to correctly demodulate the received signal, especially in marginal signal conditions.

Making the Reverse Link Modulation Accuracy (Composite Rho) Measurement

This section describes making MS tests, also known as reverse link tests. If you are going to make BTS tests or forward link tests, see “[Making the Forward Link Modulation Accuracy \(Composite Rho\) Measurement](#)” on page 197.

Purpose

Rho is one of the key modulation quality metrics, along with EVM and code domain power. Rho is the ratio of the correlated power in a single coded channel to the total signal power. This is a simplified case of code domain power since this measurement is made on a single coded channel. This measurement takes into account all possible error mechanisms in the entire transmission chain including baseband filtering, I/Q modulation anomalies, filter amplitude and phase non-linearities, and power amplifier distortion. This provides an overall indication of the performance level of the transmitter of the UUT.

Measurement Method

This procedure measures the performance of the transmitter’s modulation circuitry.

In a digitally modulated signal, it is possible to predict what the ideal magnitude and phase of the carrier should be at any time, based on the transmitted data sequence. The transmitter’s modulated signal is compared to an ideal signal vector. The difference between these two vectors is sampled and processed using DSP. Rho values are in the range of 0.000 to 1.000. A value of 1.000 indicates perfect correlation to the reference (high modulation quality).

Depending on the test equipment for MS, it is recommended that you use the trigger output signal from the instrument for synchronization.

If the error code 604 “Can not correlate to input signal” is shown, it means that your measurement has failed to find any active channels due to the lack of correlation with the input signal. The input signal level, for example, may need to be adjusted to obtain correlation.

With the Result Metrics view, the following data is provided:

Result Items	Example data shown	
Rho	0.99801	
EVM	4.48%rms	11.47%pk
Pk CDE	-48.71 dB at W128(100):I	
Magnitude Error	3.24%rms	
Phase Error	10.31°rms	
Freq Error	-49.12 Hz	
I/Q Origin Offset	-53.73 dB	
Pilot Offset	-2826.83 μs	
Active Channels	9	
Max Inactive Ch	-49.58 dBc at W16(12):Q	
Active CH	Code Domain Pwr	Pwr Ref to Pilot
Pilot W16(0):I	-10.02 dBc	Reference
RRI W16(0):I	-10.02 dBc	0.00 dB
ACK W8(4):I	-7.02 dBc	-3.02 dB
DRC W16(8):Q	-7.06 dBc	-2.96 dB
Data W4(2):Q	-6.26 dBc	-3.26 dB

Making the Measurement

NOTE

The factory default settings provide a cdma2000 compliant measurement. For special requirements, you may need to change some of the settings. Press **Meas Setup, More, Restore Meas Defaults** at any time to return all parameters for the current measurement to their default settings.

Select the desired center frequency as described in [“Changing the Frequency Channel” on page 77](#).

For PSA with Option 1DS Internal Preamplifier, see [“Configuring the Input Condition” on page 72](#) for details of **Int Preamp** and **Attenuator** operation.

Press **MEASURE, Mod Accuracy (Composite Rho)** to immediately make a modulation accuracy measurement. This section describes making MS tests, also known as reverse link tests. If you are going to make BTS tests or forward link tests, see [“Making the Forward Link Modulation Accuracy \(Composite Rho\) Measurement” on page 197](#).

To change any of the measurement parameters from the factory default values, refer to [“Changing the Measurement Setup” on page 216](#).

Results

The following figure shows an example result of I/Q Measured Polar Vector for the modulation accuracy measurements in the graph

window. The measured values for Rho, rms and peak EVM, peak code domain error with the code number, rms magnitude error, rms phase error, and other parameters are shown in the text window.

Figure 4-22 Modulation Accuracy Measurement - Polar Vector View

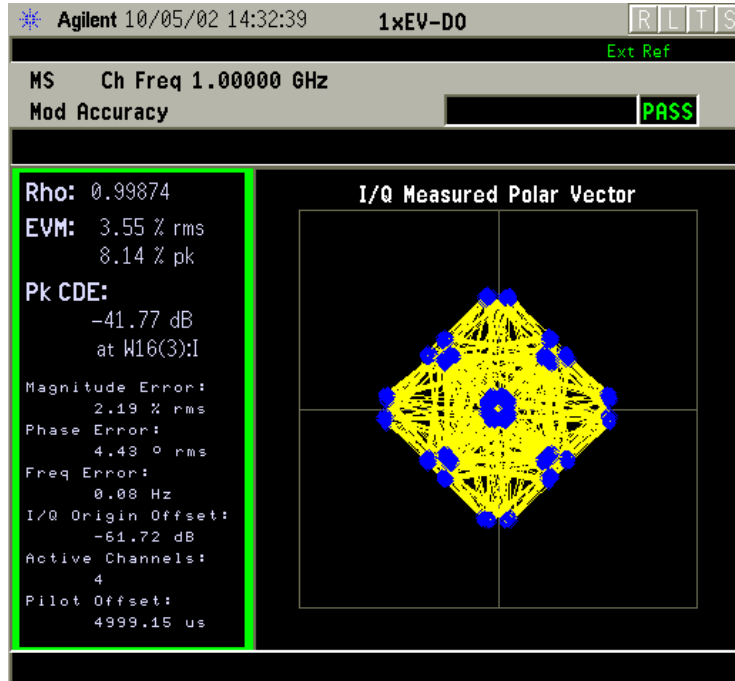

*Meas Setup: Factory default settings

*Input signal: 0.00 dBm, 1xEV-DO

Changing the Measurement Setup

This table shows the factory default settings for modulation accuracy (composite rho) measurements.

Table 4-12 Modulation Accuracy (Composite Rho) Measurement Defaults

Measurement Parameter	Factory Default Condition
View/Trace	I/Q Measured Polar Graph
Display:	
I/Q Polar Vec/Constln	Vec & Constln
Chip Offset	0 chips
Chip Interval	2048 chips
+45 deg Rot	Off
Full Vector (Background)	Off
Meas Setup:	

Table 4-12 Modulation Accuracy (Composite Rho) Measurement Defaults

Measurement Parameter	Factory Default Condition
Avg Number	10; On
Avg Mode	Repeat
Active Code Chan	Auto
Predefined Active Chan	
Pilot Chan (W16(0): I)	On
DRC Chan (W16(8): Q)	On
Ack Chan (W8(4): I)	On
Data Chan (W4(2): Q)	On
Limits:	
RMS EVM (Composite)	50.0 pcnt (%)
Peak EVM (Composite)	100.0 pcnt
Rho (Composite)	0.94400
Peak CDE	0.00 dB
Freq Error	300.0 Hz
Pilot Offset	1.000 μ s
Inactive CDP	-23.00 dBc
RRI/Plt Pwr Tolerance	0.25 dB
Active CDP Tolerance	0.25 dB
DRC Chan Gain	3.00 dB
ACK Chan Gain	3.00 dB
Data Chan Gain	3.75 dB
Trig Source	Free Run (Immediate)
I Long Code Mask	0
Q Long Code Mask	0
Spectrum	Normal
Advanced	
EVM Result I/Q Offset	Std
Chip Rate	1.228800 MHz
Multi Channel Estimator	Off
ADC Range: Manual	-6 dB (for E4406A), None (for PSA)

Making Measurements

Table 4-12

Modulation Accuracy (Composite Rho) Measurement Defaults

Measurement Parameter	Factory Default Condition
Active Set Th	---- dB; Auto

Make sure the **Mod Accuracy (Composite Rho)** measurement is selected under the **MEASURE** menu. Press the **Meas Setup** key to access a menu which allows you to modify the average number, average mode, and trigger source as described in “[Measurement Setup](#)” on page 127. The chip rate is fixed at 1.2288 MHz for SR1 in this measurement.

In addition, the following modulation accuracy measurement parameters can be modified.

- **Active Code Chan** - Allows you to access the menu of the following active channel identification functions.
 - **Auto** - Sets to automatically detect the active code channel(s). If the input power level is not stable, this detection method may not be effective.
 - **Combination** - Sets to use the active channels combined with the predefined active channel and those detected by the auto active channel detection function.
 - **Predefined** - Allows you to use the active code channels defined by the **Predefined Active Chan** key.
- **Predefined Active Chan** - Allows you to access the menu of the following channels for enabling each channel active or inactive. This key is disabled when **Active Code Chan** is set to **Auto**.
 - **Pilot Chan (W16(0):I)** - Allows you to toggle the pilot channel activation between **On** (active) and **Off** (inactive).
 - **DRC Chan (W16(8):Q)** - Allows you to toggle the DRC (data rate control) channel activation between **On** (active) and **Off** (inactive).
 - **Ack Chan (W8(4):I)** - Allows you to toggle the acknowledge channel activation between **On** (active) and **Off** (inactive).
 - **Data Chan (W4(2):Q)** - Allows you to toggle the data channel activation between **On** (active) and **Off** (inactive).
- **Limits** - Allows you to access the menu to set the following limits:
 - **RMS EVM (Composite)** - Allows you to set the limit for composite RMS EVM measurement result. The range is 0.00 to 50.00%.
 - **Peak EVM (Composite)** - Allows you to set the limit for composite peak EVM measurement result. The range is 0.00 to 100.00%.
 - **Rho (Composite)** - Allows you to set the limit for composite rho measurement result. The range is 0.00000 to 1.00000.

- **Peak CDE** - Allows you to set the limit for peak code domain error measurement result. The range is -100.0 to 0.0 dBm.
- **Freq Error** - Allows you to set the limit for frequency error measurement result. The range is 0.00 Hz to 10.00 kHz.
- **Pilot Offset** - Allows you to set the limit for pilot offset time from the trigger timing. The range is 0.0 to 100.0 ms.
- **Inactive CDP** - Allows you to set the limit for inactive channel code domain power measurement result. The range is -100.0 to 0.00 dBm.
- **RRI/Pit Pwr Tolerance** - Allows you to set the tolerance for RRI (reverse rate indicator) and pilot power ratio measurement result. The range is 0.00 to 3.00 dB.
- **Active CDP Tolerance** - Allows you to set the tolerance for each active code domain power level with its channel gain defined by **DRC Chan Gain**, **ACK Chan Gain**, or **Data Chan Gain**, respectively. The range is 0.00 to 3.00 dB.
- **DRC Chan Gain** - Allows you to set the power gain level of the DRC (data rate control) channel relative to the pilot channel power level. The range is -10.00 to 10.00 dB.
- **ACK Chan Gain** - Allows you to set the power gain level of the ACK (acknowledge) channel relative to the pilot channel power level. The range is -10.00 to 10.00 dB.
- **Data Chan Gain** - Allows you to set the power gain level of the data channel relative to the pilot channel power level. The range is -10.00 to 10.00 dB.
- **I Long Code Mask** - Allows you to set the long code mask value for the I signal. The value ranges from 0×0 to 0×3 FFFFFFFFFFFF (42 bits). This value is used in the long code generation process.
- **Q Long Code Mask** - Allows you to set the long code mask value for the Q signal. The value ranges from 0×0 to 0×3 FFFFFFFFFFFF (42 bits). This value is used in the long code generation process.
- **Spectrum** - Allows you to toggle the spectrum function between **Normal** and **Invert**. When set to **Invert**, it conjugates the spectrum, which effectively inverts the quadrature component in demodulation. The correct setting (**Normal** or **Invert**) depends on whether the signal being input to the instrument has a high or low side mix.
- **Advanced** - Allows you to access the menu to change the following parameters:
 - **EVM Result I/Q Offset** - Allows you to toggle the I/Q origin offset function between **Std** (standard) and **Exclude**. If set to **Std**, the measurement results for the error vector magnitude, rho, and

code domain error take into account the I/Q origin offset. If set to **Exclude**, the measurement results for EVM, Rho, and CDE do not take into account the I/Q origin offset, and the message “EVM excludes I/Q Offset” is displayed in the lower right graph display area. The default setting is **Std**.

- **Chip Rate** - Allows you to change the chip rate ranging from 1.10592 to 1.35168 MHz.
- **Multi Channel Estimator** - Allows you to toggle the multi channel estimator function between **On** and **Off**. When set to **On**, the measurement accuracy will be improved, but measurement speed will be reduced.
- **ADC Range** - Allows you to access the following selection menu to define one of the ADC ranging functions:
 - **Auto** - Select this to automatically set the ADC range. For most FFT measurements, the auto feature should not be selected. An exception is when measuring a “bursty” signal, in which case **Auto** can maximize the time domain dynamic range, if FFT results are less important to you than time domain results.
 - **Auto Peak** - Select this to set the ADC range automatically to the peak signal level. **Auto Peak** is a compromise that works well for both CW and burst signals.
 - **Auto Peak Lock** - Select this to hold the ADC range automatically at the peak signal level. **Auto Peak Lock** is more stable than **Auto Peak** for CW signals, but should not be used for “bursty” signals.
 - **Manual** - Allows you to access the selection menu of values, -6 to +24 dB for E4406A or None to +18 dB for PSA, to set the ADC range level. Also note that manual ranging is best for CW signals.
- **Active Set Th** - Allows you to toggle the active channel identification function between **Auto** and **Man** (manual). If set to **Auto**, the active channels are determined automatically by the internal algorithm. If set to **Man**, the active channel identification for each code channel is determined by a user definable threshold ranging from -100.00 to 0.00 dB.

Changing the View

The **View/Trace** key will allow you to select the desired measurement view from the following selections:

- **I/Q Measured Polar Graph** - Provides a combination view of an I/Q measured polar vector graph and the summary data as shown in [Figure 4-22 on page 216](#).

- **Result Metrics** - Provides a text view of the measured result data for rho, EVM, peak code domain error, magnitude error, phase error, and so forth as shown in [Figure 4-23](#).

Figure 4-23

Modulation Accuracy Measurement - Result Metrics View

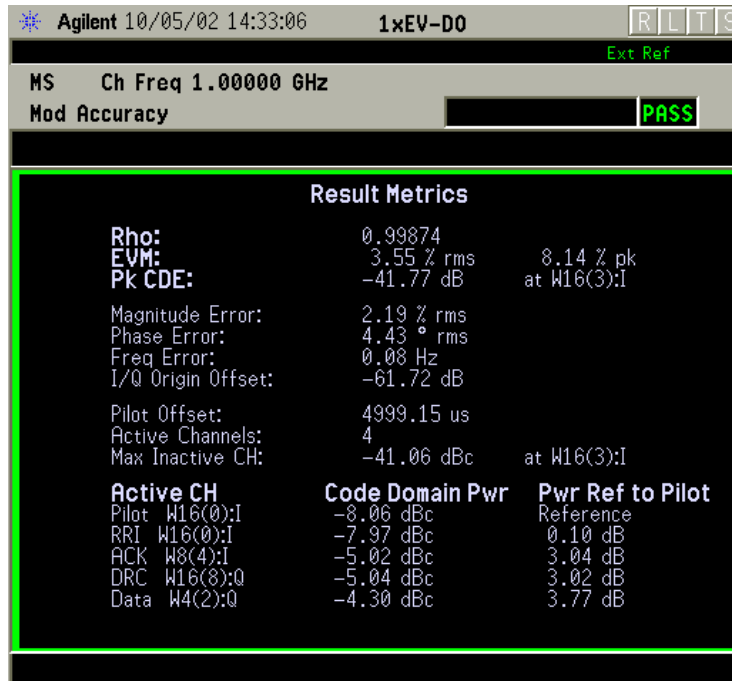

Making Measurements

*Meas Setup: View/Trace = Result Metrics,
Others = Factory default settings

*Input signal: 0.00 dBm, 1xEV-DO

- **I/Q Error (Quad-View)** - Four display windows show Mag Error, Phase Error, and EVM graphs, and the summary data for the composite rho, rms and peak EVM, peak code domain error with the code number, rms magnitude error, rms phase error, frequency error, and other parameters as shown in [Figure 4-24](#).

Figure 4-24 Modulation Accuracy Measurement - I/Q Error Quad View

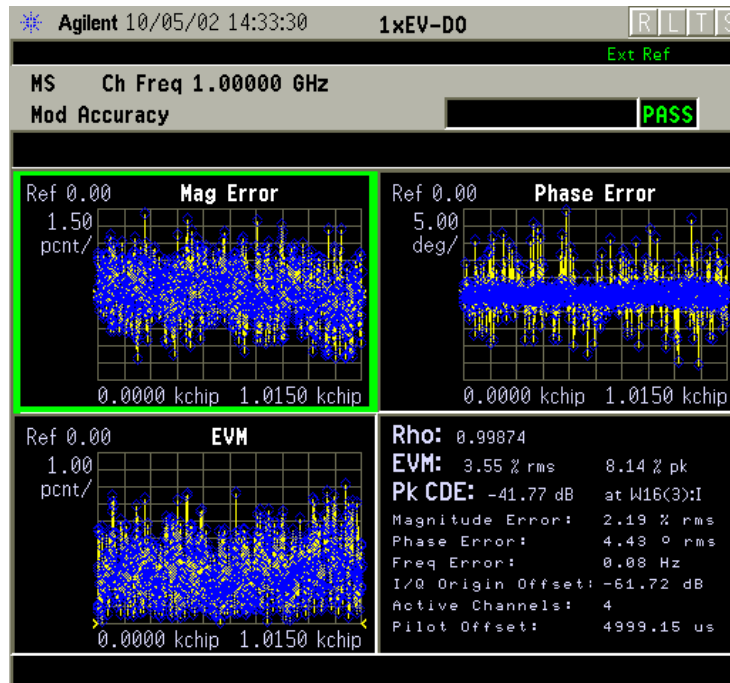

*Meas Setup: View/Trace = I/Q Error (Quad View),
Others = Factory Default Settings

*Input signal: 0.00 dBm, 1xEV-DO

Any one of these windows can be selected by the **Next Window** key and made full size using the **Zoom** key.

Changing the Display

The **Display** key accesses the menu which makes the following selections available to change the displays for I/Q Measured Polar Vector, Mag Error, Phase Error, EVM graphs:

- **I/Q Polar Vec/Constln** - Allows you to access the menu of the following parameters:
 - **Vect & Constln** - Sets to display the I/Q polar graph with the vector trajectory traces and constellation spots.
 - **Vec** - Sets to display the I/Q polar graph with the vector trajectory traces.
 - **Constln** - Sets to display the I/Q polar graph with the constellation spots.
- **Chip Offset** - Allows you to specify the number of chips offset from the first chip in the captured slot to the first chip displayed for the I/Q waveforms. The range is 0 to 2048 chips. The sum of **Chip Offset** and **Chip Interval** should be equal to or less than 2048.

- **Chip Interval** - Allows you to specify the number of chips to be displayed from the chip number set by **Chip Offset** for I/Q waveforms. The range is 0 to 2048 chips. The sum of **Chip Offset** and **Chip Interval** should be equal to or less than 2048.
- **+45 deg Rot** - Allows you to toggle the display rotation function between **On** and **Off**. If this is set to **On**, the I/Q polar vector or constellation graph is rotated by +45 degrees to see a rectangular display. The default setting is **Off**. This key does not affect the **I/Q Error (Quad View)** display.
- **Full Vector (Background)** - Allows you to toggle the full vector display function between **On** and **Off**. If set to **On**, the full vector traces in gray color are displayed in the background of the polar vector solid traces in yellow. The default setting is **Off**. If **View/Trace** is set to **I/Q Measured Polar Constln**, this key is disabled. This key does not affect the **I/Q Error (Quad View)** display.

If either EVM, Phase Error, or Mag Error window is active in the **I/Q Error (Quad-View)** view, the **SPAN X Scale** key accesses the menu to allow the following settings:

- **Scale/Div** - Allows you to set the horizontal scale by changing a chip value per division. The range is 1.0 to 200.0 chips per division. The default setting is 153.5 chips per division. However, since the **Scale Coupling** default **On**, this value is automatically determined by the measurement result. When you set a value manually, **Scale Coupling** automatically changes to **Off**.
- **Ref Value** - Allows you to set the chip reference value ranging from 0.0 to 2000.0 chips. The default setting is 0.0 chip. However, since the **Scale Coupling** default is **On**, this value is automatically determined by the measurement results. When you set a value manually, **Scale Coupling** automatically changes to **Off**.
- **Ref Position** - Allows you to set the reference position to either **Left**, **Ctr** (center) or **Right**. The default setting is **Left**.
- **Scale Coupling** - Allows you to toggle the scale coupling function between **On** and **Off**. The default setting is **On**. Upon pressing the **Restart** front-panel key or the **Restart** softkey under the **Meas Control** menu, scale coupling automatically determines the scale per division and reference values based on the measurement results. When you set a value to either **Scale/Div** or **Ref Value** manually, **Scale Coupling** automatically changes to **Off**.

If either EVM or Mag Error window is active in the **I/Q Error (Quad-View)** view, the **AMPLITUDE Y Scale** key accesses the menu to allow the following settings:

- **Scale/Div** - Allows you to set the vertical scale by changing the value per division. The range is 0.100 to 50.0% per division. The default setting is 5.00%. However, since the **Scale Coupling** default is **On**, this

value is automatically determined by the measurement result. When you set a value manually, **Scale Coupling** automatically changes to **Off**.

- **Ref Value** - Allows you to set the reference value ranging from 0.00 to 500.0%. The default setting is 0.00%. However, since the **Scale Coupling** default is **On**, this value is automatically determined by the measurement results. When you set a value manually, **Scale Coupling** automatically changes to **Off**.
- **Ref Position** - Allows you to set the reference position to either **Top**, **Ctr** (center) or **Bot** (bottom). For the EVM graph, the default setting is **Bot**. For the Mag Error graph, the default setting is **Ctr**.
- **Scale Coupling** - Allows you to toggle the scale coupling function between **On** and **Off**. The default setting is **On**. Upon pressing the **Restart** front-panel key or the **Restart** softkey under the **Meas Control** menu, scale coupling automatically determines the scale per division and reference values based on the measurement results. When you set a value to either **Scale/Div** or **Ref Value** manually, **Scale Coupling** automatically changes to **Off**.

If the **Phase Error** window is active in the **I/Q Error (Quad-View)** view, the **AMPLITUDE Y Scale** key accesses the menu to allow the following settings:

- **Scale/Div** - Allows you to set the vertical scale by changing the value per division. The range is 0.01 to 3600.0 degrees. The default setting is 5.00 degrees per division. However, since the **Scale Coupling** default is **On**, this value is automatically determined by the measurement result. When you set a value manually, **Scale Coupling** automatically changes to **Off**.
- **Ref Value** - Allows you to set the reference value ranging from -36000 to 36000 degrees. The default setting is 0.00 degrees. However, since the **Scale Coupling** default is **On**, this value is automatically determined by the measurement results. When you set a value manually, **Scale Coupling** automatically changes to **Off**.
- **Ref Position** - Allows you to set the reference position to either **Top**, **Ctr** (center) or **Bot** (bottom). The default setting is **Ctr**.
- **Scale Coupling** - Allows you to toggle the scale coupling function between **On** and **Off**. The default setting is **On**. Upon pressing the **Restart** front-panel key or the **Restart** softkey under the **Meas Control** menu, scale coupling automatically determines the scale per division and reference values based on the measurement results. When you set a value to either **Scale/Div** or **Ref Value** manually, **Scale Coupling** automatically changes to **Off**.

Using the Markers

The **Marker** front-panel key accesses the menu to configure the markers depending on the display selected.

- **Select** - Allows you to activate up to four markers with the corresponding numbers, respectively. The selected number is underlined and its function is defined by pressing the **Function** key. The default setting is 1.
- **Normal** - Allows you to activate the selected marker to read the magnitude or phase error and the number of chips of the marker position on the selected trace, for example. Marker position is controlled by the RPG knob.
- **Delta** - Allows you to read the differences in the magnitude or phase errors and the number of chips between the selected marker and the next.
- **Function** - Allows you to set the selected marker function to **Band Power**, **Noise**, or **Off**. The default setting is **Off**. The **Band Power** and **Noise** functions are not available for this measurement.
- **Trace** - Allows you to place the selected marker on the **EVM**, **Phase Error**, or **Mag Error** trace. The default setting is **EVM**.
- **Off** - Allows you to turn off the selected marker.
- **Shape** - Allows you to access the menu to set the selected marker shape to **Diamond**, **Line**, **Square**, or **Cross**. The default setting is **Diamond**.
- **Marker All Off** - Allows you to turn off all of the markers.

Troubleshooting Hints

A poor phase error often indicates a problem with the I/Q baseband generator, filters, and/or modulator in the transmitter circuitry of the UUT. The output amplifier in the transmitter can also create distortion that causes unacceptably high phase error. In a real system, a poor phase error will reduce the ability of a receiver to correctly demodulate the received signal, especially in marginal signal conditions.

Making the QPSK EVM Measurement

Purpose

Phase and frequency errors are measures of modulation quality for the 1xEV-DO system. This modulation quality is obtained through QPSK Error Vector Magnitude (EVM) measurements. Since the 1xEV-DO system uses Quadrature Phase Shift Keying (QPSK) modulation, the phase and frequency accuracies of the transmitter are critical to the communications system performance and ultimately affect range.

1xEV-DO receivers rely on the phase and frequency quality of the QPSK modulation signal in order to achieve the expected carrier to noise ratio. A transmitter with high phase and frequency errors will often still be able to support phone calls during a functional test. However, it will tend to cause difficulty for mobiles trying to maintain service at the edge of the cell with low signal levels or under difficult fading and Doppler conditions.

Measurement Method

The input signal needs to be a single coded signal, such as a pilot channel. The phase error of the unit under test is measured by computing the difference between the phase of the transmitted signal and the phase of a theoretically perfect signal.

The instrument samples the transmitter output in order to capture the actual phase trajectory. This is then demodulated and the ideal phase trajectory is mathematically derived using detected bits and channel filtering. Subtracting one from the other results in a phase error signal.

This measurement allows you to display these errors numerically and graphically on the instrument display. There are graphs for EVM, Phase Error and Mag Error in the graph windows. In the text window, there are both maximum and average data for Evm: in % rms, in % peak, RMS Mag Error: in %, Phase Error: in degrees, Freq Error: in Hz, and IQ Offset: in dB.

Making the Measurement

NOTE

The factory default settings provide a 3GPP2 compliant measurement. For special requirements, you may need to change some of the settings. Press **Meas Setup**, **More**, **Restore Meas Defaults** at any time to return all parameters for the current measurement to their default settings.

Select the desired center frequency as described in [“Changing the Frequency Channel”](#) on page 77.

For PSA with Option 1DS Internal Preamplifier, see “[Configuring the Input Condition](#)” on page 72 for details of **Int Preamp** and **Attenuator** operation.

Press **MEASURE, QPSK EVM** to immediately make a QPSK error vector magnitude (EVM) measurement. This measurement is applicable only for BTS (Fwd) tests.

To change any of the measurement parameters from the factory default values, refer to “[Changing the Measurement Setup](#)” on page 228.

Results

The following figure shows an example result of I/Q Measured Polar Vector for the QPSK EVM measurements in the graph window. The maximum and average measured data such as rms and peak EVM, magnitude error, phase error, frequency error, and so forth are shown in the text window.

Figure 4-25

QPSK EVM Measurement - I/Q Polar Vector View

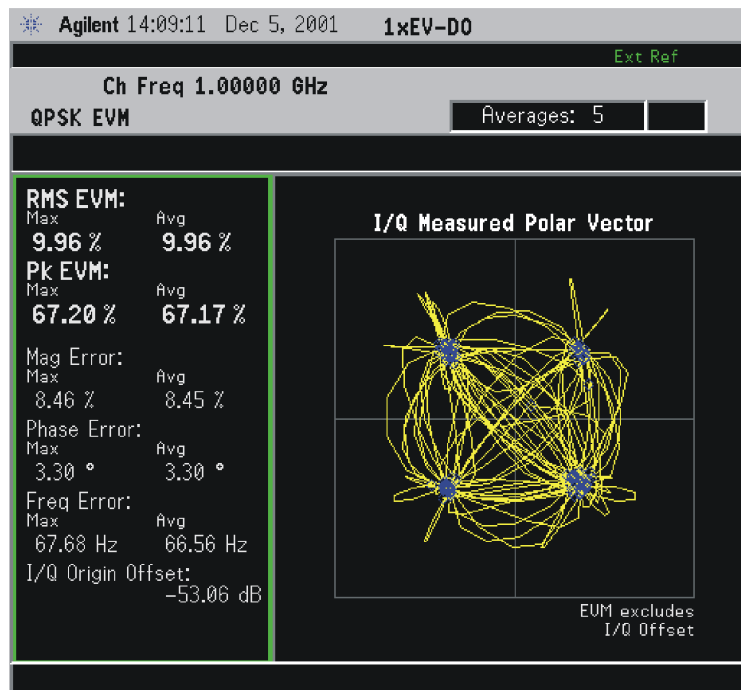

*Meas Setup: Factory default settings

*Input signal: -10.00 dBm, Pilot channel, 1xEV-DO

Changing the Measurement Setup

This table shows the factory default settings for QPSK EVM measurements.

Table 4-13 QPSK EVM Measurement Defaults

Measurement Parameter	Factory Default Condition
View/Trace	I/Q Measured Polar Vector
Display:	
I/Q Points	1280
Chip Dots	On
Meas Setup:	
Avg Number	10; On
Avg Mode	Repeat
Meas Offset & Interval	
Meas Offset:	464.0 chips (377.6 μ s)
Meas Interval:	96.0 chips (78.1 μ s)
Pre-Defined Ofs/Intvl:	Pilot #1
Limits	RMS EVM 50.0 pcent
Trig Source	Ext Front
Advanced	
Chip Rate:	1.22880 MHz
ADC Range:	
Manual	-6 dB (for E4406A), None (for PSA)

Make sure the **QPSK EVM** measurement is selected under the **MEASURE** menu. Press the **Meas Setup** key to access a menu which allows you to modify the average number, average mode, and trigger source for this measurement as described in “[Measurement Setup](#)” on page 127.

In addition, the following parameters can be modified according to your measurement requirements:

- **Meas Offset & Interval** - Allows you to access the menus to set the offset and time interval over which the measurement is made.
 - **Meas Offset** - Allows you to set a value for the measurement offset in either μ s or chips. When you enter a numeric value, the unit selection menu is shown. The range is from 17.9 to 1667.0 μ s, or 22 to 2048 chips.
 - **Meas Interval** - Allows you to set a value for the measurement interval in either μ s or chips. When you enter a numeric value, the unit selection menu is shown. The range is from 26.0 to

1667.0 μ s, or 32 to 2048 chips.

- **Pre-Defined Ofs/Intvl** - Allows you to select one of the following predefined channels or slots. The default selection is **Pilot #1** that is shown on this key. When you enter a value in either **Meas Offset** or **Meas Interval**, “-----” is shown. The channel and slot definitions are summarized in the illustration and table below.
 - Pilot** - Allows you to set either **Pilot #1** or **#2** of pilot channel as the preset measurement offset and interval.
 - MAC** - Allows you to set either **MAC #1**, **#2**, **#3**, or **#4** of medium access control (MAC) channel as the preset measurement offset and interval.
 - Idle Slot** - Allows you to set either **Idle Slot #1** or **#2** of idle slot as the preset measurement offset and interval.

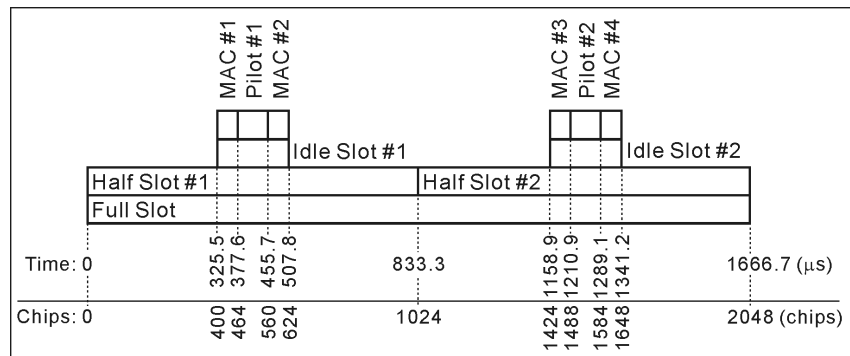

Selection	Meas Offset		Meas Interval	
	Time (μ s)	Chips	Time (μ s)	Chips
Pilot #1	377.6	464	78.1	96
Pilot #2	1210.9	1488	78.1	96
MAC #1	325.5	400	52.1	64
MAC #2	455.7	560	52.1	64
MAC #3	1158.9	1424	52.1	64
MAC #4	1289.1	1584	52.1	64
Idle Slot #1	325.5	400	182.3	224
Idle Slot #2	1158.9	1424	182.3	224

- **Advanced** - Allows you to access the menu to change the following parameters:
 - **Chip Rate** - Allows you to change the chip rate. The range is 1.10592 to 1.35168 MHz for SR1.
 - **ADC Range** - Allows you to access the following selection menu to

define one of the ADC ranging functions:

- ❑ **Auto** - Select this to set the ADC range automatically. For most FFT measurements, the auto feature should not be selected. An exception is when measuring a “bursty” signal, in which case **Auto** can maximize the time domain dynamic range, if FFT results are less important to you than time domain results.
- ❑ **Auto Peak** - Select this to set the ADC range automatically to the peak signal level. **Auto Peak** is a compromise that works well for both CW and burst signals.
- ❑ **Auto Peak Lock** - Select this to hold the ADC range automatically at the peak signal level. **Auto Peak Lock** is more stable than **Auto Peak** for CW signals, but should not be used for “bursty” signals.
- ❑ **Manual** - Allows you to access the selection menu of values, –6 dB to +24 dB for E4406A or None to +18 dB for PSA, to set the ADC range level. Also note that manual ranging is best for CW signals.

Changing the View

The **View/Trace** key will allow you to select the desired view of the measurement from the following:

- **I/Q Measured Polar Vector** - Provides a combination view of an I/Q measured polar vector graph and the maximum and average summary data as shown in [Figure 4-25 on page 227](#).
- **I/Q Measured Polar ConstIn** - Provides a combination view of an I/Q measured polar constellation graph and the maximum and average summary data for the rms EVM, peak EVM, magnitude error, phase error, frequency error, and so forth in the text window as shown in [Figure 4-26 on page 231](#).

Figure 4-26 QPSK EVM Measurement - I/Q Polar Constellation View

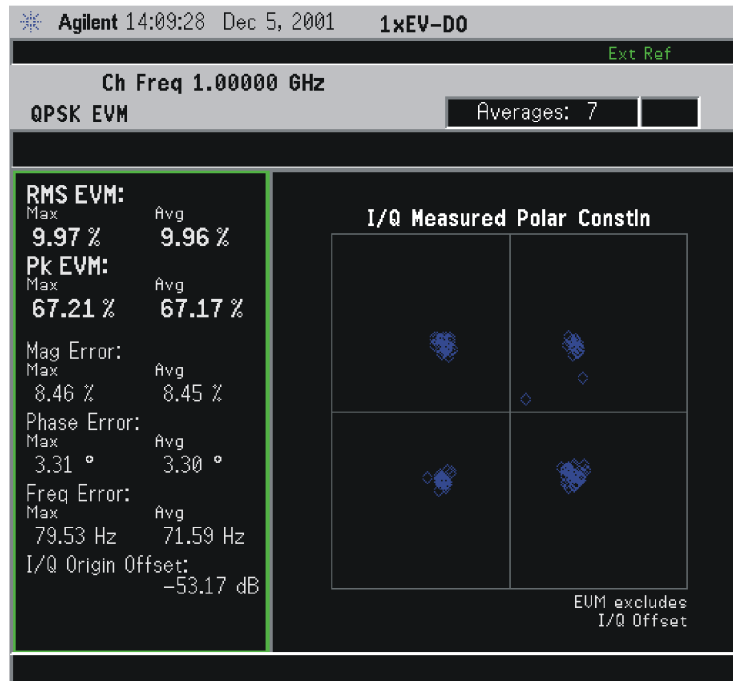

*Meas Setup: View/Trace = I/Q Measured Polar Constln,
 Others = Factory default settings

*Input signal: -10.00 dBm, Pilot channel, 1xEV-DO

- **I/Q Error (Quad View)** - Four display windows show Mag Error, Phase Error and EVM graphs, and the maximum and average summary data for the rms EVM, peak EVM, magnitude error, phase error, frequency error, and so forth in the text window as shown in [Figure 4-27](#).

Figure 4-27 QPSK EVM Measurement - I/Q Error Quad View

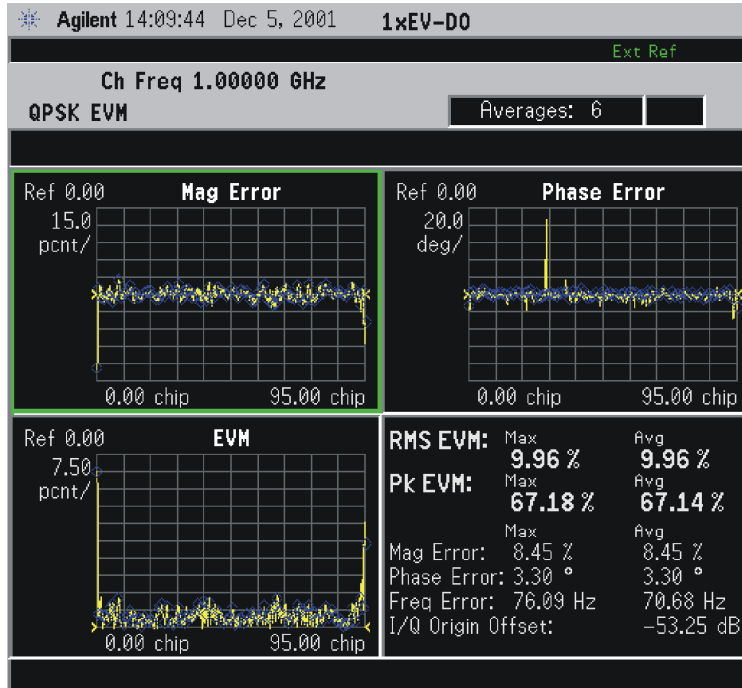

*Meas Setup: View/Trace = I/Q Error (Quad View),
 Others = Factory default settings

*Input signal: -10.00 dBm, Pilot channel, 1xEV-DO

Any of these windows can be selected using the **Next Window** key and made full size using the **Zoom** key.

Changing the Display

The **Display** key accesses the menu to allow the following selections for changing the graph displays of I/Q Measured Polar Vector, I/Q Measured Constln, and I/Q Error (Quad View):

- **I/Q Points** - Allows you to specify the number of displayed points for the I/Q waveforms. The range is 1 to 2560 points with the points per chip fixed at 5, depending on the **Meas Interval** setting. This key has no affect on the **I/Q Error (Quad View)** display.
- **Chip Dots** - Allows you to toggle the chip dot display between **On** and **Off**. If set to **On**, the chip dots in yellow are overlaid on the I/Q polar graph. If **View/Trace** is set to **I/Q Measured Polar Constln**, this key is disabled.

If either EVM, Phase Error, or Mag Error window is active in the **I/Q Error (Quad View)** view, the **SPAN X Scale** key accesses the menu to allow the following settings:

- **Scale/Div** - Allows you to set the horizontal scale by changing a chip value per division. The range is 1.0 to 128.0 chips per division. The

default setting is 25.50 chips per division. However, since the **Scale Coupling** default is **On**, this value is automatically determined by the measurement result. When you set a value manually, **Scale Coupling** automatically changes to **Off**.

- **Ref Value** - Allows you to set the chip reference value ranging from 0.0 to 1280.0 chips. The default setting is 0.0 chips. However, since the **Scale Coupling** default is **On**, this value is automatically determined by the measurement results. When you set a value manually, **Scale Coupling** automatically changes to **Off**.
- **Ref Position** - Allows you to set the reference position to either **Left**, **Ctr** (center) or **Right**. The default setting is **Left**.
- **Scale Coupling** - Allows you to toggle the scale coupling function between **On** and **Off**. The default setting is **On**. Upon pressing the **Restart** front-panel key or the **Restart** softkey under the **Meas Control** menu, the scale coupling function automatically determines the scale per division and reference values based on the measurement results. When you set a value to either **Scale/Div** or **Ref Value** manually, **Scale Coupling** automatically changes to **Off**.

If either EVM or Mag Error window is active in the **I/Q Error (Quad View)** view, the **AMPLITUDE Y Scale** key accesses the menu to allow the following settings:

- **Scale/Div** - Allows you to set the vertical scale by changing the value per division. The range is 0.100 to 50.0% per division. The default setting is 5.00%. However, since the **Scale Coupling** default is **On**, this value is automatically determined by the measurement result. When you set a value manually, **Scale Coupling** automatically changes to **Off**.
- **Ref Value** - Allows you to set the reference value ranging from 0.00 to 500.0%. The default setting is 0.00%. However, since the **Scale Coupling** default is **On**, this value is automatically determined by the measurement results. When you set a value manually, **Scale Coupling** automatically changes to **Off**.
- **Ref Position** - Allows you to set the reference position to either **Top**, **Ctr** (center) or **Bot** (bottom). For the EVM graph, the default setting is **Bot**. For the Mag Error graph, the default setting is **Ctr**.
- **Scale Coupling** - Allows you to toggle the scale coupling function between **On** and **Off**. The default setting is **On**. Upon pressing the **Restart** front-panel key or the **Restart** softkey under the **Meas Control** menu, the scale coupling function automatically determines the scale per division and reference values based on the measurement results. When you set a value to either **Scale/Div** or **Ref Value** manually, **Scale Coupling** automatically changes to **Off**.

When the Phase Error window is active in the **I/Q Error (Quad View)** display, the **AMPLITUDE Y Scale** key accesses the menu to allow the

following settings:

- **Scale/Div** - Allows you to set the vertical scale by changing the value per division. The range is 0.01 to 3600 degrees. The default setting is 0.10 degrees per division. However, since the **Scale Coupling** default is **On**, this value is automatically determined by the measurement result. When you set a value manually, **Scale Coupling** automatically changes to **Off**.
- **Ref Value** - Allows you to set the reference value ranging from -36000 to 36000 degrees. The default setting is 0.00 degrees. However, since the **Scale Coupling** default is **On**, this value is automatically determined by the measurement results. When you set a value manually, **Scale Coupling** automatically changes to **Off**.
- **Ref Position** - Allows you to set the reference position to either **Top**, **Ctr** (center) or **Bot** (bottom). The default setting is **Ctr**.
- **Scale Coupling** - Allows you to toggle the scale coupling function between **On** and **Off**. The default setting is **On**. Upon pressing the **Restart** front-panel key or the **Restart** softkey under the **Meas Control** menu, the scale coupling function automatically determines the scale per division and reference values based on the measurement results. When you set a value to either **Scale/Div** or **Ref Value** manually, **Scale Coupling** automatically changes to **Off**.

Using the Markers

The **Marker** front-panel key accesses the menu to configure the markers depending on the display selected.

- **Select** - Allows you to activate up to four markers with the corresponding numbers, respectively. The selected number is underlined and its function is defined by pressing the **Function** key. The default setting is 1.
- **Normal** - Allows you to activate the selected marker to read the magnitude or phase error and the number of chips of the marker position on the selected trace, for example. Marker position is controlled by the RPG knob.
- **Delta** - Allows you to read the differences in the magnitude or phase errors and the number of chips between the selected marker and the next.
- **Function** - Allows you to set the selected marker function to **Band Power**, **Noise**, or **Off**. The default setting is **Off**. The **Band Power** and **Noise** functions are not available for this measurement.
- **Trace** - Allows you to place the selected marker on the **EVM**, **Phase Error**, or **Mag Error** trace. The default setting is **EVM**.
- **Off** - Allows you to turn off the selected marker.

- **Shape** - Allows you to access the menu to set the selected marker shape to **Diamond**, **Line**, **Square**, or **Cross**. The default setting is **Diamond**.
- **Marker All Off** - Allows you to turn off all of the markers.

Troubleshooting Hints

A poor phase error indicates a problem with the I/Q baseband generator, filters, and/or modulator in the transmitter circuitry of the UUT. The output amplifier in the transmitter can also create distortion that causes unacceptably high phase error. In a real system, a poor phase error will reduce the ability of a receiver to correctly demodulate the received signal, especially in marginal signal conditions.

Making the Power Stat CCDF Measurement

Purpose

Many of the digitally modulated signals now look noise-like in the time and frequency domain. This means that statistical measurements of the signals can be a useful characterization. Power Complementary Cumulative Distribution Function (CCDF) curves characterize the higher-level power statistics of a digitally-modulated signal. The curves can be useful in determining design parameters for digital communications systems.

The power statistics CCDF measurement can be affected by many factors. For example, modulation filtering, modulation format, combining the multiple signals at different frequencies, number of active codes and correlation between symbols on different codes with spread spectrum systems. These factors are all related to modulation and signal parameters. External factors such as signal compression and expansion by non-linear components, group delay distortion from filtering, and power control within the observation interval also affect the measurement.

Measurement Method

The power measured in power statistics CCDF curves is actually instantaneous envelope power defined by the equation:

$$P = (I^2 + Q^2)/Z_0$$

(where I and Q are the quadrature voltage components of the waveform and Z_0 is the characteristic impedance).

A CCDF curve is defined by how much time the waveform spends at or above a given power level. The percent of time the signal spends at or above the level defines the probability for that particular power level. To make a power statistics CCDF measurement, the instrument uses digital signal processing (DSP) to sample the input signal in the channel bandwidth.

The Gaussian distribution line as the band-limited gaussian noise CCDF reference line, the user-definable reference trace, and the currently measured trace can be displayed on a semi-log graph. If the currently measured trace is above the user reference trace, it means that the higher peak power levels against the average power are included in the input signal.

Making the Measurement

NOTE

The factory default settings provide a 1xEV-DO general purpose measurement. For special requirements, you may need to change some of the settings. Press **Meas Setup, More, Restore Meas Defaults** at any time to return all parameters for the current measurement to their default settings.

Select the desired center frequency as described in “[Changing the Frequency Channel](#)” on page 77.

Press **MEASURE, Power Stat CCDF** to immediately make a power statistics CCDF measurement.

To change any of the measurement parameters from the factory default values, refer to “[Changing the Measurement Setup](#)” on page 238.

Results

The following figure shows an example result of Power Stat CCDF measurements in the graph window. The average power and its probability are shown in the text window.

Figure 4-28

Power Statistics CCDF Measurement

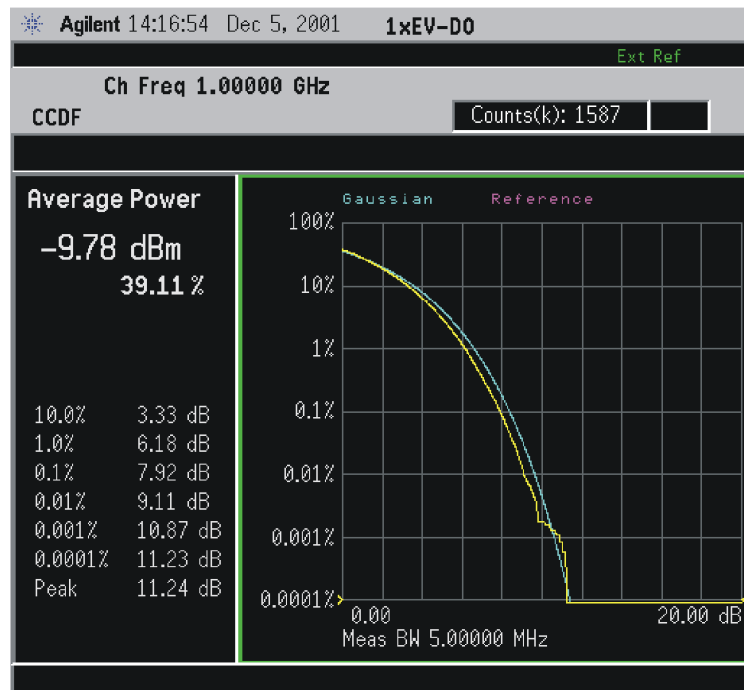

*Meas Setup: Factory default settings

*Input signal: -10.00 dBm, Pilot channel, 1xEV-DO

Changing the Measurement Setup

This table shows the factory default settings for power statistics CCDF measurements.

Table 4-14 Power Statistics CCDF Measurement Defaults

Measurement Parameter	Factory Default Condition
Meas Setup:	
Meas BW	5.00000 MHz
Counts	10.0000 Mpoints
Meas Interval	1.000 ms
Trig Source	Free Run (Immediate)
Meas Control:	
Measure	Single
Display:	
Ref Trace	Off
Gaussian Line	On

Make sure the **Power Stat CCDF** measurement is selected under the **MEASURE** menu. Press the **Meas Setup** key to access the menu which allows you to modify the trigger source for this measurement as described in [“Measurement Setup” on page 127](#).

In addition, the following parameters can be modified according to your measurement requirements:

- **Meas BW** - Allows you to set the measurement bandwidth according to the channel bandwidth. The range is 10.000 kHz to 6.70000 MHz with 0.1 kHz resolution.
- **Counts** - Allows you to set the accumulated number of sampling points for data acquisition. The range is 1.000 kpoints to 2.000 Gpoints with 1 or 10 kpoints resolution. While this key is activated, enter a value from the numeric keypad by terminating with one of the unit keys shown.
- **Meas Interval** - Allows you to specify the time interval over which the measurement is made. The range is 100.0 μ s to 10.00 ms with 1 μ s resolution.

Changing the View

The **View /Trace** key is not available for this measurement

Changing the Display

The **Display** key allows you to control the desired trace and line displays of the power statistics CCDF curves. The currently measured curve is always shown.

- **Store Ref Trace** - Allows you to copy the currently measured curve as the user-definable reference trace. The captured data will remain until the other mode is chosen. Pressing this key refreshes the reference trace.
- **Ref Trace** - Allows you to toggle the reference trace display function between **On** and **Off**.
- **Gaussian Line** - Allows you to toggle the Gaussian line display function between **On** and **Off**.

The **SPAN X Scale** key accesses the menu to set the desired horizontal scale.

- **Scale/Div** - Allows you to enter a numeric value to change the horizontal display sensitivity. The range is 0.10 to 20.00 dB with 0.01 dB resolution. The default setting is 2.00 dB.

Using the Markers

The **Marker** front-panel key accesses the menu to configure the markers.

- **Select 1 2 3 4** - Allows you to activate up to four markers with the corresponding numbers, respectively. The selected number is underlined and its function is defined by pressing the **Function** key. The default selection is 1.
- **Normal** - Allows you to activate the selected marker to read the power level and probability of the marker position on the selected curve. Marker position is controlled by the RPG knob.
- **Delta** - Allows you to read the differences in the power levels and probabilities between the selected marker and the next.
- **Function** - Allows you to set the selected marker function to **Band Power**, **Noise**, or **Off**. The default setting is **Off**. The **Band Power** and **Noise** functions are not available for this measurement.
- **Trace** - Allows you to place the selected marker on the **Measured**, **Gaussian**, or **Reference** curve. The default setting is **Measured**.
- **Off** - Allows you to turn off the selected marker.
- **Shape** - Allows you to access the menu to set the selected marker shape to **Diamond**, **Line**, **Square**, or **Cross**. The default setting is **Diamond**.
- **Marker All Off** - Allows you to turn off all of the markers.

Troubleshooting Hints

The power statistics CCDF measurement can help in determining the signal power specifications used as design criteria for systems, amplifiers, and other components. For example, it can help determine the optimum operating point to adjust code timing for appropriate peak/average power ratio throughout the wide channel bandwidth of the transmitter for a 1xEV-DO system.

As this measurement becomes more widely used the correlation between CCDF curve degradation and digital radio system measurement parameters such as BER, FER, code domain power, and ACPR will become more established. Further studies will eventually yield standards for radio design by specifying the maximum allowed CCDF curve degradation for specific systems.

As this measurement becomes more widely used the correlation between CCDF curve degradation and digital radio system measurement parameters such as BER, FER, code domain power, and ACPR will become more established. Further studies will eventually yield standards for radio design by specifying the maximum allowed CCDF curve degradation for specific systems.

Making the Spectrum (Frequency Domain) Measurement

Purpose

The spectrum measurement provides spectrum analysis capability for the instrument. The control of the measurement was designed to be familiar to those who are accustomed to using swept spectrum analyzers.

This measurement is FFT (Fast Fourier Transform) based. The FFT-specific parameters are located in the **Advanced** menu. Also available under basic mode spectrum measurements is an I/Q window, which shows the I and Q signal waveforms in parameters of voltage versus time. The advantage of having an I/Q view available while in the spectrum measurement is that it allows you to view complex components of the same signal without changing settings or measurements.

Measurement Method

The measurement uses digital signal processing to sample the input signal and convert it to the frequency domain. With the instrument tuned to a fixed center frequency, samples are digitized at a high rate, converted to I and Q components with DSP hardware, and then converted to the frequency domain with FFT software.

Making the Measurement

NOTE

The factory default parameters provide a good starting point. You will likely want to change some of the settings. Press **Meas Setup, More (1 of 2), Restore Meas Defaults** at any time to return all parameters for the current measurement to their default settings.

Press **MEASURE, Spectrum (Freq Domain)** to immediately make a spectrum measurement.

To change any of the measurement parameters from the factory default values, refer to the “Changing the Measurement Setup” section for this measurement.

Results

A display with both a Spectrum window and an I/Q Waveform window will appear when you activate a spectrum measurement. Use the **Next Window** key to select a window, and the **Zoom** key to enlarge a window.

Figure 4-29 Spectrum Measurement - Spectrum and I/Q Waveform View

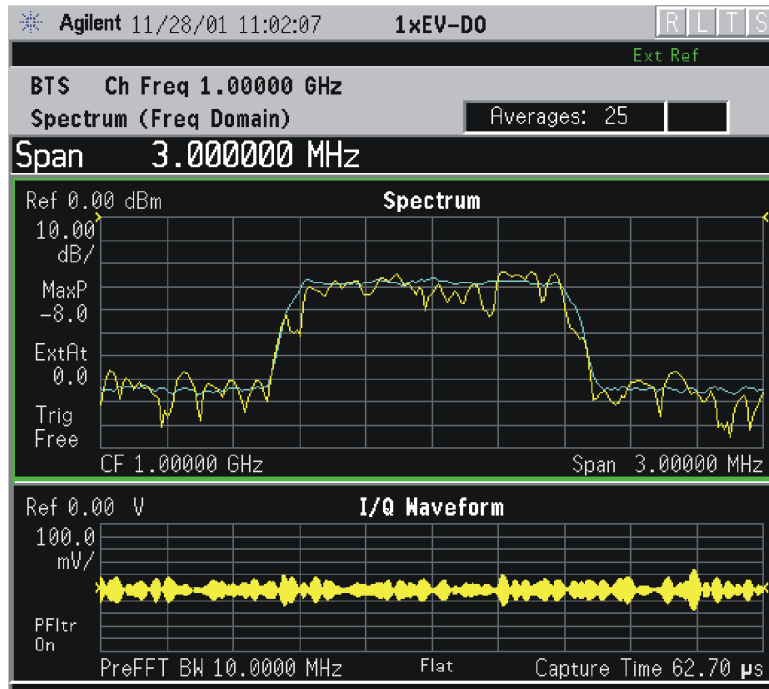

*Meas Setup: Span = 3.000 MHz, Capture Time = 62.70 μs,
 Others = Factory default settings

*Input signal: -10.00 dBm, Pilot channel, 1xEV-DO

Changing the Measurement Setup

The following table shows the factory default settings for spectrum (frequency domain) measurements.

Table 4-15 Spectrum (Frequency Domain) Measurement Defaults

Measurement Parameter	Factory Default Condition
View/Trace	Spectrum
Trace Display	All
Res BW	20.0000 kHz; Auto
Averaging:	
Avg Number	25; On
Avg Mode	Exp
Avg Type	Log-Pwr Avg (Video)
Trig Source	Free Run (Immediate)
Spectrum View:	
SPAN	1.00000 MHz
AMPLITUDE Y Scale - Scale/Div	10.00 dB

Table 4-15 **Spectrum (Frequency Domain) Measurement Defaults**

Measurement Parameter	Factory Default Condition
I/Q Waveform View: Capture Time AMPLITUDE Y Scale - Scale/Div	188.00 μ s 100.0 mV
Spectrum Linear View: SPAN AMPLITUDE Y Scale - Scale/Div	(for E4406A) 1.00000 MHz 100.0 mV
I and Q Waveform View: Capture Time AMPLITUDE Y Scale - Scale/Div	(for E4406A) 188.00 μ s 100.0 mV
I/Q Polar View: I/Q Scale/Div I or Q Origin	(for E4406A) 100.0 mV 0.00 V
Advanced	
Pre-ADC BPF	On
Pre-FFT Filter	Flat
Pre-FFT BW	1.55000 MHz; Auto
FFT Window	Flat Top (High Amptd Acc)
FFT Size:	
Length Control	Auto
Min Points/RBW	3.100000
Window Length	706
FFT Length	1024
ADC Range	Auto Peak
Data Packing	Auto
ADC Dither	Auto
Decimation	0; Auto
IF Flatness	On

NOTE Parameters under the **Advanced** key seldom need to be changed. Any changes from the default advanced values may result in invalid measurement data.

Make sure the **Spectrum (Freq Domain)** measurement is selected under the **MEASURE** menu. Press the **Meas Setup** key to access a menu which allows you to modify the averaging and trigger source for this measurement (as described in the “Measurement Setup” section). In addition, the following parameters can be modified:

- **Span** - Allows you to modify the frequency span. The range is 10.000 Hz to 10.000 MHz with 1 Hz resolution, depending on the **Res BW** setting. Changing the span causes the resolution bandwidth to change automatically, and will affect data acquisition time.
- **Res BW** - Allows you to set the resolution bandwidth for the FFT, and to toggle its mode between **Auto** and **Man** (manual). If set to **Auto**, the resolution bandwidth is set to **Span/50** (2% of the span). If set to **Man**, you can enter a value ranging from 100.0 mHz to 3.00000 MHz. A narrower bandwidth will result in a longer data acquisition time.
- **Advanced** - Allows you to access the menu to change the following parameters. The FFT advanced features should be used only if you are familiar with their operation. Changes from the default values may result in invalid data.
 - **Pre-ADC BPF** - Allows you to toggle the pre-ADC bandpass filter function between **On** and **Off**. The pre-ADC bandpass filter is useful for rejecting nearby signals, so that sensitivity within the span range can be improved by increasing the ADC range gain.
 - **Pre-FFT Filtr** - Allows you to toggle the pre-FFT filter between **Flat** (flat top) and **Gaussian**. The pre-FFT filter defaults to a flat top filter which has better amplitude accuracy. The Gaussian filter has better pulse response.
 - **Pre-FFT BW** - Allows you to toggle the pre-FFT bandwidth function between **Auto** and **Man** (manual). The pre-FFT bandwidth filter can be set between 1 Hz and 10 MHz. If set to **Auto**, this pre-FFT bandwidth is nominally 50% wider than the span. This bandwidth determines the ADC sampling rate.
 - **FFT Window** - Allows you to access the following selection menu. Unless you are familiar with FFT windows, use the flat top filter (the default filter).
 - Flat Top** - Selects this filter for best amplitude accuracy by reducing scalloping error.
 - Uniform** - Select this filter to have no window active by using the uniform setting.
 - Hanning** - Press this key to activate the Hanning filter.
 - Hamming** - Press this key to activate the Hamming filter.
 - Gaussian** - Press this key to activate the Gaussian filter with the roll-off factor (alpha) of 3.5.
 - Blackman** - Press this key to activate the Blackman filter.
 - Blackman Harris** - Press this key to activate the Blackman Harris filter.
 - K-B 70dB/90dB/110dB (Kaiser-Bessel)** - Select one of the

Kaiser-Bessel filters with sidelobes at -70 , -90 , or -110 dBc.

- **FFT Size** - Allows you to access the menu to change the following parameters:
 - Length Ctrl** - Allows you to toggle the FFT and window length setting function between **Auto** and **Man** (manual).
 - Min Pts in RBW** - Allows you to set the minimum number of data points that will be used inside the resolution bandwidth. The range is 0.10 to 100.00 points with 0.01 resolution. This key is grayed out if **Length Ctrl** is set to **Man**.
 - Window Length** - Allows you to enter the FFT window length in the number of capture samples, ranging from 8 to 1048576. This length represents the actual quantity of I/Q samples that are captured for processing by the FFT (“Capture Time” is the associated parameter shown on the screen). This key is grayed out if **Length Control** is set to **Auto**.
 - FFT Length** - Allows you to enter the FFT length in the number of captured samples, ranging from 8 to 1048576. The FFT length setting is automatically limited so that it is equal to or greater than the FFT window length setting. Any amount greater than the window length is implemented by zero-padding. This key is grayed out if **Length Control** is set to **Auto**.
- **ADC Range** - Allows you to access the menu to define one of the following ADC ranging functions:
 - Auto** - Select this to set the ADC range automatically. For most FFT spectrum measurements, the auto feature should not be selected. An exception is when measuring a signal which is “bursty”, in which case auto can maximize the time domain dynamic range, if FFT results are less important to you than time domain results.
 - Auto Peak** - Select this to set the ADC range automatically to the peak signal level. Auto peak is a compromise that works well for both CW and burst signals.
 - Auto Peak Lock** - Select this to hold the ADC range automatically at the peak signal level. Auto peak lock is more stable than auto peak for CW signals, but should not be used for “bursty” signals.
 - Manual** - Allows you to access the selection menu of values, -6 to $+24$ dB for E4406A or None to $+18$ dB for PSA, to set the ADC range level. Also note that manual ranging is best for CW signals.
- **Data Packing** - Allows you to select **Auto** (the default) or the **Short (16 bit)**, **Medium (24 bit)** and **Long (32 bit)** methods of data packing.

The short, medium, and long methods are not compatible with all settings and should not be used unless you are familiar with data packing methods. **Auto** is the preferred choice.

- Auto** - The data packing value most appropriate for current instrument settings is selected automatically.
 - Short (16 bit)** - Select this to pack data every 16 bits.
 - Medium (24 bit)** - Select this to pack data every 24 bits.
 - Long (32 bit)** - Select this to pack data every 32 bits.
- **ADC Dither** - Allows you to toggle the ADC dither function between **Auto**, **On**, and **Off**. When set to **Auto** (the default), the ADC dither function will be activated when a narrow bandwidth is being measured, and deactivated when a wide bandwidth is being measured. “ADC dither” refers to the introduction of noise to the digitized steps of the analog-to-digital converter; the result is an improvement in amplitude accuracy. Use of the ADC dither, however, reduces dynamic range by approximately 3 dB.
 - **Decimation** - Allows you to toggle the decimation function between **Auto** and **Man**, and to set the decimation value. **Auto** is the preferred setting, and the only setting that guarantees alias-free FFT spectrum measurements. If you are familiar with the decimation feature, you can change the decimation value by setting to **Man**, but be aware that aliasing can result in higher values. Decimation numbers 1 to 1000 describe the factor by which the number of points are reduced. The default setting is 0, which results in no data point reduction. Decimation by 3 keeps every 3rd sample, throwing away the 2 in between.
 - **IF Flatness** - Allows you to toggle the IF flatness function between **On** and **Off**. If set to **On** (the default), the IF flatness feature causes background amplitude corrections to be performed on the FFT spectrum. The **Off** setting is used for adjustment and troubleshooting of the test instrument.

Changing the View

The View/Trace key allows you to select the desired view of the measurement from the following. You can use the Next Window key to move between the multiple windows (if any) and make it full size by Zoom.

- **Spectrum** - Provides a combination view of the spectrum graph in parameters of power versus frequency with the semi-log graticules, and the I/Q waveform graph in the parameters of voltage and time. Changes to frequency span or power will sometimes affect data acquisition.
- **I/Q Waveform** - (for PSA) Provides a view of the I/Q waveform graph

in parameters of voltage versus time in linear scale. Changes to sweep time or resolution bandwidth can affect data acquisition.

- **Spectrum Linear** - (for E4406A) Provides a view of the linear spectrum graph in parameters of voltage and versus frequency with the linear graticules. Changes to frequency span or voltage will sometimes affect data acquisition.

Figure 4-30 Spectrum Measurement - Linear Spectrum View (for E4406A)

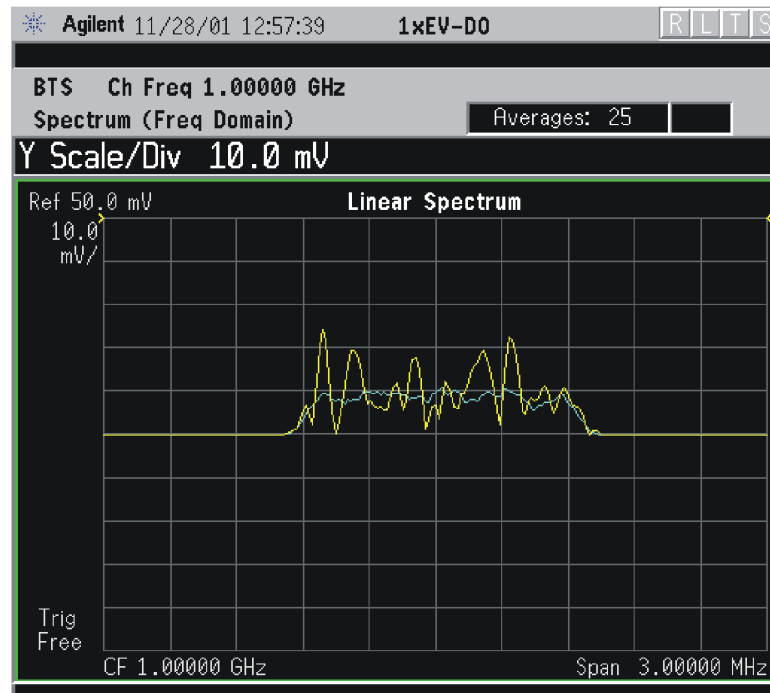

*Meas Setup: View/Trace = Spectrum Linear,
 Span = 3.000 MHz,
 Y Scale/Div = 10.00 mV, Ref Value = 50.0 mV,
 Others = Factory default settings

*Input signals: -10.00 dBm, Pilot channel, 1xEV-DO

- **I/Q Waveform** - Provides a window view of the I/Q waveform graph in parameters of voltage versus time in the linear graticules. Changes to sweep time or resolution bandwidth will sometimes affect data acquisition. This is equivalent to change the selected window with the **Next** key.
- **I and Q Waveform** - (for E4406A) Provides the individual views of the I and Q signal waveform windows in the parameters of voltage versus time.

Figure 4-31 Spectrum Measurement - I and Q Waveform View (for E4406A)

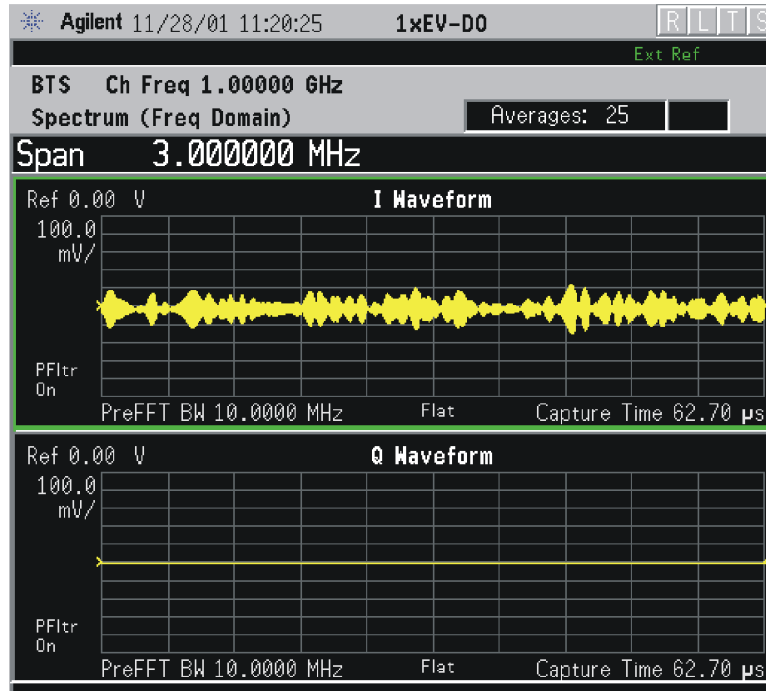

*Meas Setup: View/Trace = I and Q Waveform,
Others = Factory default settings

*Input signals: -10.00 dBm, Pilot channel, 1xEV_DO

- **I/Q Polar** - (for E4406A) Provides a view of the I/Q signal polar vector graph.

Figure 4-32 Spectrum Measurement - I/Q Polar View (for E4406A)

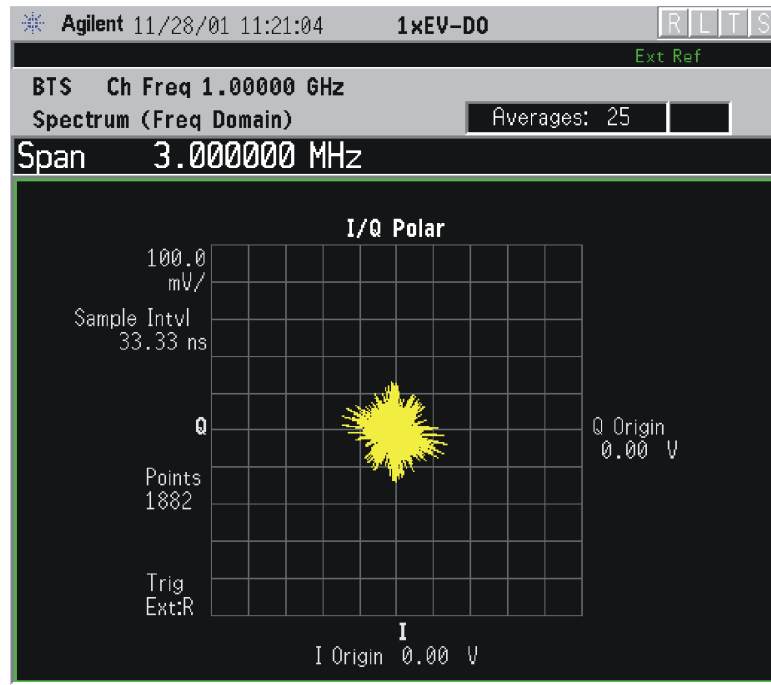

*Meas Setup: View/Trace = I/Q Polar,
 Others = Factory default settings

*Input signals: -10.00 dBm, Pilot channel, 1xEV-DO

Changing the Display

The **Span** key under the **Meas Setup** menu controls the horizontal span of the spectrum window. If the **SPAN X Scale** key is pressed, this **Span** key is activated, while the **AMPLITUDE Y Scale** key allows you to access the menus to modify the vertical parameters depending on the selected windows.

Changing the Spectrum Display

If the Spectrum or Linear Spectrum (for E4406A) window is active in the **Spectrum** or **Spectrum Linear** (for E4406A) view, the **SPAN X Scale** and **AMPLITUDE Y Scale** keys access the menus to modify the following parameters:

- With the **SPAN X Scale** key:
 - **Span** - Allows you to modify the frequency span. The range is 10.000 Hz to 10.000 MHz with 1 Hz resolution, depending on the **Res BW** setting. Changing the span causes the resolution bandwidth to change automatically, and will affect data acquisition time.
- With the **AMPLITUDE Y Scale** key:

- **Scale/Div** - Allows you to set the vertical scale by changing an amplitude value per division. The range is 0.10 dB to 20.00 dB per division or 1.00 nV to 20.00 V per division, respectively. The default setting is 10.00 dB or 100.0 mV. However, since the **Scale Coupling** default is **On**, this value is automatically determined by the measurement results. When you set a value manually, **Scale Coupling** automatically changes to **Off**.
- **Ref Value** - Allows you to set the reference value ranging from -250.00 to 250.00 dBm or -250.00 to 250.00 V. The default setting is 0.00 dBm or 0.00 V. However, since the **Scale Coupling** default is **On**, this value is automatically determined by the measurement results. When you set a value manually, **Scale Coupling** automatically changes to **Off**.
- **Ref Position** - Allows you to set the reference position to either **Top**, **Ctr** (center) or **Bot** (bottom). The default setting is **Ctr**.
- **Scale Coupling** - Allows you to toggle the scale coupling function between **On** and **Off**. The default setting is **On**. Upon pressing the **Restart** front-panel key or **Restart** softkey under the **Meas Control** menu, this function automatically determines the scale per division and reference values based on the measurement results. When you set a value to either **Scale/Div** or **Ref Value** manually, **Scale Coupling** automatically changes to **Off**.

Changing the I or Q Waveform Window (for E4406A)

If the I or Q Waveform window is active in the I and Q Waveform view, the **SPAN X Scale** and **AMPLITUDE Y Scale** keys access the menu to modify the following parameters:

- With the **SPAN X Scale** key:
 - **Scale/Div** - Allows you to set the horizontal scale by changing a time value per division. The range is 1.00 ns to 1.00 s per division. The default setting is 18.8 ms per division. However, since the **Scale Coupling** default is **On**, this value is automatically determined by the measurement results. When you set a value manually, **Scale Coupling** automatically changes to **Off**.
 - **Ref Value** - Allows you to set the reference value ranging from -1.00 to 10.0 s. The default setting is 0.00 s. However, since the **Scale Coupling** default is **On**, this value is automatically determined by the measurement results. When you set a value manually, **Scale Coupling** automatically changes to **Off**.
 - **Ref Position** - Allows you to set the reference position to either **Left**, **Ctr** (center) or **Right**. The default setting is **Left**.
 - **Scale Coupling** - Allows you to toggle the scale coupling function between **On** and **Off**. The default setting is **On**. Upon pressing the **Restart** front-panel key or **Restart** softkey under the **Meas Control**

menu, this function automatically determines the scale per division and reference values based on the measurement results. When you set a value to either **Scale/Div** or **Ref Value** manually, **Scale Coupling** automatically changes to **Off**.

- With the **AMPLITUDE Y Scale** key:
 - **Scale/Div** - Allows you to set the vertical scale by changing the amplitude value per division. The range is 1.00 nV to 20.00 V per division. The default setting is 100.0 mV. However, since the **Scale Coupling** default is **On**, this value is automatically determined by the measurement results. When you set a value manually, **Scale Coupling** automatically changes to **Off**.
 - **Ref Value** - Allows you to set the reference value ranging from -250.00 to 250.00 V. The default setting is 0.00 V. However, since the **Scale Coupling** default is **On**, this value is automatically determined by the measurement results. When you set a value manually, **Scale Coupling** automatically changes to **Off**.
 - **Ref Position** - Allows you to set the reference position to either **Top**, **Ctr** (center) or **Bot** (bottom). The default setting is **Ctr**.
 - **Scale Coupling** - Allows you to toggle the scale coupling function between **On** and **Off**. The default setting is **On**. The **Restart** front-panel key or **Restart** softkey under the **Meas Control** menu, this function automatically determines the scale per division and reference values by the measurement results. When you set a value to either **Scale/Div** or **Ref Value** manually, **Scale Coupling** automatically changes to **Off**.

Changing the I/Q Polar Window (for E4406A)

If the I/Q Polar window is active in the I/Q Polar view, the **SPAN X Scale** key or the **AMPLITUDE Y Scale** key access a menu to modify the following parameters:

- **I/Q Scale/Div** - Allows you to set the vertical and horizontal scales by changing the value per division. The range is 1.00 nV to 20.00 V per division. The default setting is 100.0 mV.
- **I Origin** or **Q Origin** - Allows you to set the reference value ranging from -250.00 to 250.00 V. The default setting is 0.00 V.

Selecting Displayed Traces Within Windows

The **View/Trace** key allows you to access the **Trace Display** key to reveal the trace selection menu. The currently selected trace type is shown on the **Trace Display** key.

- **All** - Allows you to view both the current trace and the average trace.
- **Average** - Allows you to view only the average trace (in blue color).

- **Current** - Allows you to view only the trace (in yellow color) for the latest data acquisition.
- **I Trace** - (for E4406A) Allows you to view only the I signal trace.
- **Q Trace** - (for E4406A) Allows you to view only the Q signal trace.

Using the Markers

The **Marker** front-panel key accesses the menu to configure the markers. If you want to use the marker function in the I waveform window, press **View/Trace, I and Q Waveform, Marker, Trace, I Waveform**.

- **Select 1 2 3 4** - Allows you to activate up to four markers with the corresponding numbers, respectively. The selected number is underlined and its function is defined by pressing the **Function** key. The default is 1.
- **Normal** - Allows you to activate the selected marker to read the frequency and amplitude of the marker position on the spectrum trace. Marker position is controlled by the **RPG** knob.
- **Delta** - Allows you to read the differences in frequencies and amplitudes between the selected marker and the next.
- **Function Off** - Allows you to define the selected marker function to be **Band Power, Noise, or Off**. The default is **Off**. If set to **Band Power**, you need to select **Delta**.
- **Trace Spectrum** - Allows you to place the selected marker on the **Spectrum, Spectrum Avg, Spectrum Linear** (for E4406A), **Spectrum Avg Linear** (for E4406A), **I/Q Waveform, I Waveform** (for E4406A), **Q Waveform** (for E4406A) trace. The default is **Spectrum**.
- **Off** - Allows you to turn off the selected marker.
- **Shape Diamond** - Allows you to access the menu to define the selected marker shape to be **Diamond, Line, Square, or Cross**. The default shape is **Diamond**.
- **Marker All Off** - Allows you to turn off all of the markers.

The front panel **Search** key performs a peak search when pressed. A marker will automatically be activated at the highest peak.

Measuring Band Power

A band power measurement using the markers calculates the average power between two adjustable markers. To make a band power measurement:

1. Press the **Marker** key.
2. Press **Trace, Spectrum** to activate a marker on the instantaneous spectrum signal.

3. Press the **Spectrum Avg** key to activate a marker on the average spectrum trace.
4. Press **Function, Band Power**.
5. Two marker lines are activated at the extreme left side of the horizontal scale. Press **Normal** and move marker 1 to the desired place by rotating the **RPG** knob.
6. Press **Delta** to bring marker 2 to the same place as marker 1.
7. Move marker 1 to the other desired position by rotating the **RPG** knob. Band power measures the average power between the two markers.
8. When the band power markers are active, the results are shown in the results window as `Mean Pwr (Between Mks)`. When the band power function is off the results window reads `Mean Pwr (Entire Trace)`.

Troubleshooting Hints

Changes made by the user to advanced spectrum settings, particularly to ADC range settings, can inadvertently result in spectrum measurements that are invalid and cause error messages to appear. Care needs to be taken when using advanced features.

Making the Waveform (Time Domain) Measurement

Purpose

The waveform measurement is a generic measurement for viewing the input signal waveforms in the time domain. This measurement is how the instrument performs the zero span functionality found in traditional spectrum analyzers.

Basic mode waveform measurement data may be displayed using either a Signal Envelope window, or an I/Q window which shows the I and Q signal waveforms in parameters of voltage versus time. The advantage of having an I/Q view available while making a waveform measurement is that it allows you to view complex components of the same signal without changing settings or measurements.

For E4406A, an I/Q Polar display is also available to view the I and Q waveforms in a polar plot. This display shows the instantaneous relationship between the I and Q waveform voltages.

The waveform measurement can be used to perform general purpose power measurements in the time domain with excellent accuracy.

Measurement Method

The instrument makes repeated power measurements at a set frequency, similar to the way a swept-tuned spectrum analyzer makes zero span measurements. The input analog signal is converted to a digital signal, which then is processed into a representation of a waveform measurement. The measurement relies on a high rate of sampling to create an accurate representation of a time domain signal.

Making the Measurement

NOTE

The factory default parameters provide a good starting point. You may want to change some of the settings. Press **Meas Setup, More, Restore Meas Defaults** at any time to return all parameters for the current measurement to their default settings.

Press **MEASURE, Waveform (Time Domain)** to immediately make a waveform (time domain) measurement.

To change any of the measurement parameters from the factory default values, refer to the “Changing the Measurement Setup” section for this measurement.

Results

The next figure shows an example of an RF Envelope (for E4406A) or Signal Envelope (for PSA) result for the waveform (time domain) measurements in the graph window. The measured values for the mean power and peak-to-mean power are shown in the text window.

Figure 4-33

Waveform Measurement - RF Envelope View

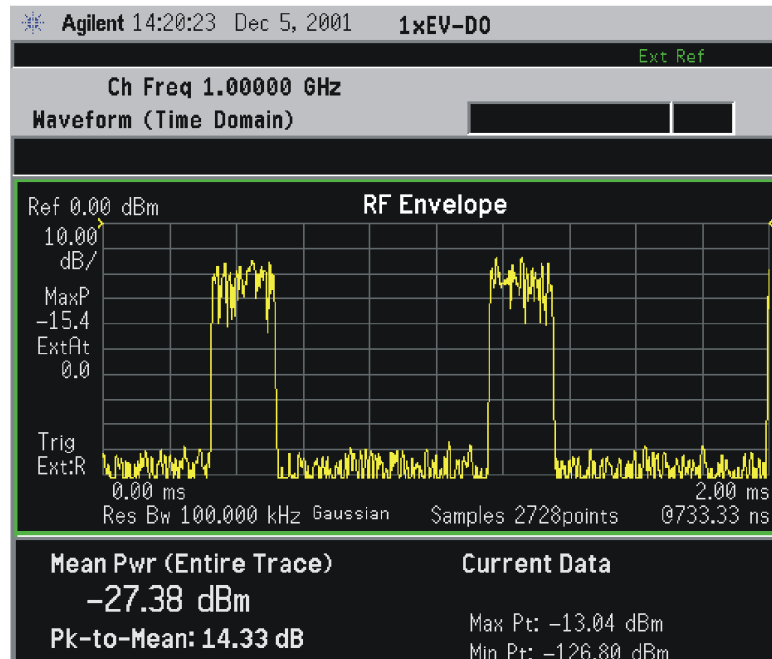

Making Measurements

*Meas Setup: View/Trace = RF Envelope,
 Trigger Source = Ext Rear,
 Others = Factory default settings

*Input signal: -10 dBm, Idle slot, 1xEV-DO

Changing the Measurement Setup

This table shows the factory default settings for waveform (time domain) measurements.

Table 4-16

Waveform (Time Domain) Measurement Defaults

Measurement Parameter	Factory Default Condition
View/Trace	RF Envelope (for E4406A)
Sweep Time	2.000 ms
Res BW	100.000 kHz

Table 4-16 Waveform (Time Domain) Measurement Defaults

Measurement Parameter	Factory Default Condition
Averaging: Avg Number Avg Mode Avg Type	10; Off Exp Pwr Avg (RMS)
Trig Source	Free Run (Immediate)
RF Envelope View SPAN X Scale - Scale/Div AMPLITUDE Y Scale - Scale/Div	(for E4406A) 200.0 μ s 10.00 dB
Signal Envelope View SPAN X Scale - Scale/Div AMPLITUDE Y Scale - Scale/Div	(for PSA) 200.0 μ s 10.00 dB
I/Q Waveform View: SPAN X Scale -Scale/Div AMPLITUDE Y Scale - Scale/Div	200.0 μ s 100.0 mV
I/Q Polar View: I/Q Scale/Div I or Q Origin	(for E4406A) 100.0 mV 0.00 V
Advanced	
Pre-ADC BPF	Off
RBW Filter	Gaussian
ADC Range	Auto
Data Packing	Auto
ADC Dither	Off
Decimation	Off

NOTE Parameters that are under the **Advanced** key seldom need to be changed. Any changes from the default values may result in invalid measurement data.

Make sure the **Waveform (Time Domain)** measurement is selected under the **MEASURE** menu. Press the **Meas Setup** key to access a menu which allows you to modify the averaging, and trigger source for this measurement (as described in the “Measurement Setup” section).

In addition, the following parameters can be modified:

- **Sweep Time** - Allows you to specify the measurement acquisition time which is used as the length of the time capture record. The range is 1.0 μ s and 100.0 s, depending upon the resolution bandwidth setting and the available internal memory size for acquisition points.

- **Res BW** - Allows you to set the measurement bandwidth. The range is 10 Hz to 8 MHz using the **Gaussian** filter selected from **RBW Filter** under the **Advanced** menu, or 10 Hz to 10 MHz using the **Flat** top filter selected from **RBW Filter**. A larger bandwidth results in a larger number of acquisition points and reduces the maximum value allowed for the sweep time.
- **Advanced** - Allows you to access the menu to change the following parameters. Changes from the default values may result in invalid data.
 - **Pre-ADC BPF** - Allows you to toggle the pre-ADC bandpass filter function between **On** or **Off**. The default setting is **Off**. The pre-ADC bandpass filter is useful for rejecting nearby signals, so that sensitivity within the span range can be improved by increasing the ADC range gain.
 - **RBW Filter** - Allows you toggle the resolution bandwidth filter selection between **Flat** and **Gaussian**. If set to **Gaussian**, the filter provides more even time-domain response, particularly for “bursts”. If set to **Flat**, the filter provides a flatter bandwidth but is less accurate for “pulse responses”. A flat top filter also requires less memory and allows longer data acquisition times. For most waveform applications, the Gaussian filter is recommended. The resolution bandwidth range is 10 Hz to 8 MHz using the Gaussian filter or 10 Hz to 10 MHz using the Flat top filter.
 - **ADC Range** - Allows you to access the menu to select one of the ADC ranging functions:
 - Auto** - Select this to cause the instrument to automatically adjust the signal range for optimal measurement results.
 - AutoPeak** - Select this to cause the instrument to continuously seek the highest peak signal.
 - AutoPeakLock** - Select this to cause the instrument to adjust the range for the highest peak signal it identifies, and retains the range settings determined by that peak signal, even when the peak signal is no longer present.
 - Manual** - Allows you to access the selection menu of values, -6 to +24 dB for E4404A or None to +18 dB for PSA, to set the ADC range level. Also note that manual ranging is best for CW signals.
 - **Data Packing** - Allows you to select **Auto** (the default) or the **Short (16 bit)**, **Medium (24 bit)** and **Long (32 bit)** methods of data packing. The short, medium, and long methods are not compatible with all settings and should not be used unless you are familiar with data packing methods. **Auto** is the preferred choice.
 - Auto** - The data packing value most appropriate for current

instrument settings is selected automatically.

- Short (16 bit)** - Select this to pack data every 16 bits.
- Medium (24 bit)** - Select this to pack data every 24 bits.
- Long (32 bit)** - Select this to pack data every 32 bits.
- **ADC Dither** - Allows you to toggle the ADC dither function between **On** and **Off**. The default setting is **Off**. If set to **On**, the ADC dither refers to the introduction of noise to the digitized steps of the analog-to-digital converter, and results in better amplitude linearity and resolution in low level signals. However, it also results in reduced dynamic range by approximately 3 dB.
- **Decimation** - Allows you to toggle the decimation function between **On** and **Off**, and to set the decimation value. Decimation allows longer acquisition times for a given bandwidth by eliminating data points. Long time captures can be limited by the instrument data acquisition memory. Decimation numbers 1 to 4 describe the factor by which the number of points are reduced. The default setting is 1, which results in no data point reduction.

Changing the View

The **View/Trace** key allows you to access the selection menu for the desired measurement view. You can use the **Next Window** key to move between the multiple windows (if any) and make it full size by **Zoom**.

Windows Available for Waveform Measurements

The following views are available to display measurement data, and are accessed by pressing the **Trace/View** (for PSA) or **View/Trace** (for E4406A) key:

- **RF Envelope** (for E4406A) or **Signal Envelope** (for PSA) - Provides a combination view of the waveform graph in parameters of power versus time with semi-log graticules. The measurement results for Mean Pwr (Entire Trace), Pk-to-Mean, Current Data for Max Pt and Min Pt are shown in the text window as shown in [“Results” on page 255](#). Changes to sweep time or resolution bandwidth can affect data acquisition.
- **I/Q Waveform** - Provides a view of the I/Q waveform graph in parameters of voltage versus time in linear scale. Changes to sweep time or resolution bandwidth can affect data acquisition.

NOTE

For the widest spans the I/Q Waveform window becomes just “ADC time domain samples”, because the I/Q down-conversion is no longer in effect.

NOTE

For the widest spans the I/Q Waveform window becomes just “ADC time

domain samples”, because the I/Q down-conversion is no longer in effect.

Figure 4-34 Waveform Measurement - I/Q Waveform View

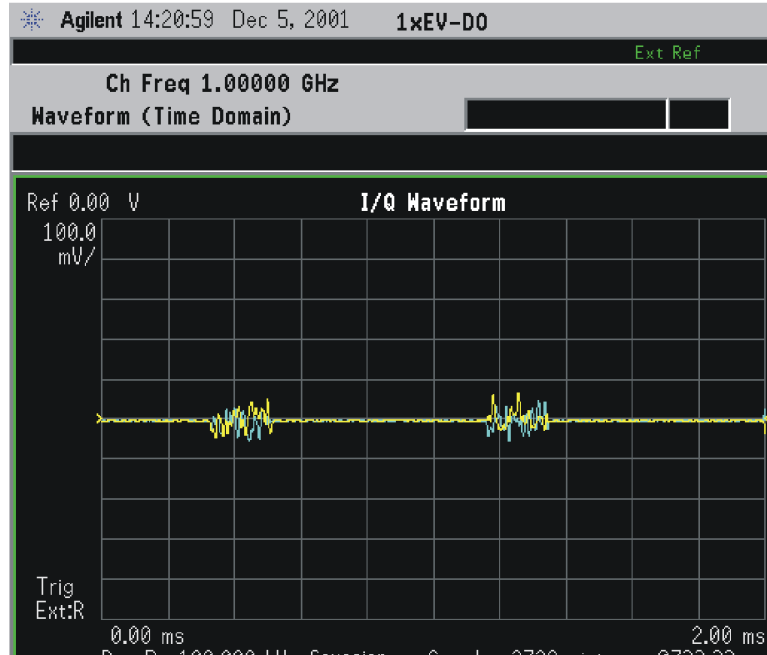

Making Measurements

*Meas Setup: View/Trace = I/Q Waveform,
Trigger Source = Ext Rear,
Others = Factory default settings

*Input signal: -10 dBm, Idle slot, 1xEV-DO

- **I/Q Polar** - (for E4406A) Provides a view of the I/Q signal in a polar vector graph.

Figure 4-35 Waveform Measurement - I/Q Polar View

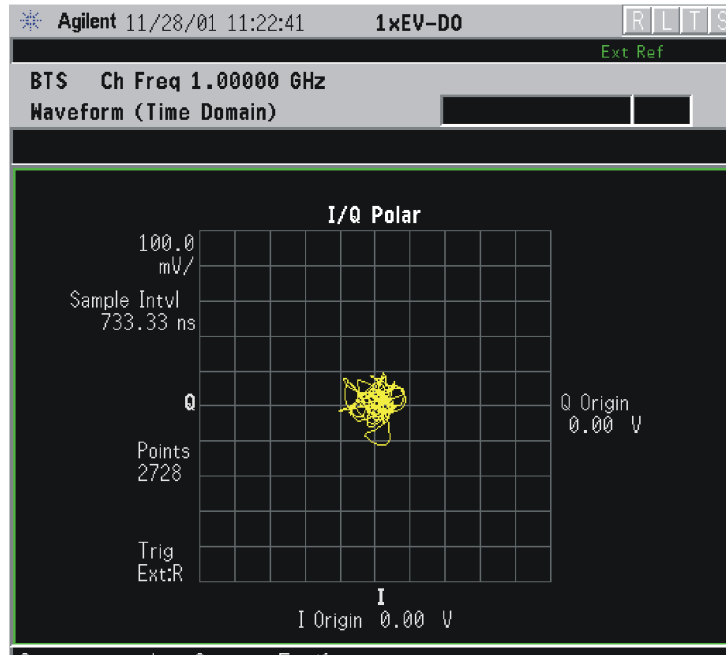

*Meas Setup: View/Trace = I/Q Polar,
Trigger Source = Ext Rear,
Others = Factory default settings

*Input signal: -10 dBm, Idle slot, 1xEV-DO

Changing the Display

The **Sweep Time** key under the **Meas Setup** menu controls the horizontal time span for this measurement, while the **SPAN X Scale** key allows you to access the menu to modify the horizontal parameters common to the rectangular windows for this measurement:

- **Scale/Div** - Allows you to set the horizontal scale by changing a time value per division. The range is 1.0 ns to 1.000 s per division with 0.01 ns resolution. The default setting is 200.0 μ s per division. However, since the **Scale Coupling** default is **On**, this value is automatically determined by the measurement result. When you set a value manually, **Scale Coupling** automatically changes to **Off**.
- **Ref Value** - Allows you to set the reference value ranging from -1.0 to 10.0 s. The default setting is 0.00 s. However, since the **Scale Coupling** default is **On**, this value is automatically determined by the measurement result. When you set a value manually, **Scale Coupling** automatically changes to **Off**.
- **Ref Position** - Allows you to set the reference position to either **Left**, **Ctr** (center) or **Right**. The default setting is **Left**.
- **Scale Coupling** - Allows you to toggle the scale coupling function

between **On** and **Off**. The default setting is **On**. Upon pressing the **Restart** front-panel key or **Restart** softkey under the **Meas Control** menu, this function automatically determines the scale per division and reference values based on the measurement results. When you set a value to either **Scale/Div** or **Ref Value** manually, **Scale Coupling** automatically changes to **Off**.

If the RF Envelope (for E4406A) or Signal Envelope (for PSA) window is active in the **RF Envelope** (for E4406A) or **Signal Envelope** (for PSA) view, the **AMPLITUDE Y Scale** key accesses the menu to modify the following parameters:

- **Scale/Div** - Allows you to set the vertical scale by changing an amplitude value per division. The range is 0.10 to 20.00 dB per division with 0.01 dB resolution. The default setting is 10.00 dB per division. However, since the **Scale Coupling** default is **On**, this value is automatically determined by the measurement result. When you set a value manually, **Scale Coupling** automatically changes to **Off**.
- **Ref Value** - Allows you to set the reference value ranging from -250.00 to 250.00 dBm. The default setting is 0.00 dBm. However, since the **Scale Coupling** default is **On**, this value is automatically determined by the measurement result. When you set a value manually, **Scale Coupling** automatically changes to **Off**.
- **Ref Position** - Allows you to set the reference position to either **Top**, **Ctr** (center) or **Bot** (bottom). The default setting is **Top**.
- **Scale Coupling** - Allows you to toggle the scale coupling function between **On** and **Off**. The default setting is **On**. Upon pressing the **Restart** front-panel key or **Restart** softkey under the **Meas Control** menu, this function automatically determines the scale per division and reference values based on the measurement results. When you set a value to either **Scale/Div** or **Ref Value** manually, **Scale Coupling** automatically changes to **Off**.

If the I/Q Waveform window is active in the **I/Q Waveform** view, the **AMPLITUDE Y Scale** key accesses the menu to modify the following parameters:

- **Scale/Div** - Allows you to set the vertical scale by changing an amplitude value per division. The range is 1.00 nV to 20.00 V per division. The default setting is 100.0 mV. However, since the **Scale Coupling** default is **On**, this value is automatically determined by the measurement result. When you set a value manually, **Scale Coupling** automatically changes to **Off**.
- **Ref Value** - Allows you to set the reference value ranging from -250.00 to 250.00 V. The default setting is 0.00 V. However, since the **Scale Coupling** default is **On**, this value is automatically determined by the measurement result. When you set a value manually, **Scale Coupling** automatically changes to **Off**.

- **Ref Position** - Allows you to set the reference position to either **Top**, **Ctr** (center) or **Bot** (bottom). The default setting is **Ctr**.
- **Scale Coupling** - Allows you to toggle the scale coupling function between **On** and **Off**. The default setting is **On**. Upon pressing the **Restart** front-panel key or **Restart** softkey under the **Meas Control** menu, this function automatically determines the scale per division and reference values based on the measurement results. When you set a value to either **Scale/Div** or **Ref Value** manually, **Scale Coupling** automatically changes to **Off**.

For E4406A, if the I/Q Polar window is active in the **I/Q Polar** view, the **SPAN X Scale** or **AMPLITUDE Y Scale** key accesses the menu to modify the following parameters:

- **I/Q Scale/Div** - Allows you to set the vertical and horizontal scales by changing a value per division. The range is 1.00 nV to 20.00 V per division. The default setting is 100.0 mV.
- **I or Q Origin** - Allows you to set the reference value ranging from -250.00 to 250.00 V. The default setting is 0.00 V.

The **Display** key is not available for this measurement.

Using the Markers

The **Marker** front-panel key accesses the menu to configure the markers.

- **Select 1 2 3 4** - Allows you to activate up to four markers with the corresponding numbers, respectively. The selected number is underlined and its function is defined by pressing the **Function** key. The default is 1.
- **Normal** - Allows you to activate the selected marker to read the time position and amplitude of the marker on the RF envelope or Signal Envelope trace. Marker position is controlled by the **RPG** knob.
- **Delta** - Allows you to read the differences in time positions and amplitudes between the selected marker and the next.
- **Function Off** - Allows you to define the selected marker function to be **Band Power**, **Noise**, or **Off**. The default is **Off**. If set to **Band Power**, you need to select **Delta**.
- **Trace** - Allows you to place the selected marker on **RF Envelope** (for E4406A), **Signal Envelope** (for PSA), or **I/Q Waveform**.
- **Off** - Allows you to turn off the selected marker.
- **Shape Diamond** - Allows you to access the menu to define the selected marker shape to be **Diamond**, **Line**, **Square**, or **Cross**. The default shape is **Diamond**.
- **Marker All Off** - Allows you to turn off all of the markers.

The front panel **Search** key performs a peak search when pressed. A marker will automatically be activated at the highest peak.

NOTE

In the Waveform measurement, the Mean Pwr (Entire Trace) value plus the Pk-to-Mean value will sum to equal the current Max Pt. value as shown in the data window below the RF Envelope or Signal Envelope display. If you do a marker peak search (**Search**) with averaging turned off, the marker will find the same maximum point. However, if you turn averaging on, the Pk-to-Mean value will use the highest peak found for any acquisition during averaging, while the marker peak will look for the peak of the display, which is the result of n-averages. This will usually result in differing values for the maximum point.

Troubleshooting Hints

Changes made to advanced waveform settings can inadvertently result in measurements that are invalid and cause error messages to appear. Care needs to be taken when using advanced features, as some settings may incorrectly appear to provide a valid result. Use the Meas Setup, More, Restore Meas Defaults function to return the measurement settings to a known state, and then vary settings only as necessary.

Making Measurements
Making the Waveform (Time Domain) Measurement

5 Programming Commands

These commands are only available when the 1xEV-DO mode has been selected using `INSTRument:SElect CDMA1XEV`. If this mode is selected, commands that are unique to another mode are not available.

SCPI Command Subsystems

- “CALCulate Subsystem” on page 272
- “CONFigure Subsystem” on page 316
- “DISPlay Subsystem” on page 317
- “FETCh Subsystem” on page 331
- “FORMat Subsystem” on page 332
- “INITiate Subsystem” on page 334
- “INSTrument Subsystem” on page 336
- “MEASure Group of Commands” on page 339
- “READ Subsystem” on page 410
- “SENSe Subsystem” on page 411
- “TRIGger Subsystem” on page 536

Programming Command Compatibility Across Model Numbers and Across Modes

Across PSA Modes: Command Subsystem Similarities

When you select different modes you get different sets of available programming commands. That is, *only* the commands that are appropriate for the current mode are available. Also, some commands have the same syntax in different modes but have different ranges or settings that are only appropriate to the current mode.

The following table shows which command subsystems are the same across different modes. If there is no “X” by a particular subsystem, then the set of available commands is different in those modes. Command ranges or defaults may also be different. Refer to the programming command descriptions in the documentation for each mode for details.

Command Subsystem	Same command set is available: SA mode compared with the application modes: W-CDMA, cdmaOne, cdma2000, 1xEV-DO, Basic, GSM, EDGE, NADC, or PDC	Same command set is available: SA mode compared with the application mode: Phase Noise
IEEE common commands	X	X
ABORt	X	X
CALCulate		
CALibration	X	X
CONFigure		
COUPle	not available in these application modes	not available in this application modes
DISPlay		
FETCh		
FORMat		X
HCOPy	X	X
INITiate		
INPut	not available in these application modes	X

Command Subsystem	Same command set is available: SA mode compared with the application modes: W-CDMA, cdmaOne, cdma2000, 1xEV-DO, Basic, GSM, EDGE, NADC, or PDC	Same command set is available: SA mode compared with the application mode: Phase Noise
MEASure		
MEMory	X	X
MMEMory	X	X
MMEMory:STORe:TRACe	not available in application modes	X
READ		
[SENSe] [SENSe:]CHANnel [SENSe:]CORRection [SENSe:]FEED [SENSe:]FREQUency:CENTer [SENSe:]FREQUency: <other subsystems> [SENSe:]<measurement> [SENSe:]POWer [SENSe:]RADio [SENSe:]SYNC	X not available in application modes	 not available in application modes
STATus	X	X
SYSTem	X	X
TRACe	not available in application modes	X
TRIGger		
UNIT	X	X

Across PSA Modes: Specific Command Differences

Some programming commands operate differently depending on which Mode the analyzer is set to.

Command	Spectrum Analysis, Phase Noise and Noise Figure Mode	Basic, cdmaOne, cdma2000, 1xEV-DO, W-CDMA, GSM, EDGE, NADC, PDC Modes
CONFigure: <measurement>	Accesses the measurement and sets the instrument settings to the defaults. Averaging is turned on and set to 10. The instrument is put in single measurement mode. It does not initiate a measurement. Use INIT:IMM to make one measurement.	Accesses the measurement and sets the instrument settings to the defaults. If you were already in single measurement mode, it takes one measurement and then waits. If you were in continuous measurement mode it continues to measure.
*ESE default	Default is 255 which means that every error/status bit change that has occurred will be returned with a *ESR? query. You must set the value of *ESE to choose only the bits/status that you want returned.	Default is 0 which means that none of the error/status bit changes that have occurred will be returned with a *ESR? query. You must set the value of *ESE to choose the bits/status that you want returned.
TRIGger commands	For these modes, only one trigger source can be selected and it will be common across the modes. Also, only one value can be set for the trigger delay, level, or polarity.	For these modes, a unique trigger source can be selected for each mode. Also, each trigger source can have unique settings for the its delay, level, and polarity.
Saving and recalling traces	Traces can only be saved when in the Spectrum Analysis mode (MMEM:STOR:TRAC). This is because the instrument state must be saved along with the trace data and the state data varies depending on the number of modes currently available in the instrument.	

Using Applications in PSA Series vs. VSA E4406A

NOTE

This information *only* applies to the application modes:
Basic, cdmaOne, cdma2000, 1xEV-DO, W-CDMA, GSM, EDGE,
NADC, and PDC.

Command	PSA Series	VSA E4406A: A.04.00	VSA E4406A: A.05.00
*RST	Resets instrument, putting it in continuous measurement mode. Use INIT:CONT OFF to select single measurement mode and INIT:IMM to start one measurement.	Resets instrument, putting it in single measurement mode. One measurement is initiated when the command is sent.	Resets instrument, putting it in single measurement mode. No measurement is initiated when the command is sent. Use INIT:IMM to start one measurement.
CONFigure: <measurement>	Accesses the measurement and sets the instrument settings to the defaults. If you were already in single measurement mode, it takes one measurement and then waits.	Same as PSA. Accesses the measurement and sets the instrument settings to the defaults. If you were already in single measurement mode, it takes one measurement and then waits.	Accesses the measurement and sets the instrument settings to the defaults. If you were already in single measurement mode, it does not initiate a measurement. Use INIT:IMM to make one measurement.
*ESE default	Default is 255 which means that every error/status bit change that has occurred will be returned with a *ESR? query. You must set the value of *ESE to choose only the bits/status that you want returned.	Default is 0 which means that none of the error/status bit changes that have occurred will be returned with a *ESR? query. You must set the value of *ESE to choose the bits/status that you want returned.	Same as VSA A.04.00. Default is 0 which means that none of the error/status bit changes that have occurred will be returned with a *ESR? query. You must set the value of *ESE to choose the bits/status that you want returned.
*LRN	The command is <i>not</i> available.	The command is available.	The command is available.
TRIGger commands	In Spectrum Analysis mode only one value can be set for the trigger's source, delay, level, or polarity. Basic, GSM, EDGE, cdmaOne, cdma2000, W-CDMA, NADC, PDC modes function the same as VSA	You can select a unique trigger source for each mode. Each trigger source can have unique settings for the its delay, level, and polarity.	Same as VSA A.04.00. You can select a unique trigger source for each mode. Each trigger source can have unique settings for the its delay, level, and polarity.

Command	PSA Series	VSA E4406A: A.04.00	VSA E4406A: A.05.00
<p>AUTO ON OFF control and setting manual values</p>	<p>We recommend that you set a function's automatic state to OFF, before you send it your manual value.</p> <p>Some functions will turn off the automatic mode when you send a specific manual value, but others will not. This also varies with the instrument model.</p>	<p>We recommend that you set a function's automatic state to OFF, before you send it your manual value.</p> <p>Some functions will turn off the automatic mode when you send a specific manual value, but others will not. This also varies with the instrument model.</p>	<p>We recommend that you set a function's automatic state to OFF, before you send it your manual value.</p> <p>Some functions will turn off the automatic mode when you send a specific manual value, but others will not. This also varies with the instrument model.</p>

CALCulate Subsystem

This subsystem is used to perform post-acquisition data processing. In effect, the collection of new data triggers the CALCulate subsystem. In this instrument, the primary functions in this subsystem are markers and limits.

The SCPI default for data output format is ASCII. The format can be changed to binary with FORMat:DATA which transports faster over the bus.

Code Domain Power - Limits

Code Domain—Active Set Threshold

```
:CALCulate:CDPower:ASET:THReshold <numeric>
```

```
:CALCulate:CDPower:ASET:THReshold?
```

Set the threshold level for the active channel identification function.

Factory Preset: 0.0 dBm

Range: -100.0 to 0.0 dB

Remarks: You must be in the cdma2000, W-CDMA, or 1xEV-DO mode to use this command. Use INSTRument:SElect to set the mode.

Code Domain—Measurement Channel Type

```
:CALCulate:CDPower:CHANnel:TYPE DATA|MAC|PILot
```

```
:CALCulate:CDPower:CHANnel:TYPE?
```

Set one of the channel types from the following channels:

DATA – the data channel

MAC – the medium access control (MAC) channel

PILot – the pilot channel

Factory Preset: PILot

Remarks: You must be in the 1xEV-DO mode to use this command. Use INSTRument:SElect to set the mode.

Code Domain—I/Q Combined Power

```
:CALCulate:CDPower:IQ:COMBined[:STATe] OFF|ON|0|1
```

:CALCulate:CDPower:IQ:COMBined[:STATe]?

Turn the I/Q Combined Power Bar on or off.

On- compute I/Q combined power bar.

Off- compute I/Q separated power bar.

Factory Preset: Off

Remarks: You must be in the 1xEV-DO mode to use this command. Use INSTRument:SElect to set the mode.

Code Domain—Sweep Offset (Measurement Offset)

:CALCulate:CDPower:SWEep:OFFSet <integer>

:CALCulate:CDPower:SWEep:OFFSet <float> (1xEV-DO only)

:CALCulate:CDPower:SWEep:OFFSet?

1xEV-DO mode:

Set the timing offset of measurement interval in units of slot (1 slot = 1.667 ms).

The sum of **CALCulate:CDPower:SWEep:TIME** and **CALCulate:CDPower:SWEep:OFFSet** must be equal to or less than **SENSe:CDPower:CAPTure:TIME**. If the sum becomes more than the value, **CALCulate:CDPower:SWEep:OFFSet** is adjusted automatically.

cdma2000 mode:

Set the timing offset of measurement interval in units of Power Control Group (PCG; 1 PCG = 1.25 ms).

The sum of **CALCulate:CDPower:SWEep:TIME** and **CALCulate:CDPower:SWEep:OFFSet** must be equal to or less than **SENSe:CDPower:CAPTure:TIME**. If the sum becomes more than the value, **CALCulate:CDPower:SWEep:OFFSet** is adjusted automatically.

W-CDMA mode:

Set the timing offset of measurement interval in slots (1 slot = 625 μ s).

The sum of **CALCulate:CDPower:SWEep:TIME** and **CALCulate:CDPower:SWEep:OFFSet** must be equal to or less than **SENSe:CDPower:CAPTure:TIME** \times 15. If the sum becomes more than the value, **CALCulate:CDPower:SWEep:OFFSet** is adjusted automatically.

Factory Preset: 0

Range: 0 to **SENSe:CDPower:CAPTure:TIME** – 1 for cdma2000
0 to **SENSe:CDPower:CAPTure:TIME** – 0.5 for 1xEV-DO
0 to **SENSe:CDPower:CAPTure:TIME** × 15 – 1 for
W-CDMA

Remarks: You must be in the cdma2000, W-CDMA, or 1xEV-DO mode to use this command. Use **INSTRument:SElect** to set the mode.

Code Domain—Sweep Time (Measurement Interval)

:CALCulate:CDPower:SWEep:TIME <integer>

:CALCulate:CDPower:SWEep:TIME <float> for (1xEV-DO only)

:CALCulate:CDPower:SWEep:TIME?

- For 1xEV-DO

Set the length of measurement interval in units of slot (1 slot = 1.667 ms).

The sum of **CALCulate:CDPower:SWEep:TIME** and **CALCulate:CDPower:SWEep:OFFSet** must be equal to or less than **SENSe:CDPower:CAPTure:TIME**. If the sum becomes more than the value, **CALCulate:CDPower:SWEep:OFFSet** is adjusted automatically.

- For cdma2000

Set the length of measurement interval in the unit of Power Control Group (PCG; 1 PCG = 1.25 ms).

The sum of **CALCulate:CDPower:SWEep:TIME** and **CALCulate:CDPower:SWEep:OFFSet** must be equal to or less than **SENSe:CDPower:CAPTure:TIME**. If the sum becomes more than the value, **CALCulate:CDPower:SWEep:OFFSet** is adjusted automatically.

- For W-CDMA

Set the length of measurement interval in slots (1 slot = 625 μs).

The sum of **CALCulate:CDPower:SWEep:TIME** and **CALCulate:CDPower:SWEep:OFFSet** must be equal to or less than **SENSe:CDPower:CAPTure:TIME** × 15. If the sum becomes more than the value, **CALCulate:CDPower:SWEep:OFFSet** is adjusted automatically.

Factory Preset: 1

Range: 1 to **SENSe:CDPower:CAPTure:TIME** for cdma2000
0.5 to **SENSe:CDPower:CAPTure:TIME** for 1xEV-DO

1 to **SENSe:CDPower:CAPTure:TIME** × 15 for W-CDMA

Remarks: You must be in the cdma2000, W-CDMA, or 1xEV-DO mode to use this command. Use **INSTRument:SElect** to set the mode.

Code Domain—Computation Type

:CALCulate:CDPower:TYPE ABSolute|RELative

:CALCulate:CDPower:TYPE?

Set the code domain power computation type to either the absolute power or the relative value to the mean power.

ABSolute – code domain power is computed as the absolute power.

RELative – code domain power is computed relative to the mean power.

Factory Preset: **RELative**

Remarks: You must be in the cdma2000 , W-CDMA, or 1xEV_DO mode to use this command. Use **INSTRument:SElect** to set the mode.

Code Domain—Data Channel Type

:CALCulate:CDPower:TYPE:DATA OPSK|QAM|QPSK

:CALCulate:CDPower:TYPE:DATA?

Select one of the following data channel types to be used for encoding:

OPSK - 8 phase shift keying (8PSK).

QAM - 16 quadrature phase shift keying (16QAM)

QPSK - Quadrature phase shift keying

Factory Preset: **QPSK**

Remarks: You must be in the 1xEV-DO mode to use this command. Use **INSTRument:SElect** to set the mode.

Code Domain—Walsh Code Number

:CALCulate:CDPower:WCODE[:NUMBER] <integer>

:CALCulate:CDPower:WCODE[:NUMBER]?

Set the Walsh code number depending on the channel type.

Factory Preset: **0**

Range: 0 to CALCulate:CDPower:WCODE:LENGTH – 1, for
cdma2000

0 to 31 for Pilot,
0 to 63 for MAC,
0 to 15 for Data (1xEV-DO)

Remarks: You must be in the cdma2000 or 1xEV-DO mode to use
this command. Use INSTRument:SElect to set the
mode.

Code Domain—Walsh Code Order

:CALCulate:CDPower:WCODE:ORDER BREVerse|HADMrD

:CALCulate:CDPower:WCODE:ORDER?

Set the type of the Walsh code order to either of the following:

BREVerse (Bit Reverse) – In the order to show the higher
(consolidated) spreading code as a single bundle in the CDP display

HADMrD (Hadamard) – Regular order

Factory Preset: Hadamard (HADMrD)

Remarks: You must be in the cdma2000, or 1xEV-DO mode to use
this command. Use INSTRument:SElect to set the
mode.

Terminal Code Domain Measurement

This measurement is used to make Code Domain Power measurements on 1xEV-DO mobile stations (access terminals). To measure 1xEV-DO base stations (network access equipment) use the Code Domain Power measurement.

Terminal Code Domain - Active Set Threshold

```
:CALCulate:TCDPower:ASET:THReshold <numeric>
:CALCulate:TCDPower:ASET:THReshold?
```

Set the threshold level for the active channel identification function.

Factory Preset: 0.0 dBm

Range: -100.0 to 0.0 dB

Remarks: You must be in the 1xEV-DO mode to use this command. Use INSTRument:SElect to set the mode.

Terminal Code Domain - Active Set Threshold Mode

```
:CALCulate:TCDPower:ASET:THReshold:AUTO OFF|ON|0|1
:CALCulate:TCDPower:ASET:THReshold:AUTO?
```

Turn the automatic mode On or Off, for the active channel identification function.

OFF – The active channel identification for each code channel is determined by a value set by CALCulate:RHO:ASET:THReshold.

ON – The active channels are determined automatically with the internal algorithm.

Factory Preset: ON

Remarks: You must be in the 1xEV-DO mode to use this command. Use INSTRument:SElect to set the mode.

Terminal Code Domain - I/Q Branch (Decode Axis)

```
:CALCulate:TCDPower:AXIS IPH|QPH
:CALCulate:TCDPower:AXIS?
```

Select the I phase or Q phase for the demodulation axis.

IPH – I phase

QPH – Q phase

Factory Preset: IPH

Remarks: You must be in the 1xEV-DO mode to use this command. Use INSTRument:SElect to set the mode.

Terminal Code Domain - Sweep Offset (Measurement Offset)

:CALCulate:TCDPower:SWEep:OFFSet <integer>

:CALCulate:TCDPower:SWEep:OFFSet?

Set the timing offset of measurement start in slots to be used (1 slot = 1.667 ms).

Factory Preset: 0

Range: 0 to [:SENSe]:TCDPower:CAPTure:TIME - 0.5

Remarks: You must be in the 1xEV-DO mode to use this command. Use INSTRument:SElect to set the mode.

This number is coupled with **CALCulate:TCDPower:SWEep:TIME**. Since the total acquired data is [:SENSe]:TCDPower:CAPTure:TIME slots, if the sum of **CALCulate:TCDPower:SWEep:OFFSet** plus [:SENSe]:TCDPower:SWEep:TIME becomes more than the value of [:SENSe]:TCDPower:CAPTure:TIME, then **CALCulate:TCDPower:SWEep:TIME** is adjusted automatically.

Terminal Code Domain - Sweep Time (Measurement Interval)

:CALCulate:TCDPower:SWEep:TIME <integer>

:CALCulate:TCDPower:SWEep:TIME?

Set the length of measurement interval in slots to be used (1 slot = 1.667 ms).

Factory Preset: 1

Range: 0 to SENSe:TCDPower:CAPTure:TIME

Remarks: You must be in the 1xEV-DO mode to use this command. Use INSTRument:SElect to set the mode.

This number is coupled with **CALCulate:TCDPower:SWEep:OFFSet**. Since the total acquired data is [:SENSe]:TCDPower:CAPTure:TIME slots, if the sum of **CALCulate:TCDPower:SWEep:OFFSet** plus [:SENSe]:TCDPower:SWEep:TIME becomes more than the value of [:SENSe]:TCDPower:CAPTure:TIME, then **CALCulate:TCDPower:SWEep:OFFSet** is adjusted automatically.

Terminal Code Domain - Measurement Type

:CALCulate:TCDPower:TYPE ABSolute|RELative

:CALCulate:TCDPower:TYPE?

Set the code domain power computation type to either the absolute power or the relative value to the mean power.

ABSolute – code domain power is computed as the absolute power.

RELative – code domain power is computed relative to the mean power.

Factory Preset: RELative

Remarks: You must be in the 1xEV_DO mode to use this command. Use INSTRument:SElect to set the mode.

Terminal Code Domain - Walsh Code Length

```
:CALCulate:TCDPower:WCODE:LENGth <integer>
```

```
:CALCulate:TCDPower:WCODE:LENGth?
```

Set the Walsh Code length.

Factory Preset: 16

Range: 4, 8, 16

Remarks: You must be in the 1xEV-DO mode to use this command. Use INSTRument:SElect to set the mode.

Terminal Code Domain - Walsh Code Number

```
:CALCulate:TCDPower:WCODE[:NUMBER] <integer>
```

```
:CALCulate:TCDPower:WCODE[:NUMBER]?
```

Set the Walsh code number depending on the channel type.

Factory Preset: 0

Range: 0 to CALCulate:TCDPower:WCODE:LENGth – 1

Remarks: You must be in the 1xEV-DO mode to use this command. Use INSTRument:SElect to set the mode.

Terminal Code Domain - Walsh Code Order

```
:CALCulate:TCDPower:WCODE:ORDER BREVerse | (HADamard | HADMrd)
```

```
:CALCulate:TCDPower:WCODE:ORDER?
```

Set the type of the Walsh code order to either of the following:

BREVerse (Bit Reverse) – In the order to show the higher (consolidated) spreading code as a single bundle in the CDP display

HADamard or HADMrd (Hadamard) – Regular order

Factory Preset: Hadamard (HADamard)

Remarks: You must be in the 1xEV-DO mode to use this command. Use INSTRument:SElect to set the mode.

Test Current Results Against all Limits

:CALCulate:CLIMits:FAIL?

Queries the status of the current measurement limit testing. It returns a 0 if the measured results pass when compared with the current limits. It returns a 1 if the measured results fail any limit tests.

Data Query

:CALCulate:DATA [n] ?

Returns the designated measurement data for the currently selected measurement and sub-opcode.

n = any valid sub-opcode for the current measurement. See the “MEASure Group of Commands” on page 339 for information on the data that can be returned for each measurement.

For sub-opcodes that return trace data use the **:CALCulate:DATA [n] :COMPRESS?** command below.

Calculate/Compress Trace Data Query

:CALCulate:DATA<n>:COMPRESS?

BLOCK | CFIT | MAXimum | MEAN | MINimum | RMS | SAMPLE | SDEVIation
[, <soffset> [, <length> [, <roffset> [, <rlimit>]]]]

Returns compressed data for the specified trace data. The data is returned in the same units as the original trace and only works with the currently selected measurement. The command is used with a sub-opcode <n> since measurements usually return several types of trace data. See the following table for the sub-opcodes for the trace data names that are available in each measurement. For sub-opcodes that return scalar data use the **:CALCulate:DATA [n] ?** command above.

This command is used to compress or decimate a long trace to extract and return only the desired data. A typical example would be to acquire N frames of GSM data and return the mean power of the first burst in each frame. The command can also be used to identify the best curve fit for the data.

BLOCK or block data - returns all the data points from the region of the trace data that you specify. For example, it could be used to return the data points of an input signal over several timeslots, excluding the portions of the trace data that you do not want.

CFIT or curve fit - applies curve fitting routines to the data. <soffset> and <length> are required to define the data that you want. <roffset> is an optional parameter for the desired order of the

curve equation. The query will return the following values: the x-offset (in seconds) and the curve coefficients ((order + 1) values).

MAX, MEAN, MIN, RMS, SAMP, and SDEV return one data value for each specified region (or <length>) of trace data, for as many regions as possible until you run out of trace data (using <roffset> to specify regions). Or they return the number regions you specify (using <rlimit>) ignoring any data beyond that.

MAXimum - returns the maximum data point for the specified region(s) of trace data. For I/Q trace data, the maximum magnitude of the I/Q pairs is returned.

MEAN - returns the arithmetic mean of the data point values for the specified region(s) of trace data. For I/Q trace data, the mean of the magnitudes of the I/Q pairs is returned. Note: If the original trace data is in dB, this function returns the arithmetic mean of those log values, not log of the mean power, which is a more useful value.

MINimum - returns the minimum data point for the specified region(s) of trace data. For I/Q trace data, the minimum magnitude of the I/Q pairs is returned.

RMS - returns the arithmetic rms of the data point values for the specified region(s) of trace data. For I/Q trace data, the rms of the magnitudes of the I/Q pairs is returned. Note: This function is very useful for I/Q trace data. However, if the original trace data is in dB, this function returns the rms of the log values which is not usually needed.

Once you have the rms value for a region of I/Q trace data, you may want to calculate the mean power. You must convert this rms I/Q value (peak volts) to power in dB.

$$10 \times \log[10 \times (\text{rms value})^2]$$

SAMPle - returns the first data value for the specified region(s) of trace data. For I/Q trace data, the first I/Q pair is returned.

SDEViation - returns the arithmetic standard deviation for the data point values for the specified region(s) of trace data. For I/Q trace data, the standard deviation of the magnitudes of the I/Q pairs is returned.

Figure 5-1 Sample Trace Data - Constant Envelope

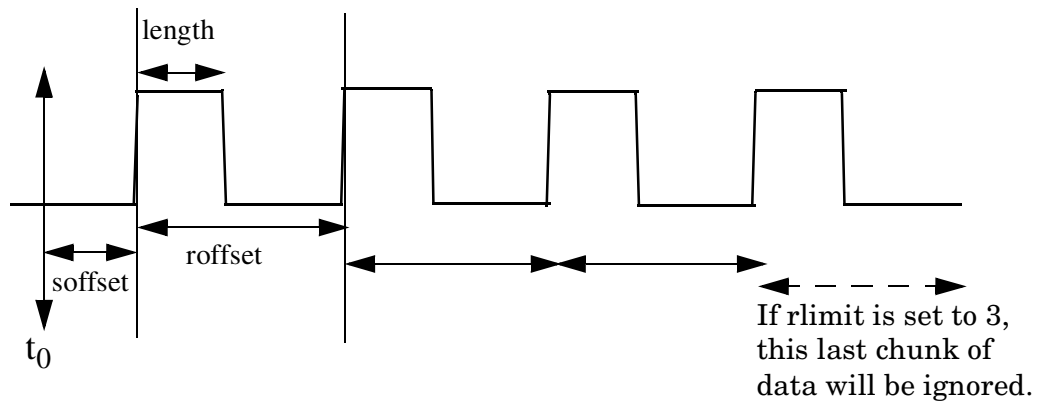
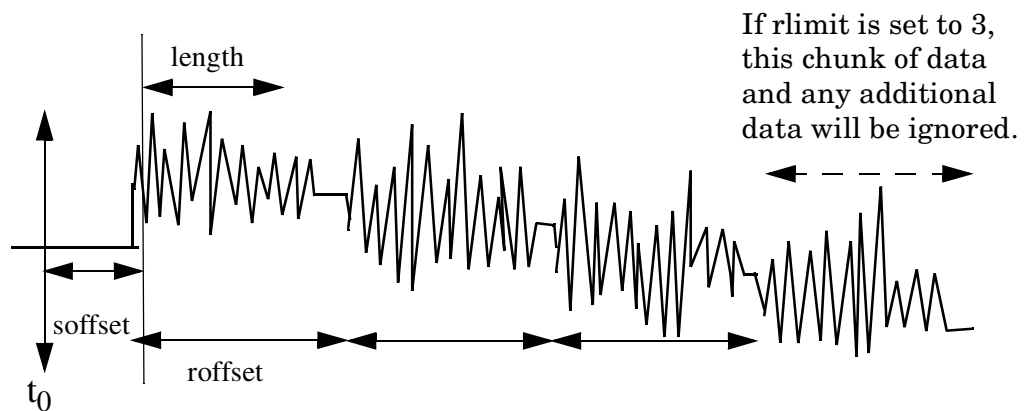

Figure 5-2 Sample Trace Data - Not Constant Envelope



<soffset> - start offset is an optional real number (in seconds). It specifies the amount of data at the beginning of the trace that will be ignored before the decimation process starts. It is the time from the start of the trace to the point where you want to start using the data. The default value is zero.

<length> - is an optional real number (in seconds). It defines how much data will be compressed into one value. This parameter has a default value equal to the current trace length.

<roffset> - repeat offset is an optional real number (in seconds). It defines the beginning of the next field of trace elements to be compressed. This is relative to the beginning of the previous field. This parameter has a default value equal to the <length> variable.

<rlimit> - repeat limit is an optional integer. It specifies the number of data items that you want returned. It will ignore any additional items beyond that number. You can use the Start offset and the Repeat limit to pick out exactly what part of the data you want to use. The default value is all the data.

Example: To query the mean power of a set of GSM bursts:

1. Set the waveform measurement sweep time to acquire at least one burst.
2. Set the triggers such that acquisition happens at a known position relative to a burst.
3. Then query the mean burst levels using,
CALC:DATA2:COMP? MEAN, 24e-6, 526e-6 (These parameter values correspond to GSM signals, where 526e-6 is the length of the burst in the slot and you just want 1 burst.)

NOTE For PSA there is a more detailed example in the “Improving the Speed of Your Measurements” section in the PSA Series *User’s and Programmer’s Reference*. There is also a sample program in the Programming Fundamentals chapter of that book, and a copy of it is on the documentation CD-ROM.

NOTE For E4406A there is a more detailed example in the “Improving the Speed of Your Measurements” section in the E4406A *Programmer’s Guide*. There is also a sample program in the Programming Fundamentals chapter of that book, and a copy of it is on the documentation CD-ROM.

Remarks: The optional parameters must be entered in the specified order. For example, if you want to specify <length>, you must also specify <soffset>.

This command uses the data in the format specified by FORMat:DATA, returning either binary or ASCII data.

History: For PSA:
 Added in revision A.02.00

For E4406A:
 Added in revision A.03.00
 Changed in revision A.05.00

Measurement	Available Traces	Markers Available?
ACP - adjacent channel power (Basic, cdmaOne, cdma2000, W-CDMA, iDEN (E4406A only), NADC, PDC modes)	no traces <i>(n=0)^a</i> for I/Q points	no markers
BER - bit error rate (iDEN mode, E4406A only)	no traces <i>(n=0)^a</i> for I/Q data	no markers

Measurement	Available Traces	Markers Available?
CDPower - code domain power (cdmaOne mode)	POWer ($n=2$) ^a TIMing ($n=3$) ^a PHASe ($n=4$) ^a ($n=0$) ^a for I/Q points	yes
CDPower - code domain power (cdma2000, W-CDMA, 1xEV-DO modes)	CDPower ($n=2$) ^a EVM ($n=5$) ^a MERRor ($n=6$) ^a PERRor ($n=7$) ^a SPOWer ($n=9$) ^a CPOWer ($n=10$) ^a ($n=0$) ^a for I/Q points	yes
CHPower - channel power (Basic, cdmaOne, cdma2000, W-CDMA, 1xEV-DO modes)	SPECTrum ($n=2$) ^a ($n=0$) ^a for I/Q points	no markers
CSPur - spurs close (cdmaOne mode)	SPECTrum ($n=2$) ^a ULIMit ($n=3$) ^a ($n=0$) ^a for I/Q points	yes
EEVM - EDGE error vector magnitude (EDGE mode)	EVMerror ($n=2$) ^a MERRor ($n=3$) ^a PERRor ($n=4$) ^a ($n=0$) ^a for I/Q points	yes
EORFspectr - EDGE output RF spectrum (EDGE mode)	RFEMod ($n=2$) ^a RFESwitching ($n=3$) ^a SPEMod ($n=4$) ^a LIMMod ($n=5$) ^a ($n=0$) ^a for I/Q points	yes, only for a single offset yes, only for multiple offsets

Measurement	Available Traces	Markers Available?
EPVTime - EDGE power versus time (EDGE mode)	RFENvelope ($n=2$) ^a UMASk ($n=3$) ^a LMASk ($n=4$) ^a ($n=0$) ^a for I/Q points	yes
ETSPur - EDGE transmit band spurs (EDGE mode)	SPECtrum ($n=2$) ^a ULIMit ($n=3$) ^a ($n=0$) ^a for I/Q points	yes
EVM - error vector magnitude (NADC, PDC modes)	EVM ($n=2$) ^a MERRor ($n=3$) ^a PERRor ($n=4$) ^a ($n=0$) ^a for I/Q points	yes
EVMQpsk - QPSK error vector magnitude (cdma2000, W-CDMA, 1xEV-DO modes)	EVM ($n=2$) ^a MERRor ($n=3$) ^a PERRor ($n=4$) ^a ($n=0$) ^a for I/Q points	yes
IM - intermodulation (cdma2000, W-CDMA, 1xEV-DO modes)	SPECtrum ($n=2$) ^a ($n=0$) ^a for I/Q points	yes
MCPower - multi-carrier power (W-CDMA mode)	no traces ($n=0$) ^a for I/Q points	no markers
OBW - occupied bandwidth (cdmaOne, cdma2000, iDEN (E4406A only), PDC, W-CDMA, 1xEV-DO modes)	no traces ($n=0$) ^a for I/Q points	no markers
ORFSpectrum - output RF spectrum (GSM, EDGE mode)	RFEMod ($n=2$) ^a RFESwitching ($n=3$) ^a SPEMod ($n=4$) ^a LIMMod ($n=5$) ^a ($n=0$) ^a for I/Q points	yes, only for a single offset yes, only for multiple offsets

Measurement	Available Traces	Markers Available?
PControl - power control (W-CDMA mode)	RFENvelope POWER	yes
PFError - phase and frequency error (GSM, EDGE mode)	PERRor ($n=2$) ^a PFERror ($n=3$) ^a RFENvelope ($n=4$) ^a ($n=0$) ^a for I/Q points	yes
PStatistic - power statistics CCDF (Basic, cdma2000, W-CDMA, 1xEV-DO modes)	MEASured ($n=2$) ^a GAUSSian ($n=3$) ^a REFerence ($n=4$) ^a ($n=0$) ^a for I/Q points	yes
PVTime - power versus time (GSM, EDGE, 1xEV-DO, Service (E4406A only) modes)	RFENvelope ($n=2$) ^a UMASk ($n=3$) ^a LMASk ($n=4$) ^a ($n=0$) ^a for I/Q points	yes
RHO - modulation quality (cdmaOne, cdma2000, W-CDMA, 1xEV-DO mode)	($n=0$) ^a for I/Q points EVM ($n=2$) ^a MERRor ($n=3$) ^a PERRor ($n=4$) ^a ($n=0$) ^a for I/Q points	yes
SEMask - spectrum emissions mask (cdma2000, W-CDMA, 1xEV-DO mode)	SPECTrum ($n=2$) ^a ($n=0$) ^a for I/Q points	yes
TSPur - transmit band spurs (GSM, EDGE mode)	SPECTrum ($n=2$) ^a ULIMit ($n=3$) ^a ($n=0$) ^a for I/Q points	yes
TXPower - transmit power (GSM, EDGE mode)	RFENvelope ($n=2$) ^a IQ ($n=8$) ^a ($n=0$) ^a for I/Q points	yes

Measurement	Available Traces	Markers Available?
SPECTrum - (frequency domain) (all modes)	RFENvelope ($n=2$) ^a for Service mode (E4406A only) IQ ($n=3$) ^a SPECTrum ($n=4$) ^a ASPECTrum ($n=7$) ^a ($n=0$) ^a for I/Q points	yes
WAVEform - (time domain) (all modes)	RFENvelope ($n=2$) ^a (also for Signal Envelope trace) IQ ($n=5$) ^a ($n=0$) ^a for I/Q points	yes

a. The n number indicates the sub-opcode that corresponds to this trace. Detailed descriptions of the trace data can be found in the MEASure subsystem documentation by looking up the sub-opcode for the appropriate measurement.

Calculate Peaks of Trace Data

```
:CALCulate:DATA<n>:PEAKs?  

<threshold>,<excursion>[,AMPLitude|FREQUENCY|TIME]
```

Returns a list of peaks for the designated trace data n for the currently selected measurement. The peaks must meet the requirements of the peak threshold and excursion values.

The command can only be used with specific $\langle n \rangle$ (sub-opcode) values, for measurement results that are trace, or scalar, data. See the table above for the appropriate sub-opcodes. Both real and complex traces can be searched, but complex traces are converted to magnitude in dBm. Sub-opcode $n=0$, is the raw trace data which cannot be searched for peaks. Sub-opcode $n=1$, is the scalar data which also cannot be searched for peaks.

Threshold - is the level below which trace data peaks are ignored

Excursion - To be defined as a peak, the signal must rise above the threshold by a minimum amplitude change (excursion). Excursion is measured from the lowest point above the threshold (of the rising edge of the peak), to the highest signal point that begins the falling edge. If a signal valley is higher than the threshold, then the

excursion is referenced to that valley, and a peak is only defined if the signal following that valley exceeds the excursion.

Amplitude - lists the peaks in order of descending amplitude, so the highest peak is listed first. This is the default peak order listing if the optional parameter is not specified.

Frequency - lists the peaks in order of occurrence, left to right across the x-axis

Time - lists the peaks in order of occurrence, left to right across the x-axis

Example: Select the spectrum measurement.

Use **CALC:DATA4:PEAK? -40,10,FREQ** to identify the peaks above -40 dBm, with excursions of at least 10 dB, in order of increasing frequency.

Query Results: Returns a list of floating-point numbers. The first value in the list is the number of peak points that follow. A peak point consists of two values: a peak amplitude followed by the its corresponding frequency (or time).

If no peaks are found the peak list will consist of only the number of peaks, (0).

The peak list is limited to 100 peaks. Peaks in excess of 100 are ignored.

Remarks: This command uses the data setting specified by the **FORMat:DATA** command and can return real 32-bit, real 64-bit, or ASCII data. The default data format is ASCII.

History: For E4406A:
Added in revision A.03.00 and later

CALCulate:MARKers Subsystem

Markers can be put on your displayed measurement data to supply information about specific points on the data. Some of the things that markers can be used to measure include: precise frequency at a point, minimum or maximum amplitude, and the difference in amplitude or frequency between two points.

When using the marker commands you must specify the measurement in the SCPI command. We recommend that you use the marker commands only on the current measurement. Many marker commands will return invalid results, when used on a measurement that is not current. (This is true for commands that do more than simply setting or querying an instrument parameter.) No error is reported for these invalid results.

You must make sure that the measurement is completed before trying to query the marker value. Using the MEASure or READ command, before the marker command, forces the measurement to complete before allowing the next command to be executed.

Each measurement has its own instrument state for marker parameters. Therefore, if you exit the measurement, the marker settings in each measurement are saved and are then recalled when you change back to that measurement.

Basic Mode - <measurement> key words

- ACPr - no markers (E4406A only)
- CHPower - no markers (E4406A only)
- PStatistic - markers available (E4406A only)
- SPECTrum - markers available
- WAVeform - markers available

Service Mode - <measurement> key words

- PVTime - no markers
- SPECTrum - markers available
- WAVeform - markers available

1xEV-DO Mode - <measurement> key words

- CDPower - markers available
- CHPower - no markers
- EVMQpsk - markers available
- IM - markers available
- OBW - no markers
- PStatistic - markers available
- PVTime - markers available
- RHO - markers available

- SEMask - markers available
- SPECTrum - markers available
- WAVeform - markers available

cdmaOne Mode - <measurement> key words

- ACPr - no markers
- CHPower - no markers
- CDPower - markers available
- CSPur - markers available
- RHO - markers available
- SPECTrum - markers available
- WAVeform - markers available

cdma2000 Mode - <measurement> key words

- ACP - no markers
- CDPower - markers available
- CHPower - no markers
- EVMQpsk - markers available
- IM - markers available
- OBW - no markers
- PStatistic - markers available
- RHO - markers available
- SEMask - markers available
- SPECTrum - markers available
- WAVeform - markers available

GSM (with EDGE) Mode - <measurement> key words

- EEVM - markers available
- EORFspectr - markers available
- EPVTime - no markers
- ETSPur - markers available
- ORFSpectrum - markers available
- PFERror - markers available
- PVTime - no markers
- SPECTrum - markers available
- TSPur - markers available
- TXPower - no markers
- WAVeform - markers available

GSM Mode - <measurement> key words

- ORFSpectrum - markers available
- PFERror - markers available
- PVTime - no markers
- SPECTrum - markers available
- TSPur - markers available
- TXPower - no markers
- WAVeform - markers available

iDEN Mode - <measurement> key words

- ACP - no markers
- BER - no markers
- OBW - no markers
- SPECTrum - markers available
- WAVeform - markers available

NADC Mode - <measurement> key words

- ACP - no markers
- EVM - markers available
- SPECTrum - markers available
- WAVeform - markers available

PDC Mode - <measurement> key words

- ACP - no markers
- EVM - markers available
- OBW - no markers
- SPECTrum - markers available
- WAVeform - markers available

W-CDMA Mode - <measurement> key words

- ACP - no markers
- CDPower - markers available
- CHPower - no markers
- EVMQpsk - markers available
- IM - markers available
- MCPower - no markers
- OBW - no markers
- PStatistic - markers available
- RHO - markers available
- SEMask - markers available
- SPECTrum - markers available
- WAVeform - markers available

Example:

Suppose you are using the Spectrum measurement in your measurement personality. To position marker 2 at the maximum peak value of the trace that marker 2 is currently on, the command is:

```
:CALCulate:SPECTrum:MARKer2:MAXimum
```

You must make sure that the measurement is completed before trying to query the marker value. Use the MEASure or READ command before using the marker command. This forces the measurement to complete before allowing the next command to be executed.

Markers All Off on All Traces

:CALCulate:<measurement>:MARKer:AOff

Turns off all markers on all the traces in the specified measurement.

Example: **CALC:SPEC:MARK:AOff**

Remarks: The keyword for the current measurement must be specified in the command. (Some examples include: SPECTrum, WAVeform)

Front Panel

Access: **Marker, More, Marker All Off**

Marker Function Result

:CALCulate:<measurement>:MARKer [1] | 2 | 3 | 4:FUNction:RESult?

Queries the result of the currently active marker function. The measurement must be completed before querying the marker. A particular measurement may not have all the types of markers available.

The marker must have already been assigned to a trace. Use **:CALCulate:<measurement>:MARKer [1] | 2 | 3 | 4:TRACe** to assign a marker to a particular trace.

Example: **CALC:SPEC:MARK:FUNC:RES?**

Remarks: The keyword for the current measurement must be specified in the command. (Some examples include: SPECTrum, WAVeform)

Front Panel

Access: **Marker, Marker Function**

Marker Peak (Maximum) Search

:CALCulate:<measurement>:MARKer [1] | 2 | 3 | 4:MAXimum

Places the selected marker on the highest point on the trace that is assigned to that particular marker number.

The marker must have already been assigned to a trace. Use **:CALCulate:<measurement>:MARKer [1] | 2 | 3 | 4:TRACe** to assign a marker to a particular trace.

Example: **CALC:SPEC:MARK1:MAX**

Remarks: The keyword for the current measurement must be specified in the command. (Some examples include: SPECTrum, WAVeform)

Front Panel

Access: **Search**

Marker Peak (Minimum) Search

:CALCulate:<measurement>:MARKer [1] | 2 | 3 | 4:MINimum

Places the selected marker on the lowest point on the trace that is assigned to that particular marker number.

The marker must have already been assigned to a trace. Use

:CALCulate:<measurement>:MARKer [1] | 2 | 3 | 4:TRACe to assign a marker to a particular trace.

Example: **CALC:SPEC:MARK2 MIN**

Remarks: The keyword for the current measurement must be specified in the command. (Some examples include: SPECTrum, WAVEform)

Marker Mode

E4406A (all modes):

PSA Series (Basic, cdmaOne, cdma2000, W-CDMA, GSM/EDGE, NADC, PDC modes):

**:CALCulate:<measurement>:MARKer [1] | 2 | 3 | 4:MODE
POSITION|DELTA**

ESA/PSA Series (Phase Noise mode only):

**:CALCulate:<measurement>:MARKer [1] | 2 | 3 | 4:MODE
POSITION|DELTA|RMSDegree|RMSRadian|RFM|RMSJitter|OFF**

:CALCulate:<measurement>:MARKer [1] | 2 | 3 | 4:MODE?

E4406A/PSA: Selects the type of marker to be a normal position-type marker or a delta marker. A specific measurement may not have both types of markers. For example, several measurements only have position markers

ESA/PSA Phase Noise Mode: Selects the type of marker to be a normal position-type marker, a delta marker or an RMS measurement marker.

The marker must have already been assigned to a trace. Use

:CALCulate:<measurement>:MARKer [1] | 2 | 3 | 4:TRACe to assign a marker to a particular trace.

Example: **CALC:SPEC:MARK:MODE DELTA**

Remarks: For the delta mode only markers 1 and 2 are valid.

The keyword for the current measurement must be

specified in the command. (Some examples include: SPECTrum, WAVeform)

Front Panel

Access: **Marker, Marker [Delta]**

Marker On/Off

```
:CALCulate:<measurement>:MARKer [1] | 2 | 3 | 4 [:STATe] OFF|ON|0|1
```

```
:CALCulate:<measurement>:MARKer [1] | 2 | 3 | 4 [:STATe] ?
```

Turns the selected marker on or off.

The marker must have already been assigned to a trace. Use `:CALCulate:<measurement>:MARKer [1] | 2 | 3 | 4:TRACe` to assign a marker to a particular trace.

Example: **CALC:SPEC:MARK2: on**

Remarks: The keyword for the current measurement must be specified in the command. (Some examples include: SPECTrum, AREFERENCE, WAVeform)

The WAVeform measurement only has two markers available.

Front Panel

Access: **Marker, Select then Marker Normal or Marker On Off**

Marker to Trace

```
:CALCulate:<measurement>:MARKer [1] | 2 | 3 | 4:TRACe <trace_name>
```

```
:CALCulate:<measurement>:MARKer [1] | 2 | 3 | 4:TRACe?
```

Assigns the specified marker to the designated trace. Not all types of measurement data can have markers assigned to them.

Example: With the WAVeform measurement selected, a valid command is **CALC:SPEC:MARK2:TRACe rfenvelope**.

Range: The names of valid traces are dependent upon the selected measurement. See the following table for the available trace names. The trace name assignment is independent of the marker number.

Remarks: The keyword for the current measurement must be specified in the command. (Some examples include: SPECTrum, WAVeform)

Front Panel

Access: **Marker, Marker Trace**

Measurement	Available Traces	Markers Available?
ACP - adjacent channel power (Basic, cdmaOne, cdma2000, W-CDMA, iDEN (E4406A only), NADC, PDC modes)	no traces $(n=0)^a$ for I/Q points	no markers
BER - bit error rate (iDEN mode, E4406A only)	no traces $(n=0)^a$ for I/Q data	no markers
CDPower - code domain power (cdmaOne mode)	POWer $(n=2)^a$ TIMing $(n=3)^a$ PHASe $(n=4)^a$ $(n=0)^a$ for I/Q points	yes
CDPower - code domain power (cdma2000, W-CDMA, 1xEV-DO modes)	CDPower $(n=2)^a$ EVM $(n=5)^a$ MERRor $(n=6)^a$ PERRor $(n=7)^a$ SPOWer $(n=9)^a$ CPOWer $(n=10)^a$ $(n=0)^a$ for I/Q points	yes
CHPower - channel power (Basic, cdmaOne, cdma2000, W-CDMA, 1xEV-DO modes)	SPECtrum $(n=2)^a$ $(n=0)^a$ for I/Q points	no markers
CSPur - spurs close (cdmaOne mode)	SPECtrum $(n=2)^a$ ULIMit $(n=3)^a$ $(n=0)^a$ for I/Q points	yes
EEVM - EDGE error vector magnitude (EDGE mode)	EVMerror $(n=2)^a$ MERRor $(n=3)^a$ PERRor $(n=4)^a$ $(n=0)^a$ for I/Q points	yes

Measurement	Available Traces	Markers Available?
EORFspectr - EDGE output RF spectrum (EDGE mode)	RFEMod ($n=2$) ^a RFESwitching ($n=3$) ^a SPEMod ($n=4$) ^a LIMMod ($n=5$) ^a ($n=0$) ^a for I/Q points	yes, only for a single offset yes, only for multiple offsets
EPVTime - EDGE power versus time (EDGE mode)	RFENvelope ($n=2$) ^a UMASk ($n=3$) ^a LMASk ($n=4$) ^a ($n=0$) ^a for I/Q points	yes
ETSPur - EDGE transmit band spurs (EDGE mode)	SPECTrum ($n=2$) ^a ULIMit ($n=3$) ^a ($n=0$) ^a for I/Q points	yes
EVM - error vector magnitude (NADC, PDC modes)	EVM ($n=2$) ^a MERRor ($n=3$) ^a PERRor ($n=4$) ^a ($n=0$) ^a for I/Q points	yes
EVMQpsk - QPSK error vector magnitude (cdma2000, W-CDMA, 1xEV-DO modes)	EVM ($n=2$) ^a MERRor ($n=3$) ^a PERRor ($n=4$) ^a ($n=0$) ^a for I/Q points	yes
IM - intermodulation (cdma2000, W-CDMA, 1xEV-DO modes)	SPECTrum ($n=2$) ^a ($n=0$) ^a for I/Q points	yes
MCPower - multi-carrier power (W-CDMA mode)	no traces ($n=0$) ^a for I/Q points	no markers
OBW - occupied bandwidth (cdmaOne, cdma2000, iDEN (E4406A only), PDC, W-CDMA, 1xEV-DO modes)	no traces ($n=0$) ^a for I/Q points	no markers

Measurement	Available Traces	Markers Available?
ORFSpectrum - output RF spectrum (GSM, EDGE mode)	RFEMod ($n=2$) ^a RFESwitching ($n=3$) ^a SPEMod ($n=4$) ^a LIMMod ($n=5$) ^a ($n=0$) ^a for I/Q points	yes, only for a single offset yes, only for multiple offsets
PFERror - phase and frequency error (GSM, EDGE mode)	PERRor ($n=2$) ^a PFERror ($n=3$) ^a RFENvelope ($n=4$) ^a ($n=0$) ^a for I/Q points	yes
PStatistic - power statistics CCDF (Basic, cdma2000, W-CDMA, 1xEV-DO modes)	MEASured ($n=2$) ^a GAUSSian ($n=3$) ^a REFerence ($n=4$) ^a ($n=0$) ^a for I/Q points	yes
PVTime - power versus time (GSM, EDGE, 1xEV-DO, Service (E4406A only) modes)	RFENvelope ($n=2$) ^a UMASk ($n=3$) ^a LMASk ($n=4$) ^a ($n=0$) ^a for I/Q points	yes
RHO - modulation quality (cdmaOne, cdma2000, W-CDMA, 1xEV-DO mode)	($n=0$) ^a for I/Q points EVM ($n=2$) ^a MERRor ($n=3$) ^a PERRor ($n=4$) ^a ($n=0$) ^a for I/Q points	yes
SEMask - spectrum emissions mask (cdma2000, W-CDMA, 1xEV-DO mode)	SPECtrum ($n=2$) ^a ($n=0$) ^a for I/Q points	yes
TSPur - transmit band spurs (GSM, EDGE mode)	SPECtrum ($n=2$) ^a ULIMit ($n=3$) ^a ($n=0$) ^a for I/Q points	yes

Measurement	Available Traces	Markers Available?
TXPower - transmit power (GSM, EDGE mode)	RFENvelope ($n=2$) ^a IQ ($n=8$) ^a ($n=0$) ^a for I/Q points	yes
SPECTrum - (frequency domain) (all modes)	RFENvelope ($n=2$) ^a for Service mode (E4406A only) IQ ($n=3$) ^a SPECTrum ($n=4$) ^a ASPECTrum ($n=7$) ^a ($n=0$) ^a for I/Q points	yes
WAVEform - (time domain) (all modes)	RFENvelope ($n=2$) ^a (also for Signal Envelope trace) IQ ($n=5$) ^a ($n=0$) ^a for I/Q points	yes

a. The n number indicates the sub-opcode that corresponds to this trace. Detailed descriptions of the trace data can be found in the MEASure subsystem documentation by looking up the sub-opcode for the appropriate measurement.

Marker X Value

:CALCulate:<measurement>:MARKer [1] | 2 | 3 | 4 :X <param>

:CALCulate:<measurement>:MARKer [1] | 2 | 3 | 4 :X?

Position the designated marker on its assigned trace at the specified X value. The parameter value is in X-axis units (which is often frequency or time).

The marker must have already been assigned to a trace. Use **:CALCulate:<measurement>:MARKer [1] | 2 | 3 | 4 :TRACe** to assign a marker to a particular trace.

The query returns the current X value of the designated marker. The measurement must be completed before querying the marker.

Example: **CALC:SPEC:MARK2:X 1.2e6 Hz**

Range: For Phase Noise mode: Graph Start Offset and Stop

Offset frequencies.

Default Unit: Matches the units of the trace on which the marker is positioned

Remarks: The keyword for the current measurement must be specified in the command. (Some examples include: LPLot, ACP, WAVEform)

Front Panel

Access: **Marker, <active marker>, RPG**

Marker X Position

:CALCulate:<measurement>:MARKer [1] | 2 | 3 | 4 :X:POSition <integer>

:CALCulate:<measurement>:MARKer [1] | 2 | 3 | 4 :X:POSition?

Position the designated marker on its assigned trace at the specified X position. A trace is composed of a variable number of measurement points. This number changes depending on the current measurement conditions. The current number of points must be identified before using this command to place the marker at a specific location.

The marker must have already been assigned to a trace. Use

:CALCulate:<measurement>:MARKer [1] | 2 | 3 | 4 :TRACe to assign a marker to a particular trace.

The query returns the current X position for the designated marker. The measurement must be completed before querying the marker.

Example: **CALC:SPEC:MARK:X:POS 500**

Range: 0 to a maximum of (3 to 920,000)

Remarks: The keyword for the current measurement must be specified in the command. (Some examples include: SPECTrum, WAVEform)

Front Panel

Access: **Marker, <active marker>, RPG**

Marker Readout Y Value

:CALCulate:<measurement>:MARKer [1] | 2 | 3 | 4 :Y?

Readout the current Y value for the designated marker on its assigned trace. The value is in the Y-axis units for the trace (which is often dBm).

The marker must have already been assigned to a trace. Use

:CALCulate:<measurement>:MARKer [1] | 2 | 3 | 4 :TRACe to assign a marker to a particular trace.

The measurement must be completed before querying the marker.

Example: **CALC:SPEC:MARK1:Y?**

Default Unit: Matches the units of the trace on which the marker is positioned

Remarks: The keyword for the current measurement must be specified in the command. (Some examples include: LPLot, ACP, WAVEform)

Occupied Bandwidth - Limits

Occupied Bandwidth—Frequency Band Limit

PDC, cdma2000, W-CDMA, 1xEV-DO mode

:CALCulate:OBW:LIMit:FBLimit <freq>

:CALCulate:OBW:LIMit:FBLimit?

iDEN mode (E4406A only)

:CALCulate:OBWidth:LIMit:FBLimit <freq>

:CALCulate:OBWidth:LIMit:FBLimit?

Set the frequency bandwidth limit in Hz.

Factory Preset: 32 kHz for PDC

20 kHz for iDEN (E4406A only)

1.48 MHz for cdma2000, 1xEV-DO

5 MHz for W-CDMA

Range: 10 kHz to 60 kHz for PDC, iDEN (E4406A only)

10 kHz to 10 MHz for cdma2000, W-CDMA, 1xEV-DO

Default Unit: Hz

Remarks: You must be in the iDEN (E4406A only), PDC, cdma2000, W-CDMA, or 1xEV-DO mode to use this command. Use INSTRument:SElect to set the mode.

History: For E4406A:
Version A.02.00 or later

Occupied Bandwidth—Limit Test

PDC, cdma2000, W-CDMA, 1xEV-DO mode

:CALCulate:OBW:LIMit[:TEST] OFF|ON|0|1

:CALCulate:OBW:LIMit[:TEST]?

iDEN mode (E4406A only)

:CALCulate:OBWidth:LIMit:STATe OFF|ON|0|1

:CALCulate:OBWidth:LIMit:STATe?

Turn the limit test function on or off.

Factory Preset: ON

Remarks: You must be in the iDEN (E4406A only), PDC, cdma2000, W-CDMA, or 1xEV-DO mode to use this

command. Use INSTRument:SElect to set the mode.

History:

For E4406A:

Version A.02.00 or later

Power Statistic CCDF—Store Reference

```
:CALCulate:PStAtistic:StORe:REFEreNce ON|1
```

Store the currently measured trace as the user-defined reference trace. No query command is available.

Remarks: You must be in the cdma2000, W-CDMA, or 1xEV-DO mode to use this command. Use INSTRument:SELEct to set the mode.

Modulation Accuracy - Limits

Modulation Accuracy (Rho)—Active Set Threshold

`:CALCulate:RHO:ASET:THReshold <numeric>`

`:CALCulate:RHO:ASET:THReshold?`

Set the threshold level for the active channel identification function.

Factory Preset: 0.0 dBm

Range: -100.0 to 0.0 dB

Remarks: You must be in the 1xEV-DO mode to use this command. Use INSTRument:SElect to set the mode.

Modulation Accuracy (Rho)—Active Set Threshold Mode

`:CALCulate:RHO:ASET:THReshold:AUTO OFF|ON|0|1`

`:CALCulate:RHO:ASET:THReshold:AUTO?`

Turn the automatic mode On or Off, for the active channel identification function.

OFF – The active channel identification for each code channel is determined by a value set by `CALCulate:RHO:ASET:THReshold`.

ON – The active channels are determined automatically by the internal algorithm.

Factory Preset: ON

Remarks: You must be in W-CDMA, cdma2000, or 1xEV-DO mode to use this command. Use INSTRument:SElect to set the mode.

Modulation Accuracy (Rho)—Rho Result I/Q Offset

`:CALCulate:RHO:IQOffset:INCLude OFF|ON|0|1`

`:CALCulate:RHO:IQOffset:INCLude?`

Turn the automatic mode On or Off, for the I/Q origin offset function.

OFF – The measurement results for EVM and Rho do not take into account the I/Q origin offset.

ON – The measurement results for EVM and Rho take into account the I/Q origin offset.

Factory Preset: ON

Remarks: You must be in the 1xEV-DO mode to use this

command. Use INSTRument:SElect to set the mode.

Modulation Accuracy (Rho)—Min Data Active Power

`:CALCulate:RHO:LIMit:DATA[:ACTive] [:LOWer] <float>`

`:CALCulate:RHO:LIMit:DATA[:ACTive] [:LOWer]?`

Specify the DATA Active Power minimum limit value in dB.

Factory Preset: -15.55 dB

Range: -100.0 to
`:CALCulate:RHO:LIMit:DATA[ACTive] [:UPPer] dB`

Remarks: You must be in the 1xEV-DO mode to use this command. Use INSTRument:SElect to set the mode.

Modulation Accuracy (Rho)—Max Data Active Power

`:CALCulate:RHO:LIMit:DATA[:ACTive] [:UPPer] <float>`

`:CALCulate:RHO:LIMit:DATA[:ACTive] [:UPPer]?`

Specify the DATA Active Power maximum limit value in dB.

Factory Preset: -14.56 dB

Range: -100.0 to 0.0 dB

Remarks: You must be in the 1xEV-DO mode to use this command. Use INSTRument:SElect to set the mode.

Modulation Accuracy (Rho)—Frequency Error Limit

`:CALCulate:RHO:LIMit:FREQuency <numeric>`

`:CALCulate:RHO:LIMit:FREQuency?`

Specify a limit value in ppm for the frequency error test.

Factory Preset: 0.05 ppm

Range: 0.0 to 1.0 ppm

Unit: ppm

Remarks: You must be in the 1xEV-DO mode to use this command. Use INSTRument:SElect to set the mode.

Front Panel

Access: **Meas Setup, More, Limits...**

Modulation Accuracy (Rho)—Max MAC Inactive Power

`:CALCulate:RHO:LIMit:MAC:INACTive[:UPPer] <float>`

`:CALCulate:RHO:LIMit:MAC:INACTive[:UPPer] ?`

Specify the MAC inactive power limit value in dB.

Factory Preset: -27.00 dB

Range: -100.0 to 0 dB

Unit: ppm

Remarks: You must be in the 1xEV-DO mode to use this command. Use INSTRument:SElect to set the mode.

Front Panel

Access: **Meas Setup, More, Limits...**

Modulation Accuracy (Rho)—Peak EVM Limit (BTS)

`:CALCulate:RHO:LIMit:PEAK[:BTS] <float>`

`:CALCulate:RHO:LIMit:PEAK[:BTS] ?`

Specify a limit value in percent for the peak EVM test.

Factory Preset: 100.0%

Range: 0.0 to 200.0%

Remarks: You must be in the cdma2000, W-CDMA, or 1xEV-DO mode to use this command. Use INSTRument:SElect to set the mode.

Modulation Accuracy (Rho)—Phase Error Limit

`:CALCulate:RHO:LIMit:PHASe <float>`

`:CALCulate:RHO:LIMit:PHASe ?`

Specify a limit value in radian for the phase error test.

Factory Preset: 0.05 rad

Range: 0.00 to 3.00 rad

Remarks: You must be in the cdma2000 or 1xEV-DO mode to use this command. Use INSTRument:SElect to set the mode.

Modulation Accuracy (Rho)—Pilot Time Offset Limit

`:CALCulate:RHO:LIMit:POFFset <float>`

`:CALCulate:RHO:LIMit:POFFset?`

Specify a limit value for the Pilot time offset test from the external trigger.

Factory Preset: 10.0 μ s

Range: 0.0 to 100.0 μ s

Remarks: You must be in the 1xEV-DO mode to use this command. Use INSTRument:SElect to set the mode.

Modulation Accuracy (Rho)—Rho Limit (BTS)

`:CALCulate:RHO:LIMit:RHO[:BTS] <float>`

`:CALCulate:RHO:LIMit:RHO[:BTS]?`

Specify a limit value for the Rho test.

Factory Preset: 0.5

Range: 0 to 1.0

Remarks: You must be in the cdma2000, W-CDMA, or 1xEV-DO mode to use this command. Use INSTRument:SElect to set the mode.

Modulation Accuracy (Rho)—RMS EVM Limit (BTS)

`:CALCulate:RHO:LIMit:RMS[:BTS] <float>`

`:CALCulate:RHO:LIMit:RMS[:BTS]?`

Specify a limit value in percent for the rms EVM test.

Factory Preset: 17.5%

Range: 0.0 to 100.0%

Remarks: You must be in the cdma2000, W-CDMA, or 1xEV-DO mode to use this command. Use INSTRument:SElect to set the mode.

Modulation Accuracy (Rho)—Time Offset Limit

`:CALCulate:RHO:LIMit:TIMing <float>`

`:CALCulate:RHO:LIMit:TIMing?`

Specify a limit value in second for the time offset test.

Factory Preset: 0.00000005 s (50 ns)

Range: 0 to 0.0000005 s (0 to 500 ns)

Remarks: You must be in the cdma2000 or 1xEV-DO mode to use this command. Use INSTRument:SElect to set the mode.

Modulation Accuracy (Rho)—Channel Type

:CALCulate:RHO:TYPE ALL|DATA|MAC|PILot|PREamble

:CALCulate:RHO:TYPE?

Select one of the following channel types to be used measurements.

ALL – measure Rho Overall-1 and Rho Overall-2 as specified in 3GPP2 TSG-4.1 Recommended Minimum Performance Standard for cdma2000 High Rate Data Packet Access Network, 11.4.2. Waveform Quality Measurement section.

DATA – measure the data channel.

MAC – measure the medium access control (MAC) channel.

PILot – measure the Pilot channel.

PREamble – measure the preamble data chips overlaid on the data channel.

Factory Preset: PILot

Remarks: You must be in the 1xEV-DO mode to use this command. Use INSTRument:SElect to set the mode.

Modulation Accuracy (Rho)—Data Type

:CALCulate:RHO:TYPE:DATA OPSK|QAM|QPSK

:CALCulate:RHO:TYPE:DATA?

Select one of the following data types to be used for encoding.

OPSK – Eight phase shift keying (8PSK)

QAM – Sixteen quadrature amplitude modulation (16QAM)

QPSK – Quadrature phase shift keying

Factory Preset: QPSK

Remarks: You must be in the 1xEV-DO mode to use this command. Use INSTRument:SElect to set the mode.

Terminal Modulation Accuracy - Limits

Terminal Modulation Accuracy (Rho)—Active Set Threshold

:CALCulate:TRHO:ASET:THReshold <numeric>

:CALCulate:TRHO:ASET:THReshold?

Set the threshold level for the active channel identification function.

Factory Preset: 0.0 dB

Range: -100.0 to 0.0 dB

Remarks: You must be in the 1xEV-DO mode to use this command. Use INSTRument:SElect to set the mode.

Terminal Modulation Accuracy (Rho)—Active Set Threshold Mode

:CALCulate:TRHO:ASET:THReshold:AUTO OFF | ON | 0 | 1

:CALCulate:TRHO:ASET:THReshold:AUTO?

Turn the automatic mode On or Off, for the active channel identification function.

OFF – The active channel identification for each code channel is determined by a value set by CALCulate:RHO:ASET:THReshold.

ON – The active channels are determined automatically by the internal algorithm.

Factory Preset: ON

Remarks: You must be in 1xEV-DO mode to use this command. Use INSTRument:SElect to set the mode.

Terminal Modulation Accuracy (Rho)—I/Q Offset Include

:CALCulate:TRHO:IQOFfset:INCLude OFF | ON | 0 | 1

:CALCulate:TRHO:IQOFfset:INCLude?

Turn the automatic mode On or Off, for the I/Q origin offset function.

OFF – The measurement results for EVM and Rho do not include the I/Q origin offset.

ON – The measurement results for EVM and Rho include the I/Q origin offset.

Factory Preset: ON

Remarks: You must be in the 1xEV-DO mode to use this command. Use INSTRUMENT:SElect to set the mode.

Terminal Modulation Accuracy (Rho)—Active Code Domain Power Tolerance

:CALCulate:TRHO:LIMit:ACDPower <float>

:CALCulate:TRHO:LIMit:ACDPower?

Set the Active Code Domain Power tolerance limit in dB.

Factory Preset: 0.25 dB

Range: 0.0 to 3.0 dB

Remarks: You must be in the 1xEV-DO mode to use this command. Use INSTRUMENT:SElect to set the mode.

Terminal Modulation Accuracy (Rho)—ACK Channel Power Gain

:CALCulate:TRHO:LIMit:ACK:GAIN <float>

:CALCulate:TRHO:LIMit:ACK:GAIN?

Set the ACK channel power gain in dB.

Factory Preset: 3.0 dB

Range: -10.0 to 10.0 dB

Remarks: You must be in the 1xEV-DO mode to use this command. Use INSTRUMENT:SElect to set the mode.

Terminal Modulation Accuracy (Rho)—Peak Code Domain Error Limit

:CALCulate:TRHO:LIMit:CDERror <float>

:CALCulate:TRHO:LIMit:CDERror?

Set the Peak Code Domain Error limit in dB.

Factory Preset: -40.0 dB

Range: -100.0 to 0.0 dB

Remarks: You must be in the 1xEV-DO mode to use this command. Use INSTRUMENT:SElect to set the mode.

Terminal Modulation Accuracy (Rho)—Data Channel Power Gain

:CALCulate:TRHO:LIMit:DATA:GAIN <float>

:CALCulate:TRHO:LIMit:DATA:GAIN?

Set the Data channel power gain in dB.

Factory Preset: 3.75 dB

Range: -10.0 to 10.0 dB

Remarks: You must be in the 1xEV-DO mode to use this command. Use INSTRUMENT:SElect to set the mode.

Terminal Modulation Accuracy (Rho)—DRC Channel Power Gain

:CALCulate:TRHO:LIMit:DRC:GAIN <float>

:CALCulate:TRHO:LIMit:DRC:GAIN?

Set the DRC channel power gain in dB.

Factory Preset: 3.0 dB

Range: -10.0 to 10.0 dB

Remarks: You must be in the 1xEV-DO mode to use this command. Use INSTRUMENT:SElect to set the mode.

Terminal Modulation Accuracy (Rho)—Frequency Error Limit

:CALCulate:TRHO:LIMit:FERRor <float>

:CALCulate:TRHO:LIMit:FERRor?

Set the Frequency Error limit in Hz.

Factory Preset: 300.0 Hz

Range: 0.0 to 10.0 kHz

Remarks: You must be in the 1xEV-DO mode to use this command. Use INSTRUMENT:SElect to set the mode.

Terminal Modulation Accuracy (Rho)—Inactive Channel CDP

:CALCulate:TRHO:LIMit:ICDPower <float>

:CALCulate:TRHO:LIMit:ICDPower?

Specify the Max inactive code domain power limit value in dBc.

Factory Preset: -23.00 dBc

Range: -100.0 to 0 dBc

Remarks: You must be in the 1xEV-DO mode to use this command. Use INSTRument:SElect to set the mode.

Front Panel

Access: Meas Setup, More, Limits...

Terminal Modulation Accuracy (Rho)—Peak EVM Limit

:CALCulate:TRHO:LIMit:PEAK <float>

:CALCulate:TRHO:LIMit:PEAK?

Specify a limit value in percent for the peak EVM test.

Factory Preset: 100.0%

Range: 0.0 to 200.0%

Resolution: 0.1%

Step: 0.1%

Remarks: You must be in the 1xEV-DO mode to use this command. Use INSTRument:SElect to set the mode.

Terminal Modulation Accuracy (Rho)—Pilot Time Offset Limit

:CALCulate:TRHO:LIMit:POFFset <float>

:CALCulate:TRHO:LIMit:POFFset?

Specify a limit value for the Pilot time offset test from the external trigger.

Factory Preset: 1.0 μ s

Range: 0.0 to 100.0 ms

Remarks: You must be in the 1xEV-DO mode to use this command. Use INSTRument:SElect to set the mode.

Terminal Modulation Accuracy (Rho)—Rho Limit

:CALCulate:TRHO:LIMit:RHO <float>

:CALCulate:TRHO:LIMit:RHO?

Specify a limit value for the Rho test.

Factory Preset: 0.5

Range: 0 to 1.0

Remarks: You must be in the 1xEV-DO mode to use this command. Use INSTRument:SElect to set the mode.

Terminal Modulation Accuracy (Rho)—RMS EVM Limit

:CALCulate:TRHO:LIMit:RMS <float>

:CALCulate:TRHO:LIMit:RMS?

Specify a limit value in percent for the rms EVM test.

Factory Preset: 50.0%

Range: 0.0 to 100.0%

Remarks: You must be in the 1xEV-DO mode to use this command. Use INSTRument:SElect to set the mode.

Terminal Modulation Accuracy (Rho)—RRI Relative Power Limit

:CALCulate:TRHO:LIMit:RRI <float>

:CALCulate:TRHO:LIMit:RRI?

Specify a tolerance limit for the RRI Power (ratio to Pilot) value in dB.

Factory Preset: 0.25 dB

Range: 0.00 to 3.00

Remarks: You must be in the 1xEV-DO mode to use this command. Use INSTRument:SElect to set the mode.

CONFigure Subsystem

The CONFigure commands are used with several other commands to control the measurement process. The full set of commands are described in the section “MEASure Group of Commands” on page 339.

Selecting measurements with the CONFigure/FETCh/MEASure/READ commands sets the instrument state to the defaults for that measurement and to make a single measurement. Other commands are available for each measurement to allow you to change: settings, view, limits, etc. Refer to:

```
SENSE:<measurement>, SENSE:CHANnel, SENSE:CORRection,  
SENSE:DEFaults, SENSE:DEVIation, SENSE:FREQUency,  
SENSE:PACKet, SENSE:POWer, SENSE:RADio, SENSE:SYNC  
CALCulate:<measurement>, CALCulate:CLIMits  
DISPlay:<measurement>  
TRIGger
```

The INITiate[:IMMediate] or INITiate:REStart commands will initiate the taking of measurement data without resetting any of the measurement settings that you have changed from their defaults.

Configure the Selected Measurement

```
:CONFigure:<measurement>
```

A CONFigure command must specify the desired measurement. It will set the instrument settings for that measurement's standard defaults, but should not initiate the taking of data. The available measurements are described in the MEASure subsystem.

NOTE

If CONFigure initiates the taking of data, the data should be ignored. Other SCPI commands can be processed immediately after sending CONFigure. You do not need to wait for the CONF command to complete this 'false' data acquisition.

Configure Query

```
:CONFigure?
```

The CONFigure query returns the name of the current measurement.

DISPlay Subsystem

The DISPlay controls the selection and presentation of textual, graphical, and TRACe information. Within a DISPlay, information may be separated into individual WINDows.

Code Domain - View Selection

```
:DISPlay:CDPower:VIEW PGRaph|IQPGraph
```

```
:DISPlay:CDPower:VIEW?
```

Select one of the code domain measurement result views as follows:

PGRaph (Power Graph & Metrics) - provides a combination view of the code domain power graph and the summary data.

IQPGraph (I/Q Polar & Power Graph) - provides a combination view of the code domain power graph, symbol I/Q polar graph, and chip power vs. time graph.

Factory Preset: PGRaph (Power Graph & Metrics)

Remarks: You must be in the 1xEV-DO mode to use this command. Use INSTRument:SElect to set the mode.

Front Panel

Access: **Code Domain, View/Trace**

Select Display Format

```
:DISPlay:FORMat:TILE
```

Selects the viewing format that displays multiple windows of the current measurement data simultaneously. Use DISP:FORM:ZOOM to return the display to a single window.

Remarks: For PSA you must be in the Basic, cdmaOne,cdma2000, 1xEV-DO, W-CDMA, GSM (w/EDGE), NADC, or PDC mode to use this command. Use INSTRument:SElect to set the mode

Front Panel

Access: **Zoom** (toggles between Tile and Zoom)

Select Display Format

:DISPlay:FORMat:ZOOM

Selects the viewing format that displays only one window of the current measurement data (the current active window). Use DISP:FORM:TILE to return the display to multiple windows.

Remarks: For PSA you must be in the Basic, cdmaOne,cdma2000, 1xEV-DO, W-CDMA, GSM (w/EDGE), NADC, or PDC mode to use this command. Use INSTRument:SElect to set the mode

Front Panel

Access: **Zoom** (toggles between Tile and Zoom)

PVT - Limit Mask Display

:DISPlay:PVTime:LIMit:MASK OFF|ON|0|1

:DISPlay:PVTime:LIMit:MASK?

Turns on/off the display function of the limit mask lines. It also controls the limit checking function.

See also [:SENS]:PVT:LIM:MASK.

Factory Preset: ON

Remarks: You must be in GSM, EDGE, 1xEV-DO or W-CDMA mode to use this command. Use INSTRument:SElect to set the mode.

Front Panel

Access: **Power vs Time, Display**

PVT - Burst Search Threshold Line

:DISPlay:PVTime:BURSt:STHreshold OFF|ON|0|1

:DISPlay:PVTime:BURSt:STHreshold?

Turn on or off the display function of the burst search threshold line.

ON - display the burst search threshold line.

OFF - disable to display the burst search threshold line.

Factory Preset: ON

Remarks: You must be in the 1xEV-DO mode to use this command. Use INSTRument:SElect to set the mode.

Front Panel
Access: **Power vs Time, Display**

PVT - View Selection

:DISPlay:PVTime:VIEW ALL|BOTH|A|B|C|D|E

:DISPlay:PVTime:VIEW?

Select one of the power versus time measurement result views as follows:

ALL - displays the whole burst waveform throughout the all regions.

BOTH - displays both the rising and falling edges expanded in the horizontal scale.

A - display only the A region in the full horizontal scale.

B - display only the B region in the full horizontal scale.

C - display only the C region in the full horizontal scale.

D - display only the D region in the full horizontal scale.

E - display only the E region in the full horizontal scale.

Factory Preset: ALL

Remarks: You must be in the 1xEV-DO or W-CDMA mode to use this command. Use INSTRument:SElect to set the mode.

Front Panel
Access: **Power vs Time, View/Trace**

Modulation Accuracy (Rho) - View Selection

1xEV-DO (Forward link)

:DISPlay:RHO:VIEW ERRor|POLar|QUAD|TABLE|TPHase

1xEV-DO (Reverse link)

:DISPlay:RHO:VIEW ERRor|POLar|TABLE

CDMA2000

:DISPlay:RHO:VIEW ERRor|POLar

W-CDMA

:DISPlay:RHO:VIEW ERRor|POLar|PGRaph|TABLE

:DISPlay:RHO:VIEW?

Select one of the modulation accuracy (rho) measurement result views as follows:

ERRor (IQ Error: Quad View) - provides a combination view of the EVM vs. symbol, phase error vs. symbol, magnitude error vs. symbol graphs, and the summary data for each channel type specified.

POLar (IQ Measured Polar Graph) - provides a combination view of the I/Q measured polar constellation graph and the summary data for each channel type specified.

QUAD (IQ Measured: Quad-view) - provides a combination view of an I/Q power vs. chip, I/Q vector absolute power vs. chip, I/Q polar graphs, and the summary data for each channel type specified.

PGRaph (Code Domain Power) - provides a combination view of Code Domain Power Graph, I/Q measured polar constellation and Active Channel Table.

TABLE (Result Metrics) - provides a measurement result on Rho, EVM, and other metrics of each channel type specified in tabular form.

TPHase (Power Timing and Phase) - provides a measurement result on power levels, timing, phase, and code domain errors in tabular form for each active code.

Factory Preset: POLar

Remarks: You must be in the 1xEV-DO, W-CDMA, or cdma2000 mode to use this command. Use INSTRUMENT:SElect to set the mode.

Front Panel

Access: **Mod Accuracy, View/Trace**

Spectrum - Y-Axis Scale/Div

```
:DISPlay:SPECTrum [n] :WINDow [m] :TRACe:Y [:SCALe] :PDIVision  
<power>
```

```
:DISPlay:SPECTrum [n] :WINDow [m] :TRACe:Y [:SCALe] :PDIVision?
```

Sets the amplitude reference level for the y-axis.

n – selects the view, the default is Spectrum.

m – selects the window within the view. The default is 1.

— n=1, m=1 Spectrum

— n=1, m=2 I/Q Waveform

— n=1, m=2 I and Q Waveform (Basic, W-CDMA, cdma2000)

- n=1, m=3 numeric data (Service mode, E4406A only)
- n=1, m=4 RF envelope (Service mode, E4406A only)
- n=2, m=1 I Waveform (Option B7C, E4406A only)
- n=2, m=2 Q Waveform (Option B7C, E4406A only)
- n=3, m=1 I/Q Polar (Basic, W-CDMA, cdma2000)
- n=4, m=1 Linear Spectrum (Basic, W-CDMA, cdma2000)

Factory Preset: 10 dB per division, for Spectrum

100 mV per division, for I/Q Waveform

Range: 0.1 dB to 20 dB per division, for Spectrum

1 nV to 20 V per division, for I/Q Waveform

Default Unit: 10 dB per division, for Spectrum

Remarks: May affect input attenuator setting.

For E4406A to use this command, the appropriate mode should be selected with INSTRUMENT:SElect.

For PSA you must be in Basic, cdmaOne, cdma2000, 1xEV-DO, W-CDMA GSM w/EDGE, NADC, or PDC mode. Set the mode with INSTRUMENT:SElect.

Front Panel

Access: When in Spectrum measurement: **Amplitude Y Scale, Scale/Div.**

History: For PSA:
 Added revision A.02.00

For E4406A:
 Modified revision A.05.00

Spectrum - Y-Axis Reference Level

```
:DISPlay:SPECTrum[n]:WINDow[m]:TRACe:Y[:SCALE]:RLEVEL
<power>
```

```
:DISPlay:SPECTrum[n]:WINDow[m]:TRACe:Y[:SCALE]:RLEVEL?
```

Sets the amplitude reference level for the y-axis.

n, selects the view, the default is RF envelope.

- n=1, m=1 Spectrum
- n=1, m=2 I/Q Waveform
- n=1, m=2 I and Q Waveform (Basic, W-CDMA, cdma2000)

- n=1, m=3 numeric data (Service mode, E4406A only)
 - n=1, m=4 RF envelope (Service mode, E4406A only)
 - n=2, m=1 I Waveform (Option B7C, E4406A only)
 - n=2, m=2 Q Waveform (Option B7C, E4406A only)
 - n=3, m=1 I/Q Polar (Basic, W-CDMA, cdma2000)
 - n=4, m=1 Linear Spectrum (Basic, W-CDMA, cdma2000)
- m – selects the window within the view. The default is 1.

Factory Preset: 0 dBm, for Spectrum

Range: –250 to 250 dBm, for Spectrum

Default Unit: dBm, for Spectrum

Remarks: May affect input attenuator setting.

For E4406A to use this command, the appropriate mode should be selected with INSTRUMENT:SElect.

For PSA you must be in Basic, cdmaOne, cdma2000, 1xEV-DO, W-CDMA GSM w/EDGE, NADC, or PDC mode. Set the mode with INSTRUMENT:SElect.

Front Panel

Access: When in Spectrum measurement: **Amplitude Y Scale, Ref Level**

History: For PSA:
Added revision A.02.00
For E4406A:
Modified revision A.05.00

Terminal Code Domain Measurement - View Selection

```
:DISPlay:TCDPower:VIEW PGRaph|QUAD|SEVM|DBITs
```

```
:DISPlay:TCDPower:VIEW?
```

Select one of the terminal code domain measurement result views as follows:

PGRaph - provides a combination view of the code domain power graph and the summary data.

QUAD - provides a combination view of graphics for code domain power, symbol power, I/Q symbol polar vector, and the summary data for the specified code channel.

SEVM - provides a combination view of the magnitude error, phase error, EVM graphs, and summary data for the specified code

channel.

DBITs - provides a combination view of the graphics for the code domain power and symbol power, and the I/Q demodulated bit stream data for symbol power slots selected by measurement interval and measurement offset.

Factory Preset: PGRaph

Remarks: You must be in the 1xEV-DO mode to use this command. Use INSTRument:SElect to set the mode.

Front Panel

Access: **Mod Accuracy, View/Trace**

Turn a Trace Display On/Off

:DISPlay:TRACe [n] [:STATe] OFF|ON|0|1

:DISPlay:TRACe [n] [:STATe] ?

Controls whether the specified trace is visible or not.

n is a sub-opcode that is valid for the current measurement. See the [“MEASure Group of Commands” on page 339](#) for more information about sub-opcodes.

Factory Preset: On

Range: The valid traces and their sub-opcodes are dependent upon the selected measurement. See the following table.

The trace name assignment is independent of the window number.

Remarks: For E4406A to use this command, the appropriate mode should be selected with INSTRument:SElect.

Remarks: For PSA you must be in the Basic, cdmaOne,cdma2000, 1xEV-DO, W-CDMA, GSM (w/EDGE), NADC, or PDC mode to use this command. Use INSTRument:SElect to set the mode

Front Panel

Access: **Display, Display Traces**

Measurement	Available Traces	Markers Available?
ACP - adjacent channel power (Basic, cdmaOne, cdma2000, W-CDMA, iDEN (E4406A only), NADC, PDC modes)	no traces $(n=0)^a$ for I/Q points	no markers
BER - bit error rate (iDEN mode, E4406A only)	no traces $(n=0)^a$ for I/Q data	no markers
CDPower - code domain power (cdmaOne mode)	POWer $(n=2)^a$ TIMing $(n=3)^a$ PHASe $(n=4)^a$ $(n=0)^a$ for I/Q points	yes
CDPower - code domain power (cdma2000, 1xEV-DO, W-CDMA modes)	$(n=0)^a$ for I/Q raw data CDPower $(n=2)^a$ EVM $(n=5)^a$ MERRor $(n=6)^a$ PERRor $(n=7)^a$ SPOWer $(n=9)^a$ CPOWer $(n=10)^a$	yes
CHPower - channel power (Basic, cdmaOne, cdma2000, 1xEV-DO, W-CDMA modes)	SPECtrum $(n=2)^a$ $(n=0)^a$ for I/Q raw data	no markers
CSPur - spurs close (cdmaOne mode)	SPECtrum $(n=2)^a$ ULIMit $(n=3)^a$ $(n=0)^a$ for I/Q points	yes
EEVM - EDGE error vector magnitude (EDGE mode)	EVMerror $(n=2)^a$ MERRor $(n=3)^a$ PERRor $(n=4)^a$ $(n=0)^a$ for I/Q points	yes

Measurement	Available Traces	Markers Available?
EORFspectr - EDGE output RF spectrum (EDGE mode)	RFEMod ($n=2$) ^a RFESwitching ($n=3$) ^a SPEMod ($n=4$) ^a LIMMod ($n=5$) ^a ($n=0$) ^a for I/Q points	yes, only for a single offset yes, only for multiple offsets
EPVTime - EDGE power versus time (EDGE mode)	RFENvelope ($n=2$) ^a UMASk ($n=3$) ^a LMASk ($n=4$) ^a ($n=0$) ^a for I/Q points	yes
ETSPur - EDGE transmit band spurs (EDGE mode)	SPECTrum ($n=2$) ^a ULIMit ($n=3$) ^a ($n=0$) ^a for I/Q points	yes
EVM - error vector magnitude (NADC, PDC modes)	EVM ($n=2$) ^a MERRor ($n=3$) ^a PERRor ($n=4$) ^a ($n=0$) ^a for I/Q points	yes
EVMQpsk - QPSK error vector magnitude (cdma2000, 1xEV-DO, W-CDMA modes)	EVM ($n=2$) ^a MERRor ($n=3$) ^a PERRor ($n=4$) ^a ($n=0$) ^a for I/Q raw data	yes
IM - intermodulation (cdma2000, 1xEV-DO, W-CDMA modes)	SPECTrum ($n=2$) ^a ($n=0$) ^a for I/Q raw data	yes
MCPower - multi-carrier power (W-CDMA mode)	no traces ($n=0$) ^a for I/Q points	no markers
OBW - occupied bandwidth (cdmaOne, cdma2000, 1xEV-DO, iDEN (E4406A only), PDC, W-CDMA modes)	no traces ($n=0$) ^a for I/Q raw data	no markers

Measurement	Available Traces	Markers Available?
ORFSpectrum - output RF spectrum (GSM, EDGE mode)	RFEMod ($n=2$) ^a RFESwitching ($n=3$) ^a SPEMod ($n=4$) ^a LIMMod ($n=5$) ^a ($n=0$) ^a for I/Q points	yes, only for a single offset yes, only for multiple offsets
PFERror - phase and frequency error (GSM, EDGE mode)	PERRor ($n=2$) ^a PFERror ($n=3$) ^a RFENvelope ($n=4$) ^a ($n=0$) ^a for I/Q points	yes
PStatistic - power statistics CCDF (Basic, cdma2000, 1xEV-DO, W-CDMA modes)	MEASured ($n=2$) ^a GAUSian ($n=3$) ^a REFerence ($n=4$) ^a ($n=0$) ^a for I/Q points	yes
PVTime - power versus time (GSM, EDGE, 1xEV-DO, Service (E4406A only) modes)	($n=0$) ^a for I/Q raw data RFENvelope ($n=2$) ^a UMASk ($n=3$) ^a LMASk ($n=4$) ^a	yes
RHO - modulation quality (cdmaOne, cdma2000, W-CDMA mode)	($n=0$) ^a for I/Q raw data EVM ($n=2$) ^a MERRor ($n=3$) ^a PERRor ($n=4$) ^a ($n=5$) ^a for I/Q corrected trace data	yes

Measurement	Available Traces	Markers Available?
RHO - modulation quality (1xEV-DO mode)	(n=0) ^a for I/Q raw data (n=1) ^a for various summary results EVM (n=2) ^a MERRor (n=3) ^a PERRor (n=4) ^a (n=5) ^a for I/Q corrected trace data	yes
SEMask - spectrum emissions mask (cdma2000, 1xEV-DO, W-CDMA mode)	SPECTrum (n=2) ^a (n=0) ^a for I/Q raw data	yes
TSPur - transmit band spurs (GSM, EDGE mode)	SPECTrum (n=2) ^a ULIMit (n=3) ^a (n=0) ^a for I/Q points	yes
TXPower - transmit power (GSM, EDGE mode)	RFENvelope (n=2) ^a IQ (n=8) ^a (n=0) ^a for I/Q points	yes
SPECTrum - (frequency domain) (all modes)	RFENvelope (n=2) ^a for Service mode (E4406A only) IQ (n=3) ^a SPECTrum (n=4) ^a ASPectrum (n=7) ^a (n=0) ^a for I/Q raw data	yes
WAVEform - (time domain) (all modes)	RFENvelope (n=2) ^a (also for Signal Envelope trace) IQ (n=5) ^a (n=0) ^a for I/Q raw data	yes

- a. The n number indicates the sub-opcode that corresponds to this trace. Detailed descriptions of the trace data can be found in the MEASure subsystem documentation by looking up the sub-opcode for the appropriate measurement.

Terminal Modulation Accuracy Measurement– View Selection

DISPlay:TRHO:VIEW POLar|ERRor|TABLE

DISPlay:TRHO:VIEW?

Select view to display TRHO data.

- POLar - Provides a combination view of the I/Q Measured Polar display and summary data
- ERRor - Provides a combination view of the magnitude error, phase error, EVM Graphs, and summary data
- TABLE - Provides a result table in text display

Factory Preset: POLar

Remarks: You must be in the 1xEV-DO mode to use this command. Use INSTRument:SElect to set the mode.

Waveform - Y-Axis Scale/Div

:DISPlay:WAVEform [n] :WINDow [m] :TRACe:Y[:SCALe] :PDIVision <power>

:DISPlay:WAVEform [n] :WINDow [m] :TRACe:Y[:SCALe] :PDIVision?

Sets the scale per division for the y-axis.

n , selects the view, the default is RF envelope.

$n=1$, $m=1$ RF envelope

$n=2$, $m=1$ I/Q Waveform

$n=2$, $m=1$ I and Q Waveform (Option B7C, E4406A only)

$n=4$, $m=1$ I/Q Polar (Basic, W-CDMA, cdma2000)

$n=5$, $m=1$ Linear Envelope (Option B7C, E4406A only)

m , selects the window within the view. The default is 1.

Factory Preset: 10 dBm, for RF envelope

Range: .1 dB to 20 dB, for RF envelope

Default Unit: dBm, for RF envelope

Remarks: May affect input attenuator setting.

For E4406A to use this command, the appropriate mode should be selected with INSTRUMENT:SElect.

For PSA you must be in Basic, cdmaOne, cdma2000, 1xEV-DO, W-CDMA GSM w/EDGE, NADC, or PDC mode. Set the mode with INSTRUMENT:SElect.

Front Panel
 Access: When in Waveform measurement: **Amplitude Y Scale, Scale/Div.**

History: For PSA:
 Added revision A.02.00

For E4406A:
 Modified revision A.05.00

Waveform - Y-Axis Reference Level

```
:DISPlay:WAVEform [n] :WINDow [m] :TRACe:Y[:SCALE]:RLEVEL
<power>
```

```
:DISPlay:WAVEform [n] :WINDow [m] :TRACe:Y[:SCALE]:RLEVEL?
```

Sets the amplitude reference level for the y-axis.

n, selects the view, the default is RF envelope.

n=1, m=1 RF envelope

n=2, m=1 I/Q Waveform

n=2, m=1 I and Q Waveform (Option B7C, E4406A only)

n=4, m=1 I/Q Polar (Basic, W-CDMA, cdma2000)

n=5, m=1 Linear Envelope (Option B7C, E4406A only)

m, selects the window within the view. The default is 1.

Factory Preset: 0 dBm, for RF envelope

Range: -250 to 250 dBm, for RF envelope

Default Unit: dBm, for RF envelope

Remarks: May affect input attenuator setting.

For E4406A to use this command, the appropriate mode should be selected with INSTRUMENT:SElect.

For PSA you must be in Basic, cdmaOne, cdma2000, 1xEV-DO, W-CDMA GSM w/EDGE, NADC, or PDC

mode. Set the mode with INSTRument:SElect.

Front Panel

Access: When in Waveform measurement: **Amplitude Y Scale, Ref Level**

History: For PSA:
Added revision A.02.00
For E4406A:
Modified revision A.05.00

FETCh Subsystem

The FETCh? queries are used with several other commands to control the measurement process. These commands are described in the section on the “MEASure Group of Commands” on page 339. These commands apply only to measurements found in the MEASURE menu.

This command puts selected data from the most recent measurement into the output buffer (new data is initiated/measured). Use FETCh if you have already made a good measurement and you want to look at several types of data (different [n] values) from the single measurement. FETCh saves you the time of re-making the measurement. You can only fetch results from the measurement that is currently active.

If you need to make a new measurement, use the READ command, which is equivalent to an INITiate[:IMMEDIATE] followed by a FETCh.

:FETCh <meas>? will return valid data only when the measurement is in one of the following states:

- idle
- initiated
- paused

Fetch the Current Measurement Results

:FETCh: <measurement> [n] ?

A FETCh? command must specify the desired measurement. It will return the valid results that are currently available, but will not initiate the taking of any new data. You can only fetch results from the measurement that is currently selected. The code number n selects the kind of results that will be returned. The available measurements and data results are described in the “MEASure Group of Commands” on page 339.

FORMat Subsystem

The FORMat subsystem sets a data format for transferring numeric and array information. For PSA the TRACe[:DATA] command is affected by FORMat subsystem commands.

Byte Order

:FORMat:BORDER NORMAL | SWAPped

:FORMat:BORDER?

Selects the binary data byte order for numeric data transfer. In normal mode the most significant byte is sent first. In swapped mode the least significant byte is first. (PCs use the swapped order.) Binary data byte order functionality does not apply to ASCII.

Factory Preset: Normal

Remarks: You must be in the Basic, cdma2000, 1xEV-DO, W-CDMA, GSM (w/EDGE), NADC, or PDC mode to use this command. Use INSTRument:SElect to set the mode.

Numeric Data Format

PSA/VSA Basic, cdmaOne, cdma2000, 1xEV-DO, W-CDMA, GSM, EDGE, NADC, PDC modes:

:FORMat[:DATA] ASCii | REAL, 32 | REAL, 64

:FORMat[:DATA]?

PSA Spectrum Analysis mode only:

:FORMat[:TRACe] [:DATA]

ASCii | INTeger, 16 | INTeger, 32 | REAL, 32 | REAL, 64 | UINTEger, 16

:FORMat[:TRACe] [:DATA]?

PSA Noise Figure mode only:

:FORMat[:TRACe] [:DATA] ASCii | REAL [, 32]

:FORMat[:TRACe] [:DATA]?

VSA/PSA application modes: This command controls the format of data input/output, that is any data transfer across any remote port. The REAL and ASCII formats will format data in the current display units. The format of state data cannot be changed. It is always in a machine

readable format only.

ASCII - Amplitude values are in ASCII, in amplitude units, separated by commas. ASCII format requires more memory than the binary formats. Therefore, handling large amounts of this type of data, will take more time and storage space.

Integer,16 - Binary 16-bit integer values in internal units (dBm), in a definite length block. **PSA, SA mode only.

Integer,32 - Binary 32-bit integer values in internal units (dBm), in a definite length block.

Real,32 or Real,64 - Binary 32-bit (or 64-bit) real values in amplitude unit, in a definite length block. Transfers of real data are done in a binary block format.

UINTeger,16 - Binary 16-bit unsigned integer that is uncorrected ADC values, in a definite length block. This format is almost never applicable with current measurement data.

A definite length block of data starts with an ASCII header that begins with # and indicates how many additional data points are following in the block. Suppose the header is #512320.

- The first digit in the header (5) tells you how many additional digits/bytes there are in the header.
- The 12320 means 12 thousand, 3 hundred, 20 data bytes follow the header.
- Divide this number of bytes by your selected data format bytes/point, either 8 (for real 64), or 4 (for real 32). In this example, if you are using real 64 then there are 1540 points in the block.

Example: FORM REAL,64

Factory Preset: ASCII

Real,32 for Spectrum Analysis mode

ASCII for Basic, cdmaOne, cdma2000, 1xEV-DO, W-CDMA, GSM with EDGE, NADC, PDC modes

Remarks: The acceptable settings for this command change for the different modes as described above.

INITiate Subsystem

The INITiate subsystem is used to initiate a trigger for a measurement. They only initiate measurements from the MEASURE front panel key or the “MEASure Group of Commands” on page 339. Refer to the TRIGger and ABORt subsystems for related commands.

Take New Data Acquisition for Selected Measurement

:INITiate:<measurement>

For PSA this command is not available for measurements in the instrument modes: Spectrum Analysis, or Phase Noise.

This command initiates a trigger cycle for the measurement specified, but does not return data. The available measurement names are described in the MEASure subsystem..

If your selected measurement is not currently active it will change to the measurement in your INIT:<meas> command and initiate a trigger cycle.

Example: INIT:ACP

Continuous or Single Measurements

:INITiate:CONTinuous OFF|ON|0|1

:INITiate:CONTinuous?

Selects whether a trigger is continuously initiated or not. Each trigger initiates a single, complete, measurement operation.

When set to ON another trigger cycle is initiated at the completion of each measurement.

When set to OFF, the trigger system remains in the “idle” state until an INITiate[:IMMediate] command is received. On receiving the INITiate[:IMMediate] command, it will go through a single trigger/measurement cycle, and then return to the “idle” state.

Example: INIT:CONT ON

Factory Preset: On

*RST: Off (recommended for remote operation)

Front Panel

Access: **Meas Control, Measure Cont Single**

Take New Data Acquisitions

:INITiate[:IMMediate]

The instrument must be in the single measurement mode. If INIT:CONT is ON, then the command is ignored. The desired measurement must be selected and waiting. The command causes the system to exit the “waiting” state and go to the “initiated” state.

The trigger system is initiated and completes one full trigger cycle. It returns to the “waiting” state on completion of the trigger cycle. Depending upon the measurement and the number of averages, there may be multiple data acquisitions, with multiple trigger events, for one full trigger cycle.

This command triggers the instrument, if external triggering is the type of trigger event selected. Otherwise, the command is ignored. Use the TRIGger[:SEQuence]:SOURce EXT command to select the external trigger.

Example: INIT:IMM

Remarks: See also the *TRG command and the TRIGger subsystem.

Front Panel

Access: **Meas Control, Measure Cont Single**

Restart the Measurement

:INITiate:REStart

This command applies to measurements found in the MEASURE menu. It restarts the current measurement from the “idle” state regardless of its current operating state. It is equivalent to:

INITiate[:IMMediate]

ABORt (for continuous measurement mode)

Example: INIT:REST

Front Panel

Access: **Restart**

or

Meas Control, Restart

INSTrument Subsystem

This subsystem includes commands for querying and selecting instrument measurement (personality option) modes.

Catalog Query

For E4406A, `:INSTrument:CATalog[:FULL]?`

For PSA, `:INSTrument:CATalog?`

Returns a comma separated list of strings which contains the names of all the installed applications. These names can only be used with the `INST:SELEct` command.

For E4406A if the optional keyword `FULL` is specified, each name is immediately followed by its associated instrument number. These instrument numbers can only be used with the `INST:NSElect` command.

Example:

(PSA) `INST:CAT?`

Query response: "CDMA"4,"PNOISE"14

Example:

(E4406A) `INST:CAT:FULL?`

Query response:
"BASIC"8,"GSM"3,"CDMA"4,"SERVICE"1

Select Application by Number

`:INSTrument:NSElect <integer>`

`:INSTrument:NSElect?`

Select the measurement mode by its instrument number. The actual available choices depends upon which applications are installed in the instrument. For E4406A these instrument numbers can be obtained with `INST:CATalog:FULL?`

- 1 = SA (PSA)
- 1 = SERVICE (E4406A)
- 3 = GSM (E4406A)
- 4 = CDMA (cdmaOne)
- 5 = NADC
- 6 = PDC
- 8 = BASIC
- 9 = WCDMA (3GPP)

- 10 = CDMA2K (cdma2000)
- 11 = IDEN (E4406A)
- 13 = EDGE GSM
- 14 = PNOISE (phase noise, PSA)
- 15 = CMDA1XEV (1xEV-D0)
- 219 = NOISE FIGURE (PSA)

NOTE

If you are using the SCPI status registers and the analyzer mode is changed, the status bits should be read, and any errors resolved, prior to switching modes. Error conditions that exist prior to switching modes cannot be detected using the condition registers after the mode change. This is true unless they recur after the mode change, although transitions of these conditions can be detected using the event registers.

Changing modes resets all SCPI status registers and mask registers to their power-on defaults. Hence, any event or condition register masks must be re-established after a mode change. Also note that the power up status bit is set by any mode change, since that is the default state after power up.

Example: INST:NSEL 4

Factory Preset: Persistent state with factory default of 1 (PSA)

Persistent state with factory default of 8
(E4406A, BASIC)

Range: 1 to x, where x depends upon which applications are installed.

Front Panel

Access: **MODE**

Select Application

VSA E4406A:

```
:INSTRument[:SElect]
BASIC|SERVICE|CDMA|CDMA2K|GSM|EDGE GSM|IDEN|NADC|PDC|
WCDMA|CDMA1XEV
```

PSA Series:

```
:INSTRument[:SElect]
SA|PNOISE|BASIC|CDMA|CDMA2K|EDGE GSM|NADC|PDC|WCDMA|CDMA1XEV
|NFIGURE
```

```
:INSTRument[:SElect]?
```

Select the measurement mode. The actual available choices depend upon which modes (measurement applications) are installed in the instrument. A list of the valid choices is returned with the INST:CAT?

query.

Once an instrument mode is selected, only the commands that are valid for that mode can be executed.

- 1 = SA (PSA)
- 1 = SERVICE (E4406A)
- 3 = GSM (E4406A)
- 4 = CDMA (cdmaOne)
- 5 = NADC
- 6 = PDC
- 8 = BASIC
- 9 = WCDMA (3GPP)
- 10 = CDMA2K (cdma2000)
- 11 = IDEN (E4406A)
- 13 = EDGE GSM
- 14 = PNOISE (phase noise - PSA)
- 15 = CDMA1XEV (1xEV-DO)
- 219 = NOISE FIGURE (PSA)
- 229 = MAN (Modulation Analysis)
- 231 = LINK (89600 VSA Link software)

NOTE

If you are using the status bits and the analyzer mode is changed, the status bits should be read, and any errors resolved, prior to switching modes. Error conditions that exist prior to switching modes cannot be detected using the condition registers after the mode change. This is true unless they recur after the mode change, although transitions of these conditions can be detected using the event registers.

Changing modes resets all SCPI status registers and mask registers to their power-on defaults. Hence, any event or condition register masks must be re-established after a mode change. Also note that the power up status bit is set by any mode change, since that is the default state after power up.

Example: ESA Series instruments: INST:SEL 'CDMA'

Example: PSA Series instruments: INST:SEL CDMA

Factory Preset:
(PSA) Persistent state with factory default of Spectrum Analyzer mode

Factory Preset:
(E4406A) Persistent state with factory default of Basic mode.

Front Panel
Access: **MODE**

MEASure Group of Commands

This group includes the CONFIgure, FETCh, MEASure, and READ commands that are used to make measurements and return results. The different commands can be used to provide fine control of the overall measurement process, like changing measurement parameters from their default settings. Most measurements should be done in single measurement mode, rather than measuring continuously.

The SCPI default for the format of any data output is ASCII. The format can be changed to binary with FORMat:DATA which transports faster over the bus.

Command Interactions: MEASure, CONFIgure, FETCh, INITiate and READ

Figure 5-3 Measurement Group of Commands

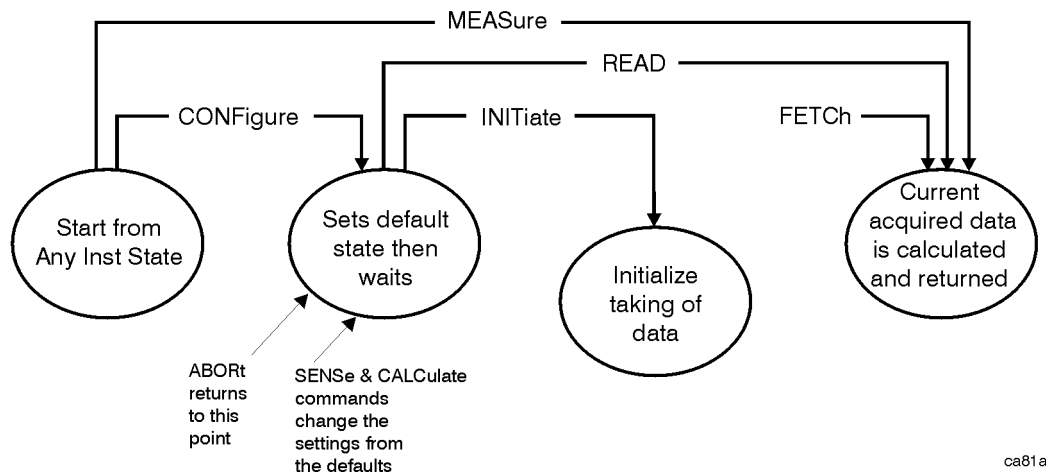

Measure Commands:

:MEASure:<measurement> [n] ?

This is a fast single-command way to make a measurement using the factory default instrument settings. These are the settings and units that conform to the Mode Setup settings (e.g. radio standard) that you have currently selected.

- Stops the current measurement (if any) and sets up the instrument for the specified measurement using the factory defaults
- Initiates the data acquisition for the measurement
- Blocks other SCPI communication, waiting until the measurement is complete before returning results.
- After the data is valid it returns the scalar results, or the trace data, for the specified measurement. The type of data returned may be defined by an [n] value that is sent with the command.

The scalar measurement results will be returned if the optional [n] value is not included, or is set to 1. If the [n] value is set to a value other than 1, the selected trace data results will be returned. See each command for details of what types of scalar results or trace data results are available.

ASCII is the default format for the data output. (Older versions of Spectrum Analysis and Phase Noise mode measurements only use ASCII.) The binary data formats should be used for handling large blocks of data since they are smaller and faster than the ASCII format. Refer to the FORMat:DATA command for more information.

If you need to change some of the measurement parameters from the factory default settings you can set up the measurement with the CONFIgure command. Use the commands in the SENSE:<measurement> and CALCulate:<measurement> subsystems to change the settings. Then you can use the READ? command to initiate the measurement and query the results. See [Figure 5-3](#).

If you need to repeatedly make a given measurement with settings other than the factory defaults, you can use the commands in the SENSE:<measurement> and CALCulate:<measurement> subsystems to set up the measurement. Then use the READ? command to initiate the measurement and query results.

Measurement settings persist if you initiate a different measurement and then return to a previous one. Use READ:<measurement>? if you want to use those persistent settings. If you want to go back to the default settings, use MEASure:<measurement>?.

Configure Commands:

:CONFigure:<measurement>

This command stops the current measurement (if any) and sets up the instrument for the specified measurement using the factory default instrument settings. It sets the instrument to single measurement mode but should not initiate the taking of measurement data unless INIT:CONTinuous is ON. After you change any measurement settings, the READ command can be used to initiate a measurement without changing the settings back to their defaults.

NOTE In instruments with firmware older than A.05.00 CONFigure initiates the taking of data. The data should be ignored. Other SCPI commands can be processed immediately after sending CONFigure. You do not need to wait for the CONF command to complete this 'false' data acquisition.

The CONFigure? query returns the current measurement name.

Fetch Commands:

:FETCh:<measurement> [n] ?

This command puts selected data from the most recent measurement into the output buffer. Use FETCh if you have already made a good measurement and you want to return several types of data (different [n] values, e.g. both scalars and trace data) from a single measurement. FETCh saves you the time of re-making the measurement. You can only FETCh results from the measurement that is currently active, it will not change to a different measurement.

If you need to get new measurement data, use the READ command, which is equivalent to an INITiate followed by a FETCh.

The scalar measurement results will be returned if the optional [n] value is not included, or is set to 1. If the [n] value is set to a value other than 1, the selected trace data results will be returned. See each command for details of what types of scalar results or trace data results are available. The binary data formats should be used for handling large blocks of data since they are smaller and transfer faster than the ASCII format. (FORMat:DATA)

FETCh may be used to return results other than those specified with the original READ or MEASure command that you sent.

INITiate Commands:

:INITiate:<measurement>

This command is not available for measurements in all the instrument modes:

- Initiates a trigger cycle for the specified measurement, but does not output any data. You must then use the **FETCh<meas>** command to return data. If a measurement other than the current one is specified, the instrument will switch to that measurement and then initiate it.
For example, suppose you have previously initiated the ACP measurement, but now you are running the channel power measurement. If you send **INIT:ACP?** it will change from channel power to ACP and will initiate an ACP measurement.
- Does not change any of the measurement settings. For example, if you have previously started the ACP measurement and you send **INIT:ACP?** it will initiate a new ACP measurement using the same instrument settings as the last time ACP was run.
- If your selected measurement is currently active (in the idle state) it triggers the measurement, assuming the trigger conditions are met. Then it completes one trigger cycle. Depending upon the measurement and the number of averages, there may be multiple data acquisitions, with multiple trigger events, for one full trigger cycle. It also holds off additional commands on GPIB until the acquisition is complete.

READ Commands:

:READ:<measurement> [n] ?

- Does not preset the measurement to the factory default settings. For example, if you have previously initiated the ACP measurement and you send **READ:ACP?** it will initiate a new measurement using the same instrument settings.
- Initiates the measurement and puts valid data into the output buffer. If a measurement other than the current one is specified, the instrument will switch to that measurement before it initiates the measurement and returns results.

For example, suppose you have previously initiated the ACP measurement, but now you are running the channel power measurement. Then you send **READ:ACP?** It will change from channel power back to ACP and, using the previous ACP settings, will initiate the measurement and return results.

- Blocks other SCPI communication, waiting until the measurement is complete before returning the results

If the optional [n] value is not included, or is set to 1, the scalar measurement results will be returned. If the [n] value is set to a value other than 1, the selected trace data results will be returned. See each command for details of what types of scalar results or trace data results are available. The binary data formats should be used when handling large blocks of data since they are smaller and faster than the ASCII format. (**FORMat:DATA**)

Code Domain Power Measurement

This measures the power levels of the spread channels in RF channel(s). You must be in the cdmaOne, cdma2000, W-CDMA, or 1xEV-DO mode to use these commands. Use INSTRUMENT:SElect to set the mode.

For 1xEV-DO, this measurement is used only for base stations (Network Access). When measuring 1xEV-DO mobile stations (Access Terminals) use Terminal Code Domain Measurements (MEAS:TCDPower) and set SENSE:RADio:DEvice to MS.

The general functionality of CONFigure, FETCh, MEASure, and READ are described at the beginning of this section. See the SENSE:CDPower commands for more measurement related commands.

```
:CONFigure:CDPower
:INITiate:CDPower
:FETCh:CDPower [n] ?
:READ:CDPower [n] ?
:MEASure:CDPower [n] ?
```

Front Panel

Access: **Measure, Code Domain**

After the measurement is selected, press **Restore Meas Defaults** to restore factory defaults.

Measurement Results Available

n	Results Returned
0	Returns unprocessed I/Q trace data, as a series of trace point values, in volts. The I values are listed first in each pair, using the 0 through even-indexed values. The Q values are the odd-indexed values.

n	Results Returned
n=1 (or not specified) cdmaOne mode	<p>Returns the following 25 scalar results:</p> <ol style="list-style-type: none"> 1. Time offset is a floating point number with units of seconds. This is the time delay of the even second clock with respect to the start of the short code PN sequences, at offsets from the 15 zeros in the characteristic phase of the sequences. 2. Frequency error is a floating point number (in Hz) of the frequency error in the measured signal. This error is based on the linear best fit of the uncorrected measured phase. 3. Carrier feedthrough is a floating point number (in dB) of the dc offset, of I and Q, from the origin. 4. Pilot power is a floating point number with units of dB. It is the relative power of the pilot channel (Walsh code 0) with respect to the carrier power. 5. Paging power is a floating point number with units of dB. It is the relative power of the paging channel (Walsh code 1) with respect to the carrier power. 6. Sync power is a floating point number with units of dB. It is the relative power of the sync channel (Walsh code 32) with respect to the carrier power. 7. Average traffic power is a floating point number with units of dB. It is the average relative power of the active traffic channels with respect to the carrier power. Traffic channels are defined as all of the Walsh codes except Walsh 0,1,32. A traffic channel is active if its coding power is greater than the active threshold parameter which you have selected. 8. Maximum inactive traffic power is a floating point number with units of dB. It is the maximum relative power of an inactive traffic channel with respect to the carrier power. Traffic channels are defined as all of the Walsh codes except Walsh 0,1,32. A traffic channel is inactive if its coding power is less than the active threshold parameter which you have selected. 9. Average inactive traffic power is a floating point number with units of dB. It is the average relative power of the inactive traffic channels with respect to the carrier power. Traffic channels are defined as all of the Walsh codes except Walsh 0,1,32. A traffic channel is inactive if its coding power is less than the active threshold parameter which you have selected. 10. Marker Values The last 16 measurement results are the current values for all four available markers. The values are zero for any marker that is not active. <ol style="list-style-type: none"> 10. Marker 1 position (code number) 11. Marker 1 power level 12. Marker 1 time value 13. Marker 1 phase value . . . 25. Marker 4 phase value

n	Results Returned
n=1 (or not specified) cdma2000 mode	<p>Returns the following 19 scalar results:</p> <ol style="list-style-type: none"> 1. RMS symbol EVM is a floating point number (in percent) of the EVM over the entire measurement area. 2. Peak symbol EVM is a floating point number (in percent) of the peak EVM in the measurement area. 3. Symbol magnitude error is a floating point number (in percent) of the average magnitude error over the entire measurement area. 4. Symbol phase error is a floating point number (in degrees) of the average phase error over the entire measurement area. 5. Total power is a floating point number (in dBm) of the total RF power over the measurement interval. 6. Channel power is a floating point number (in dBc or dBm depending on the measurement type, see below) of the power in the entire slot, for the selected code, averaged over the measurement interval. NOTE: When measurement type = rel, then the value displayed is in units of dBc, and the relative power is calculated as the ratio of the Channel Power to the Total Power (parameter 5 above). 7. Total active power is a floating point number (in dB or dBm depending on the measurement type) of the sum of the active power. 8. Pilot power is a floating point number (in dB or dBm depending on the measurement type) of the average power of the Pilot code. 9. Sync power is a floating point number (in dB or dBm depending on the measurement type) of the average power of the Sync code. In the MS mode, the value returned is -999. 10. Maximum active traffic power is a floating point number (in dB or dBm depending on the measurement type) of the maximum average power of the active code. If no active code is detected the value returned is -999. In the MS mode, the value returned is -999. 11. Average active traffic power is a floating point number (in dB or dBm depending on the measurement type) of the average power of all the active traffic channels. If no active code is detected the value returned is -999. In the MS mode, the value returned is -999. 12. Maximum inactive traffic power is a floating point number (in dB or dBm depending on the measurement type) of the maximum average power of the inactive traffic channels. In the MS mode, the value returned is -999. 13. Average inactive traffic power is a floating point number (in dB or dBm depending on the measurement type) of the average power of the inactive traffic channels. In the MS mode, the value returned is -999. 14. Number of active channel In the MS mode, the value returned is -999.

n	Results Returned
n=1 (or not specified) cdma2000 mode (continued)	<p>15. I channel average active power is a floating point number (in dB or dBm depending on the measurement type) of the average power of the active I channels. In the BS mode, the value returned is -999.</p> <p>16. I channel maximum inactive power is a floating point number (in dB or dBm depending on the measurement type) of the maximum average power of the inactive I channels. In the BS mode, the value returned is -999.</p> <p>17. Q channel average active power is a floating point number (in dB or dBm depending on the measurement type) of the average power of the active Q channels. In the BS mode, the value returned is -999.</p> <p>18. Q channel maximum inactive power is a floating point number (in dB or dBm depending on the measurement type) of the maximum average power of the inactive Q channels. In the BS mode, the value returned is -999.</p> <p>19. Time between trigger to PN Offset is a floating point number (in μs) of the time from the trigger point to the PN Offset. In the MS mode, the value returned is -999.</p>

n	Results Returned
n=1 (or not specified) W-CDMA mode	<p>Returns the following 31 scalar results:</p> <ol style="list-style-type: none"> 1. RMS symbol EVM is a floating point number (in percent) of the EVM over the entire measurement area. 2. Peak symbol EVM is a floating point number (in percent) of the peak EVM in the measurement area. 3. Symbol magnitude error is a floating point number (in percent) of the average magnitude error over the entire measurement area. 4. Symbol phase error is a floating point number (in degrees) of the average phase error over the entire measurement area. 5. Total power is a floating point number (in dBm) of the total RF power over the measurement interval. 6. Channel power is a floating point number (in dBc or dBm depending on the measurement type, see below) of the power in the entire slot, for the selected code, averaged over the measurement interval. NOTE: When measurement type = rel, then the value displayed is in units of dBc, and the relative power is calculated as the ratio of the Channel Power to the Total Power (parameter 5 above). 7. tDPCH is a floating point number (in 256 chips) of dedicated physical channel (DPCH) delay time from the reference. (tDPCH equals T_n) 8. Total power over a slot is a floating point number (in dBm) of total RF power over the measurement interval. (SCH is excluded.) 9. Total active power is a floating point number (in dB or dBm depending on the measurement type) of the sum of the active power. (SCH is excluded.) 10. Pilot power is a floating point number (in dB or dBm depending on the measurement type) of the average power of the CPICH code relative to the total slot power. In the MS mode, the value returned is -999. (SCH is excluded.) 11. Maximum active traffic power is a floating point number (in dB or dBm depending on the measurement type) of the maximum average power of the active traffic channels. If no active code is detected the value returned is -999. In the MS mode, the value returned is -999. (SCH is excluded.) 12. Average active traffic power is a floating point number (in dB or dBm depending on the measurement type) of the average power of all the active traffic channels. If no active code is detected the value returned is -999. In the MS mode, the value returned is -999. (SCH is excluded.) 13. Maximum inactive traffic power is a floating point number (in dB or dBm depending on the measurement type) of the maximum average power of the inactive traffic channels. The slot timing is determined by Perch. In the MS mode, the value returned is -999. (SCH is excluded.)

n	Results Returned
<p>n=1 (or not specified) W-CDMA mode (continued)</p>	<p>14. Average inactive traffic power is a floating point number (in dB or dBm depending on the measurement type) of the average power of the inactive traffic channels. In the MS mode, the value returned is -999. (SCH is excluded.)</p> <p>15. Number of active channel In the MS mode, the value returned is -999.</p> <p>16. P-SCH is a floating point number (in dBm) of the primary synchronization channel power. In the MS mode, the value returned is -999.</p> <p>17. S-SCH is a floating point number (in dBm) of the secondary synchronization channel power. In the MS mode, the value returned is -999.</p> <p>18. DPCCH Power is a floating point number (in dB or dBm depending on the measurement type) of the average power of dedicated physical control channel (DPCCH). In the BS mode, the value returned is -999. When PRACH is measured, this returns control part power.</p> <p>19. DPCCH Beta Nominal is a floating point number of the nominal beta value of DPCCH Beta factor. In the BS mode, the value returned is -999. When PRACH is measured, this returns control part Beta nominal.</p> <p>20. DPCCH Beta Measured is a floating point number of the measured value of the DPCCH Beta factor. In the BS mode, the value returned is -999. When PRACH is measured, this returns control part Beta measured.</p> <p>21. DPDCH Beta Nominal is a floating point number of the nominal beta value of the dedicated physical data channel (DPDCH) Beta factor. In the BS mode, the value returned is -999. When PRACH is measured, this returns control part Beta nominal.</p> <p>22. DPDCH Beta 1 Measured is a floating point number of the measured value of the DPDCH (C1) Beta factor. In the BS mode, the value returned is -999. When PRACH is measured, this returns control part Beta measured.</p> <p>23. DPDCH Beta 2 Measured is a floating point number of the measured value of the DPDCH (C2) Beta factor. In the BS mode, the value returned is -999. When PRACH is measured, this returns -999.</p> <p>24. DPDCH Beta 3 Measured is a floating point number of the measured value of the DPDCH (C3) Beta factor. In the BS mode, the value returned is -999. When PRACH is measured, this returns -999.</p> <p>25. DPDCH Beta 4 Measured is a floating point number of the measured value of the DPDCH (C4) Beta factor. In the BS mode, the value returned is -999. When PRACH is measured, this returns -999.</p> <p>26. DPDCH Beta 5 Measured is a floating point number of the measured value of the DPDCH (C5) Beta factor. In the BS mode, the value returned is -999. When PRACH is measured, this returns -999.</p>

n	Results Returned
n=1 (or not specified) W-CDMA mode (continued)	<p>27. DPDCH Beta 6 Measured is a floating point number of the measured value of the DPDCH (C6) Beta factor. In the BS mode, the value returned is -999. When PRACH is measured, this returns -999.</p> <p>28. I channel average active power is a floating point number (in dB or dBm depending on the measurement type) of the average power of the active I channels. In the BS mode, the value returned is -999.</p> <p>29. I channel maximum inactive power is a floating point number (in dB or dBm depending on the measurement type) of the maximum average power of the inactive I channels. In the BS mode, the value returned is -999.</p> <p>30. Q channel average active power is a floating point number (in dB or dBm depending on the measurement type) of the average power of the active Q channels. In the BS mode, the value returned is -999.</p> <p>31. Q channel maximum inactive power is a floating point number (in dB or dBm depending on the measurement type) of the maximum average power of the inactive Q channels. In the BS mode, the value returned is -999.</p>

n	Results Returned
n=1 (or not specified) 1xEV-DO mode	<p>Returns the following 18 comma-delimited scalar results, in the following order:</p> <ol style="list-style-type: none"> 1. Total power is a floating point number (in dBm) of the total RF power over the measurement interval. NOTE: The following power results are computed by the CDP measurement. The unit used in the computation, either dB or dBm, is determined by the setting of the CALCulate:CDPower:TYPE command. When the selection is ABSolute, the unit used is dBm. When the selection is RELative, the unit used is dB relative to Total Power (above). 2. Total active power is a floating point number (in dB or dBm depending on the measurement type) of the sum of the active powers (–.999.0 when no active channel is detected). 3. Maximum active power is a floating point number (in dB or dBm depending on the measurement type) of the maximum average power of the active code (–.999.0 when no active channel is detected in I/Q Combined=On mode. Always –.999.0 in I/Q Combined=Off mode) 4. Average active power is a floating point number (in dB or dBm depending on the measurement type) of the average power of all the active traffic channels (–.999.0 when no active channel is detected in I/Q Combined=On mode. Always –.999.0 in I/Q Combined=Off mode). 5. Maximum inactive power is a floating point number (in dB or dBm depending on the measurement type) of the maximum average power of the inactive traffic channels. (–.999.0 in I/Q Combined=Off mode) 6. Average inactive power is a floating point number (in dB or dBm depending on the measurement type) of the average power of the inactive traffic channels. (–.999.0 in I/Q Combined=Off mode) 7. Number of active channels 8. I channel average active power is a floating point number (in dB or dBm depending on the measurement type) of the average power of the active I channels. (–.999.0 when I/Q Combined=On mode or when no active channel is detected in I/Q Combined=Off mode). 9. I channel maximum inactive power is a floating point number (in dB or dBm depending on the measurement type) of the maximum average power of the inactive I channels. (–.999.0 when I/Q Combined=On mode) 10. Q channel average active power is a floating point number (in dB or dBm depending on the measurement type) of the average power of the active Q channels. (–.999.0 when I/Q Combined=On mode or when no active channel is detected in I/Q Combined=Off mode). 11. Q channel maximum inactive power is a floating point number (in dB or dBm depending on the measurement type) of the maximum average power of the inactive Q channels. (–.999.0 when I/Q Combined=On mode)

n	Results Returned
<p>n=1 (or not specified) 1xEV-DO mode (continued)</p>	<p>12. Preamble Length is a floating point number (in chips).</p> <p>13. Preamble MAC Index is an integer number of MAC index.</p> <p>14. Minimum Active Power is a floating point number (in dB or dBm depending on the measurement type) of the minimum average power of the active code (–.999.0 when no active channel is detected in I/Q Combined=On mode. Always –.999.0 in I/Q Combined=Off mode)</p> <p>15. I channel maximum inactive power is a floating point number (in dB or dBm depending on the measurement type) of the maximum average power of the inactive I channels. (–.999.0 when I/Q Combined=On mode)</p> <p>16. I channel minimum inactive power is a floating point number (in dB or dBm depending on the measurement type) of the minimum average power of the inactive I channels. (–.999.0 when I/Q Combined=On mode)</p> <p>17. Q channel maximum inactive power is a floating point number (in dB or dBm depending on the measurement type) of the maximum average power of the inactive Q channels. (–.999.0 when I/Q Combined=On mode)</p> <p>18. Q channel minimum inactive power is a floating point number (in dB or dBm depending on the measurement type) of the minimum average power of the inactive Q channels. (–.999.0 when I/Q Combined=On mode)</p>
<p>2 cdmaOne mode</p>	<p>Returns floating point numbers that are the trace data of the code domain <i>power</i> trace for all 64 Walsh codes. This series of 64 numbers represent the relative power levels (in dB) of all 64 walsh codes, with respect to the carrier power.</p>

n	Results Returned
2 cdma2000 mode	<p>Returns a series of floating point numbers (in dB or dBm depending on the measurement type) that represents all the code domain powers.</p> <p>With a device of BTS, there are 64 or 128 numbers depending on CALCulate:CDPower:WCODE:BASE. If the active channel occupies more than the max spreading factor (64 or 128 Walsh Code length depending on CALCulate:CDPower:WCODE:BASE) the power is duplicated (CALCulate:CDPower:WCODE:BASE / active Walsh code length) times.</p> <p>1st number = 1st code power over the slot 2nd number = 2nd code power over the slot ... Nth number = Nth code power over the slot</p> <p>With a device of MS, there are 256 I/Q pairs. If the active channel occupies more than the max spreading factor (C8) the power is duplicated (active Cx / C8) times.</p> <p>1st number = 1st in-phase code power over the slot 2nd number = 1st quad-phase code power over the slot ... (2×N-1)th number = Nth in-phase code power over the slot (2×N)th number = Nth quad-phase code power over a slot</p> <p>N = the number of codes detected. The total number of codes varies because of the different symbol rates of each code.</p>
2 1xEV-DO mode	<p>Returns a series of floating point numbers (in dB or dBm depending on the measurement type) that represents all the code domain powers.</p> <p>When I/Q Combined=On, total is 16 for Data, 32 for Pilot, and 64 for MAC. If the active channel occupies more than the max spreading factor (16 for Data, 32 for Pilot, and 64 for MAC) the power is duplicated.</p> <p>1st number = 1st code power over the slot 2nd number = 2nd code power over the slot ... Nth number = Nth code power over the slot</p> <p>When I/Q Combined=Off, results are returned alternatively. Total is 16 I/Q pairs for Data, 32 for Pilot, and 64 for MAC. If the active channel occupies more than the max spreading factor (16 for Data, 32 for Pilot, and 64 for MAC) the power is duplicated.</p> <p>1st number = 1st in-phase code power over the slot 2nd number = 1st quad-phase code power over the slot ... (2×N-1)th number = Nth in-phase code power over the slot (2×N)th number = Nth quad-phase code power over a slot</p> <p>N = the number of codes detected. The total number of codes varies because of the different symbol rates of each code.</p>

n	Results Returned
2 W-CDMA.mode	<p>Returns a series of floating point numbers (in dB or dBm depending on the measurement type) that represents all the code domain powers.</p> <p>With a device of BTS, there are 512 numbers. If the active channel occupies more than the max spreading factor (7.5 ksp/s) the power is duplicated (active symbol rate/7.5 ksp/s) times.</p> <p style="padding-left: 40px;">1st number = 1st code power over the slot 2nd number = 2nd code power over the slot ... Nth number = Nth code power over the slot</p> <p>With a device of MS, there are 256 I/Q pairs. If the active channel occupies more than the max spreading factor (15 ksp/s) the power is duplicated (active symbol rate / 15 ksp/s) times.</p> <p style="padding-left: 40px;">1st number = 1st in-phase code power over the slot 2nd number = 1st quad-phase code power over the slot ... (2×N-1)th number = Nth in-phase code power over the slot (2×N)th number = Nth quad-phase code power over a slot</p> <p>N = the number of codes detected. The total number of codes varies because of the different symbol rates of each code.</p>
3 cdmaOne mode	<p>Returns floating point numbers that are the trace data of the code domain <i>timing</i> trace for all 64 Walsh codes. This series of 64 numbers represent the relative timing estimations (in seconds) of the codes, relative to the pilot channel. Typical values are on the order of 1 ns.</p>

n	Results Returned
3 cdma2000 mode	<p>Returns a series of floating point numbers (in symbol rate) that represent all code domain symbol rates.</p> <p>With a device of BTS, there are 64 or 128 numbers depending on CALCulate:CDPower:WCODE:BASE. If the active channel occupies more than the max spreading factor (64 or 128 Walsh code length depending on CALCulate:CDPower:WCODE:BASE) the power is duplicated (CALCulate:CDPower:WCODE:BASE / active Walsh code length) times.</p> <p>1st number = 1st code symbol rate over the slot 2nd number = 2nd code symbol rate over the slot ... Nth number = Nth code symbol rate over the slot</p> <p>With a device of MS, there are 256 I/Q pairs. If the active channel occupies more than the max spreading factor (C8) the power is duplicated (active Cx / C8) times.</p> <p>1st number = 1st in-phase code symbol rate over the slot 2nd number = 1st quad-phase code symbol rate over the slot ... (2×N-1)th number = Nth in-phase code symbol rate over the slot (2×N)th number = Nth quad-phase code symbol rate over the slot</p> <p>N = the number of codes detected. The total number of codes varies because of the different symbol rates of each code.</p>
3 1xEV-DO mode	<p>Returns a series of floating point numbers (in dB or dBm depending on the measurement type) that represents all the code domain symbol rates.</p> <p>When I/Q Combined=On, total is 16 for Data, 32 for Pilot, and 64 for MAC. If the active channel occupies more than the max spreading factor (16 for Data, 32 for Pilot, and 64 for MAC) the power is duplicated.</p> <p>1st number = 1st code symbol rate over the slot 2nd number = 2nd code symbol rate over the slot ... Nth number = Nth code symbol rate over the slot</p> <p>When I/Q Combined=Off, results are returned alternatively. Total is 16 I/Q pairs for Data, 32 for Pilot, and 64 for MAC. If the active channel occupies more than the max spreading factor (16 for Data, 32 for Pilot, and 64 for MAC) the power is duplicated.</p> <p>1st number = 1st in-phase code symbol rate over the slot 2nd number = 1st quad-phase code symbol rate over the slot ... (2×N-1)th number = Nth in-phase code symbol rate over the slot (2×N)th number = Nth quad-phase code symbol rate over a slot</p> <p>N = the number of codes detected. The total number of codes varies because of the different symbol rates of each code.</p>

n	Results Returned
<p>3 W-CDMA mode</p>	<p>Returns a series of floating point numbers (in symbol rate) that represent all code domain symbol rates.</p> <p>With a device of BTS, there are 512 numbers. If the active channel occupies more than the max spreading factor (7.5 ksp/s) the power is duplicated (active symbol rate/7.5 ksp/s) times.</p> <p>1st number = 1st code symbol rate over the slot 2nd number = 2nd code symbol rate over the slot ... Nth number = Nth code symbol rate over the slot</p> <p>With a device of MS, there are 256 I/Q pairs. If the active channel occupies more than the max spreading factor (15 ksp/s) the power is duplicated (active symbol rate/15 ksp/s) times.</p> <p>1st number = 1st in-phase code symbol rate over the slot 2nd number = 1st quad-phase code symbol rate over the slot ... (2×N-1)th number = Nth in-phase code symbol rate over the slot (2×N)th number = Nth quad-phase code symbol rate over the slot</p> <p>N = the number of codes detected. The total number of codes varies because of the different symbol rates of each code.</p>
<p>4 cdmaOne mode</p>	<p>Returns floating point numbers that are the trace data of the code domain <i>phase</i> trace for all 64 Walsh codes. This series of 64 numbers represent the relative phase estimations (in radians) of the codes, relative to the pilot channel. Typical values are on the order of 1 mrad.</p>
<p>4 cdma2000 or W-CDMA mode</p>	<p>Returns a series of floating point numbers that show either active or inactive status for each of the code powers returned in n=2. (See above.) If a code is inactive, the value returned is 0.0, otherwise a value >0.0 is returned.</p> <p>1st number = active or inactive flag of the 1st code ... Nth number = active or inactive flag of the Nth code</p> <p>(where N= the number of codes identified)</p>

n	Results Returned
4 1xEV-DO mode	<p>Returns a series of floating point numbers that show either active or inactive status for each of the code powers returned in n=2 and 3. If a code is inactive, the value returned is 0.0, otherwise a value >0.0 is returned.</p> <p>When I/Q Combined=On, I/Q combined results are returned. 1st number = active or inactive flag of the 1st code ... Nth number = active or inactive flag of the Nth code</p> <p>When channel type=Pilot or MAC, results are returned alternatively. 1st number = 1st in-phase code active flag 2nd number = 1st Quad Phase code active flag ... (2×N-1)th number = Nth in-phase code active flag (2×N)th number = Nth Quad Phase code active flag</p> <p>N = the number of codes detected. The total number of codes varies because of the different symbol rates of each code. 2nd number = 1st quad-phase code symbol rate over the slot</p>
5 cdma2000, or W-CDMA mode	<p>Returns a series of floating point numbers (in percent) that represent each sample in the <i>EVM</i> trace. The first number is the symbol 0 decision point and there are X points per symbol. Therefore, the decision points are at 0, 1×X, 2×X, 3×X. . .</p> <p>(where X = the number of points per chip)</p>
5 1xEV-DO mode	<p>Returns series of floating point numbers that alternately represent I and Q pairs of the <i>corrected measured</i> trace. The magnitude of each I and Q pair is normalized to 1.0. The first number is the in-phase (I) sample of symbol 0 decision point and the second is the quadrature-phase (Q) sample of symbol 0 decision point. As in the EVM, there are X points per symbol, so that:</p> <p>1st number is I of the symbol 0 decision point 2nd number is Q of the symbol 0 decision point ... (2×X)+1 number is I of the symbol 1 decision point (2×X)+2 number is Q of the symbol 1 decision point ... (2×X)×N+1th number is I of the symbol N decision point (2×X)×N+2th number is Q of the symbol N decision point</p> <p>where X = the number of points per symbol, and N = the number of symbols</p>
6 cdma2000, or W-CDMA mode	<p>Returns a series of floating point numbers (in percent) that represent each sample in the <i>magnitude error</i> trace. The first number is the symbol 0 decision point and there are X points per symbol. Therefore, the decision points are at 0, 1×X, 2×X, 3×X. . .</p> <p>(where X = the number of points per chip)</p>

n	Results Returned
6 1xEV-DO mode	Returns series of floating point numbers (in dBm) that represent the trace data of the chip power vs. time.
7 cdma2000, or W-CDMA mode	Returns a series of floating point numbers (in degrees) that represent each sample in the <i>phase error</i> trace. The first number is the symbol 0 decision point and there are X points per symbol. Therefore, the decision points are at 0, 1×X, 2×X, 3×X. . . (where X = the number of points per chip)
8 cdma2000, or W-CDMA mode	Returns series of floating point numbers that alternately represent I and Q pairs of the <i>corrected measured</i> trace. The magnitude of each I and Q pair is normalized to 1.0. The first number is the in-phase (I) sample of symbol 0 decision point and the second is the quadrature-phase (Q) sample of symbol 0 decision point. As in the EVM, there are X points per symbol, so that: 1st number is I of the symbol 0 decision point 2nd number is Q of the symbol 0 decision point ... (2×X)+1 number is I of the symbol 1 decision point (2×X)+2 number is Q of the symbol 1 decision point ... (2×X)×N+1th number is I of the symbol N decision point (2×X)×N+2th number is Q of the symbol N decision point where X = the number of points per symbol, and N = the number of symbols
9 cdma2000, or W-CDMA mode	Returns series of floating point numbers (in dBm) that represent the trace data of the symbol power vs. time.
10 cdma2000, or W-CDMA mode	Returns series of floating point numbers (in dBm) that represent the trace data of the chip power vs. time.
11 cdma2000	Returns a series of floating point numbers (0.0 or 1.0) of the symbol values (demodulated bits) for the selected spread code. The results are returned as alternating values of I,Q,I,Q . . . for the entire measurement interval.
11 W-CDMA mode	Returns series of floating point numbers (0.0 or 1.0) of symbol values for the selected code with the entire capture length, when :CALCulate:CDPower:DBITs[:FORMat] is set to BINary. Returns series of floating point numbers (0.0, 1.0 or -1.0) of symbol values for the selected code with the entire capture length, when :CALCulate:CDPower:DBITs[:FORMat] is set to TRISate. “-1.0” represents DTX (Discontinuous Transmission) bit.

n	Results Returned
12 W-CDMA mode	Returns series of floating point numbers (0.0 or 1.0) of symbol values for the selected code with the period selected by Meas Interval, and Meas Offset and tDPCH, when :CALCulate:CDPower:DBITs[:FORMat] is set to BINary. Returns series of floating point numbers (0.0, 1.0 or -1.0) of symbol values for the selected code with the period selected by Meas Interval, and Meas Offset and tDPCH, when :CALCulate:CDPower:DBITs[:FORMat] is set to TRIState. “-1.0” represents DTX (Discontinuous Transmission) bit.

Channel Power Measurement

For E4406A this measures the total rms power in a specified integration bandwidth. You must be in the Basic, cdmaOne, cdma2000, W-CDMA, or 1xEV-DO mode to use these commands. Use INSTRUMENT:SElect to set the mode.

For PSA this measures the total rms power in a specified integration bandwidth. You must be in the cdmaOne, cdma2000, or W-CDMA, or 1xEV-DO mode to use these commands. Use INSTRUMENT:SElect to set the mode.

The general functionality of CONFigure, FETCh, MEASure, and READ are described at the beginning of this section. See the SENSE:CHPower commands for more measurement related commands.

```
:CONFigure:CHPower
:INITiate:CHPower
:FETCh:CHPower [n] ?
:READ:CHPower [n] ?
:MEASure:CHPower [n] ?
```

History: For E4406A:
 Added to Basic mode, version A.03.00 or later

Front Panel

Access: **Measure, Channel Power**

After the measurement is selected, press **Restore Meas Defaults** to restore factory defaults.

Measurement Results Available

n	Results Returned
0	Returns unprocessed I/Q trace data, as a series of trace point values, in volts. The I values are listed first in each pair, using the 0 through even-indexed values. The Q values are the odd-indexed values.
n=1 (or not specified)	Returns 2 scalar results: 1. Channel Power is a floating point number representing the total channel power in the specified integration bandwidth. 2. PSD (Power Spectral Density) is the power (in dBm/Hz) in the specified integration bandwidth.
2	Returns floating point numbers that are the captured trace data of the power (in dBm/resolution BW) of the signal. The frequency span of the captured trace data is specified by the Span key.

QPSK Error Vector Magnitude Measurement

This measures the QPSK error vector magnitude of each symbol. You must be in the cdma2000, W-CDMA, or 1xEV-DO mode to use these commands. Use INSTRument:SElect to set the mode.

The general functionality of CONFigure, FETCh, MEASure, and READ are described at the beginning of this section. See the SENSE:EVMQpsk commands for more measurement related commands.

:CONFigure:EVMQpsk

:INITiate:EVMQpsk

:FETCh:EVMQpsk [n] ?

:READ:EVMQpsk [n] ?

:MEASure:EVMQpsk [n] ?

History: Version A.03.00 or later

Front Panel

Access: **Measure, QPSK EVM**

After the measurement is selected, press **Restore Meas Defaults** to restore factory defaults.

Measurement Results Available

n	Results Returned
0	Returns unprocessed I/Q trace data, as a data array of trace point values, in volts.

n	Results Returned
1 (default)	<p>Returns 11 scalar results, in the following order.</p> <ol style="list-style-type: none"> 1. RMS EVM is a floating point number (in percent) of EVM over the entire measurement area. 2. RMS EVM maximum is the maximum RMS EVM over the averaged counts 3. Peak EVM is a floating point number (in percent) of peak EVM in the measurement area. 4. Peak EVM maximum is the maximum peak EVM over the averaged counts. 5. Magnitude error is a floating point number (in percent) of average magnitude error over the entire measurement area. 6. Magnitude error maximum is the maximum magnitude error over the averaged counts. 7. Phase error is a floating point number (in degree) of average phase error over the entire measurement area. 8. Phase error maximum is the maximum phase error over the averaged counts. 9. Frequency error is a floating point number (in Hz) of the frequency error in the measured signal. 10. Frequency error maximum is the maximum frequency error over the averaged counts. 11. I/Q origin offset is a floating point number (in dB) of the I and Q error (magnitude squared) offset from the origin.
2	<p>EVM trace – returns series of floating point numbers (in percent) that represent each sample in the EVM trace. The first number is the symbol 0 decision point. There are X points per symbol ($X = \text{points/chip}$). Therefore, the decision points are at $0, 1 \times X, 2 \times X, 3 \times X \dots$</p>
3	<p>Magnitude error trace – returns series of floating point numbers (in percent) that represent each sample in the magnitude error trace. The first number is the symbol 0 decision point. There are X points per symbol ($X = \text{points/chip}$). Therefore, the decision points are at $0, 1 \times X, 2 \times X, 3 \times X \dots$</p>
4	<p>Phase error trace – returns series of floating point numbers (in degree) that represent each sample in the phase error trace. There are X points per symbol ($X = \text{points/ chip}$). Therefore, the decision points are at $0, 1 \times X, 2 \times X, 3 \times X \dots$</p>

n	Results Returned
5	<p>Corrected measured trace – returns series of floating point numbers that alternately represent I and Q pairs of the corrected measured trace. The magnitude of each I and Q pair are normalized to 1.0. The first number is the in-phase (I) sample of symbol 0 decision point and the second is the quadrature-phase (Q) sample of symbol 0 decision point. There are X points per symbol ($X = \text{points/chip}$), so the series of numbers is:</p> <p>1st number = I of the symbol 0 decision point 2nd number = Q of the symbol 0 decision point</p> <p style="text-align: center;">. . .</p> <p>$(2 \times X) + 1$, number = I of the symbol 1 decision point $(2 \times X) + 2$, number = Q of the symbol 1 decision point</p> <p style="text-align: center;">. . .</p> <p>$(2 \times X) \times N\text{th} + 1$ number = I of the symbol N decision point $(2 \times X) \times N\text{th} + 2$ number = Q of the symbol N decision point</p>

Intermodulation Measurement

This measures the third order and fifth order intermodulation products caused by the wanted signal and the interfering signal. You must be in cdma2000, W-CDMA, or 1xEV-DO mode to use these commands. Use INSTRument:SElect to set the mode.

The general functionality of CONFigure, FETCh, MEASure, and READ are described at the beginning of this section. See the SENSE:IM commands for more measurement related commands.

:CONFigure:IM

:INITiate:IM

:FETCh:IM[n]?

:READ:IM[n]?

:MEASure:IM[n]?

Front Panel

Access: **Measure, Intermod**

After the measurement is selected, press **Restore Meas Defaults** to restore factory defaults.

Measurement Results Available

n	Results Returned
0	Returns unprocessed I/Q trace data that acquired in the last acquisition when multiple acquisition is performed, as a data array of trace point values, in volts.

n	Results Returned
1 (default)	<p>Returns 23 scalar results in the following order.</p> <ol style="list-style-type: none"> 1. Absolute power of the reference (dBm) 2. Base lower frequency (Hz) 3. Base lower absolute power (dBm) 4. Base lower relative power to the reference (dBc) 5. Base upper frequency (Hz) 6. Base upper absolute power (dBm) 7. Base upper relative power to the reference (dBc) 8. Third order lower frequency (Hz) 9. Third order lower absolute power (dBm) 10. Third order lower relative power to the reference power (dBc) 11. Third order lower power spectrum density (dBm/Hz) 12. Third order upper frequency (Hz) 13. Third order upper absolute power (dBm) 14. Third order upper relative power to the reference power (dBc) 15. Third order upper power spectrum density (dBm/Hz) 16. Fifth order lower frequency (Hz) 17. Fifth order lower absolute power (dBm) 18. Fifth order lower relative power to the reference power (dBc) 19. Fifth order lower power spectrum density (dBm/Hz) 20. Fifth order upper frequency (Hz) 21. Fifth order upper absolute power (dBm) 22. Fifth order upper relative power to the reference power (dBc) 23. Fifth order upper power spectrum density (dBm/Hz) <p>If the results are not available, -999.0 is returned for the power results and 0.0 for the frequency results.</p>
2 cdma2000, 1xEV-DO mode	<p>Returns a series of floating point numbers that represent the frequency-domain spectrum trace for the entire frequency range being measured.</p> <p>In the default settings (SENSE:IM:FREQUENCY:SPAN 20 MHz; SENSE:IM:BANDWIDTH BWIDTH[:RESOLUTION] 140 kHz), there are 345 numbers.</p>
2 W-CDMA mode	<p>Returns a series of floating point numbers that represent the frequency-domain spectrum trace for the entire frequency range being measured.</p> <p>In the default settings (SENSE:IM:FREQUENCY:SPAN 50 MHz; SENSE:IM:BANDWIDTH BWIDTH[:RESOLUTION] 140 kHz), there are 872 numbers.</p>

n	Results Returned
3	<p>Returns 2 scalar values of the measured mode determined by the Auto algorithm.</p> <ol style="list-style-type: none">1. Measurement Mode:<ol style="list-style-type: none">1: Two-tone2: Transmit IM3: Auto (Two-tone)4: Auto (Transmit IM)5: Unknown2. Reference:<ol style="list-style-type: none">1: Lower2: Upper3: Average4: Auto (Lower)5: Auto (Upper)

Occupied Bandwidth Measurement

This measures the bandwidth of the carrier signal in the occupied part of the channel. You must be in the PDC, iDEN (E4406A only), cdma2000, W-CDMA, or 1xEV-DO mode to use these commands. Use INSTRument:SElect to set the mode.

The general functionality of CONFigure, FETCh, MEASure, and READ are described at the beginning of this section. See the SENSE:OBW commands for more measurement related commands.

:CONFigure:OBW

:INITiate:OBW

:FETCh:OBW [n] ?

:READ:OBW [n] ?

:MEASure:OBW [n] ?

History: E4406A:
Version A.02.00 or later

Front Panel

Access: **Measure, Occupied BW**

After the measurement is selected, press **Restore Meas Defaults** to restore factory defaults.

Measurement results available

n	Results Returned
0	Returns unprocessed I/Q trace data, as a data array of trace point values, in volts.
1 (default) PDC, cdma2000, W-CDMA mode	Returns 2 scalar results, in the following order: 1. Occupied bandwidth - Hz 2. Absolute Carrier Power - dBm
1 (default) 1xEV-DO mode	Returns 2 scalar results, in the following order: 1. Occupied bandwidth - Hz 2. Absolute Carrier Power - dBm 3. Span - Hz 4. Spectrum Trace Points - points 5. Res BW - Hz

n	Results Returned
1 (default) iDEN mode E4406A	Returns the following 7 scalar results, in order. <ol style="list-style-type: none"> 1. Absolute power of occupied bandwidth (dBm) 2. Relative power of occupied bandwidth (dB) 3. Bandwidth for specified power percentage 4. Power percentage 5. Measured carrier frequency 6. Frequency span 7. Average count
2 PDC, cdma2000, W-CDMA, 1xEV-DO mode	Returns the frequency-domain spectrum trace (data array) for the entire frequency range being measured.
2, spectrum display only iDEN mode E4406A	Returns the frequency-domain spectrum trace (data array) for the entire frequency range (9003 points) being measured.

Power Statistics CCDF Measurement

For E4406A this is a statistical power measurement of the complementary cumulative distribution function (CCDF). You must be in the Basic, cdma2000, W-CDMA, or 1xEV-DO mode to use these commands. Use INSTRument:SElect to set the mode.

For PSA this is a statistical power measurement of the complementary cumulative distribution function (CCDF). You must be in the cdma2000, W-CDMA, or 1xEV-DO mode to use these commands. Use INSTRument:SElect to set the mode.

The general functionality of CONFIGure, FETCh, MEASure, and READ are described at the beginning of this section. See the SENSE:PStat commands for more measurement related commands.

:CONFigure:PStatistic

:INITiate:PStatistic

:FETCh:PStatistic [n] ?

:READ:PStatatistic [n] ?

:MEASure:PStatatistic [n] ?

History: Version A.03.00 or later, added in Basic A.04.00

Front Panel

Access: **Measure, Power Stat CCDF**

After the measurement is selected, press **Restore Meas Defaults** to restore factory defaults.

Measurement Results Available

n	Results Returned
0	Returns unprocessed I/Q trace data, as a series of trace point values, in volts. The I values are listed first in each pair, using the 0 through even-indexed values. The Q values are the odd-indexed values,
n=1 (or not specified)	Returns 10 scalar results: <ol style="list-style-type: none"> 1. Average input power (in dBm) 2. Probability at the average input power level (in %) 3. Power level that has 10% of the power 4. Power level that has 1% of the power 5. Power level that has 0.1% of the power 6. Power level that has 0.01% of the power 7. Power level that has 0.001% of the power 8. Power level that has 0.0001% of the power 9. Peak power (in dB) 10. Count

n	Results Returned
2	<p>Returns a series of 5001 floating point numbers (in percent) that represent the current measured power stat trace. This is the probability at particular power levels (average power), in the following order:</p> <ol style="list-style-type: none"> 1. Probability at 0.0 dB power 2. Probability at 0.01 dB power 3. Probability at 0.02 dB power <p style="text-align: center;">. . .</p> <ol style="list-style-type: none"> 1. Probability at 49.9 dB power 2. Probability at 50.0 dB power
3	<p>Returns a series of 5001 floating point numbers (in percent) that represent the Gaussian trace. This is the probability at particular power levels (average power), in the following order:</p> <ol style="list-style-type: none"> 1. Probability at 0.0 dB power 2. Probability at 0.01 dB power 3. Probability at 0.02 dB power <p style="text-align: center;">. . .</p> <ol style="list-style-type: none"> 1. Probability at 49.9 dB power 2. Probability at 50.0 dB power
4	<p>Returns a series of 5001 floating point numbers (in percent) that represent the user-definable reference trace. This is the probability at particular power levels (average power), in the following order:</p> <ol style="list-style-type: none"> 1. Probability at 0.0 dB power 2. Probability at 0.01 dB power 3. Probability at 0.02 dB power <p style="text-align: center;">. . .</p> <ol style="list-style-type: none"> 1. Probability at 49.9 dB power 2. Probability at 50.0 dB power

Power vs. Time Measurement

For E4406A this measures the average power during the “useful part” of the burst comparing the power ramp to required timing mask. You must be in EDGE, GSM, 1xEV-DO or Service mode to use these commands. Use INSTRument:SElect to set the mode.

For PSA this measures the average power during the “useful part” of the burst comparing the power ramp to required timing mask. You must be in GSM(w/EDGE), or 1xEV-DO mode to use these commands. Use INSTRument:SElect to set the mode.

The general functionality of CONFigure, FETCh, MEASure, and READ are described at the beginning of this section. See the SENSE:PVTime commands for more measurement related commands.

```
:CONFigure:PVTime
:INITiate:PVTime
:FETCh:PVTime [n] ?
:READ:PVTime [n] ?
:MEASure:PVTime [n] ?
```

Front Panel

Access: **Measure, Power vs Time**

After the measurement is selected, press **Restore Meas Defaults** to restore factory defaults.

History: Modified in version A.05.00..

Measurement Results Available

n	Results Returned
0	Returns unprocessed I/Q trace data, as a series of trace point values, in volts. The I values are listed first in each pair, using the 0 through even-indexed values. The Q values are the odd-indexed values.

n	Results Returned
n=1 (or not specified)	<p>Returns the following scalar results:</p> <ol style="list-style-type: none"> 1. Sample time is a floating point number that represents the time between samples when using the trace queries (n=0,2,etc.). 2. Power of single burst is the mean power (in dBm) across the useful part of the selected burst in the most recently acquired data, or in the last data acquired at the end of a set of averages. If averaging is on, the power is for the last burst. 3. Power averaged is the power (in dBm) of N averaged bursts, if averaging is on. The power is averaged across the useful part of the burst. Average <i>m</i> is a single burst from the acquired trace. If there are multiple bursts in the acquired trace, only one burst is used for average <i>m</i>. This means that N traces are acquired to make the complete average. If averaging is off, the value of power averaged is the same as the power single burst value. 4. Number of samples is the number of data points in the captured signal. This number is useful when performing a query on the signal (i.e. when n=0,2,etc.). 5. Start point of the useful part of the burst is the index of the data point at the start of the useful part of the burst 6. Stop point of the useful part of the burst is the index of the data point at the end of the useful part of the burst 7. Index of the data point where T_0 occurred. 8. Burst width of the useful part of the burst is the width of the burst measured at -3dB below the mean power in the useful part of the burst. 9. Maximum value is the maximum value of the most recently acquired data (in dBm). 10. Minimum value is the minimum value of the most recently acquired data (in dBm). 11. Burst search threshold is the value (in dBm) of the threshold where a valid burst is identified, after the data has been acquired. 12. IQ point delta is the number of data points offset that are internally applied to the useful data in traces <i>n</i>=2,3,4. You must apply this correction value to find the actual location of the Start, Stop, or T_0 values.

n	Results Returned
<p>n=1 (or not specified) 1xEV-DO or W-CDMA mode</p>	<p>Returns the following scalar results:</p> <ol style="list-style-type: none"> 1. Sample time is a floating point number that represents the time between samples when using the trace queries (where n = 0, 2, etc.). 2. Power of single burst is the mean power (in dBm) across the useful part of the selected burst in the most recently acquired data, or in the last data acquired at the end of a set of averages. If averaging is on, the power is for the last burst. 3. Power averaged is the power (in dBm) of N averaged bursts, if averaging is on. The power is averaged across the useful part of the burst. Average <i>m</i> is a single burst from the acquired trace. If there are multiple bursts in the acquired trace, only one burst is used for average <i>m</i>. This means that N traces are acquired to make the complete average. If averaging is off, the value of power averaged is the same as the power single burst value. 4. Number of samples (N) is the number of data points in the captured signal. This number is useful when performing a query on the signal (i.e. when n = 0, 2, etc.). 5. Start point of the useful part of the burst is the index of the data point at the start of the useful part of the burst 6. Stop point of the useful part of the burst is the index of the data point at the end of the useful part of the burst 7. Index of the data point where T_0 occurred. 8. Burst width of the useful part of the burst is the width of the burst measured at -3dB below the mean power in the useful part of the burst. 9. Maximum value is the maximum value of the most recently acquired data (in dBm). 10. Minimum value is the minimum value of the most recently acquired data (in dBm). 11. Burst search threshold is the value (in dBm) of the threshold where a valid burst is identified, after the data has been acquired. 12. Averaged number (N) is used to average the measurement results. 13. First position in index to exceed the limit (N) is ? 14. Reserved for future use, returns -999.0. 15. Reserved for future use, returns -999.0. 16. Reserved for future use, returns -999.0. 17. Absolute power in the region A (dBm) 18. Absolute power in the region B (dBm) 19. Absolute power in the region C (dBm) 20. Absolute power in the region D (dBm) 21. Absolute power in the region E (dBm) 22. Relative power in the region A (dB) 23. Relative power in the region B (dB) 24. Relative power in the region C (dB) 25. Relative power in the region D (dB)

n	Results Returned
n=1 (or not specified) (cont.) 1xEV-DO or W-CDMA mode	26. Relative power in the region E (dB) 27. Maximum absolute power in the region A (dBm) 28. Maximum absolute power in the region B (dBm) 29. Maximum absolute power in the region C (dBm) 30. Maximum absolute power in the region D (dBm) 31. Maximum absolute power in the region E (dBm) 32. Maximum relative power in the region A (dB) 33. Maximum relative power in the region B (dB) 34. Maximum relative power in the region C (dB) 35. Maximum relative power in the region D (dB) 36. Maximum relative power in the region E (dB) 37. Minimum absolute power in the region A (dBm) 38. Minimum absolute power in the region B (dBm) 39. Minimum absolute power in the region C (dBm) 40. Minimum absolute power in the region D (dBm) 41. Minimum absolute power in the region E (dBm) 42. Minimum relative power in the region A (dB) 43. Minimum relative power in the region B (dB) 44. Minimum relative power in the region C (dB) 45. Minimum relative power in the region D (dB) 46. Minimum relative power in the region E (dB)
2	Returns trace point values of the entire captured I/Q trace data. These data points are floating point numbers representing the power of the signal (in dBm). There are N data points, where N is the number of samples . The period between the samples is defined by the sample time .
3	Returns data points representing the upper mask (in dBm).
4	Returns data points representing the lower mask (in dBm).
6 W-CDMA mode	Returns 5 comma-separated scalar values of the pass/fail (0.0=passed, or 1.0=failed) results determined by testing the upper mask.
7 W-CDMA mode	Returns 5 comma-separated scalar values of the pass/fail (0.0=passed, or 1.0=failed) results determined by testing the lower mask:
7 EDGE, GSM, Service mode (E4406A only) GSM (/EDGE) mode (PSA only)	Returns power level values for the 8 slots in the current frame (in dBm).

n	Results Returned
<p>n=10</p> <p>GSM(/EDGE) mode (PSA only)</p>	<p>Returns the following scalar results (all in floating point numbers):</p> <ol style="list-style-type: none"> 1. Sample time is a floating point number that represents the time between samples when using the trace queries (n=0,2,etc.). 2. Power single burst is the mean power (in dBm) across the useful part of the selected burst in the most recently acquired data, or in the last data acquired at the end of a set of averages. If averaging is on, the power is for the last burst. 3. Power averaged is the power (in dBm) of N averaged bursts, if averaging is on. The power is averaged across the useful part of the burst. Average <i>m</i> is a single burst from the acquired trace. If there are multiple bursts in the acquired trace, only one burst is used for average <i>m</i>. This means that N traces are acquired to make the complete average. If averaging is off, the value of power averaged is the same as the power single burst value. 4. Number of samples is the number of data points in the captured signal. This number is useful when performing a query on the signal (i.e. when n=0,2,etc.). 5. Start is the index of the data point at the start of the useful part of the burst 6. Stop is the index of the data point at the end of the useful part of the burst 7. T₀ is the index of the data point where <i>t₀</i> occurred 8. Burst width is the width of the burst measured at -3dB below the mean power in the useful part of the burst. 9. Maximum value is the maximum value of the most recently acquired data (in dBm). 10. Minimum value is the minimum value of the most recently acquired data (in dBm). 11. Burst search threshold is the value (in dBm) of the threshold where a valid burst is identified, after the data has been acquired. 12. IQ point delta is the number of data points offset that are internally applied to the useful data in traces n=2,3,4. You must apply this correction value to find the actual location of the Start, Stop, or T₀ values. (e.g. for n=2, Start (for the IQ trace data) = Start + IQ_point_delta) 13. Trigger to T0 time is the elapsed time interval between the trigger point and T0. The time of the trigger point is known and the T0 time is calculated by the demodulation algorithm. The difference is the elapsed Trigger to T0 time.

Modulation Accuracy (Rho) Measurement

This measures the modulation accuracy of the transmitter by checking the magnitude and phase error and the EVM (error vector magnitude). You must be in the cdmaOne, cdma2000, W-CDMA, or 1xEV-DO mode to use these commands. Use INSTRument:SElect to set the mode.

For 1xEV-DO: these commands will measure modulation accuracy on network access equipment (base transmitter stations). Use MEAS:TRHO to measure terminal transmitter modulation accuracy, after selecting mobile stations using SENSE:RADio:DEvIce MS.

The general functionality of CONFigure, FETCh, MEASure, and READ are described at the beginning of this section. See the SENSE:RHO commands for more measurement related commands.

```
:CONFigure:RHO
:INITiate:RHO
:FETCh:RHO [n] ?
:READ:RHO [n] ?
:MEASure:RHO [n] ?
```

Front Panel

Access: **Measure, Mod Accuracy (Rho)** for cdmaOne

Measure, Mod Accuracy (Composite Rho) for cdma2000, 1xEV-DO, or W-CDMA (3GPP)

After the measurement is selected, press **Restore Meas Defaults** to restore factory defaults.

Measurement Results Available

n	Results Returned
0 cdmaOne mode	Returns unprocessed I/Q trace data, as a series of trace point values. The I values are listed first in each pair, using the 0 through even-indexed values. The Q values are the odd-indexed values. The standard sample rate is 7.5 MHz and the trace length is determined by the current measurement interval.
0 cdma2000 or W-CDMA mode	Returns unprocessed I/Q trace data, as a series of trace point values. The I values are listed first in each pair, using the 0 through even-indexed values. The Q values are the odd-indexed values.

n	Results Returned
<p>n=1 (or not specified) cdmaOne mode</p>	<p>Returns 7 floating point numbers, in the following order:</p> <ol style="list-style-type: none"> 1. Rho (no units) represents the correlation of the measured power compared to the ideal pilot channel. The calculation is performed after the complementary filter, so it is IS95 compliant. It is performed at the decision points in the pilot waveform. If averaging is on, this is the average of the individual rms measurements. 2. Time offset (with units of seconds) is the time delay of the even second clock with respect to the start of the short code PN sequences, at offsets from the 15 zeros in the characteristic phase of the sequence. 3. Frequency error of the measured signal, with units of Hz. This is based on the linear best fit of the uncorrected measured phase. 4. Carrier feedthrough has units of dB and is the dc error offset of I and Q, from the origin. 5. EVM has units of percent. The calculation is based on the composite of the phase error and magnitude error, between the measured signal and the ideal pilot channel. It is performed after the complementary filter which removes the inter-symbol interference in the modulated data. If averaging is on, this is the average of the individual rms measurements. 6. Magnitude error (with units of percent) is the rms error between the measured (compensated) magnitude and the ideal magnitude. This is performed after the complementary filter which removes the inter-symbol interference in the modulated data. If averaging is on, this is the average of the individual rms measurements. 7. Phase error (with units in percent) is the rms phase error between the measured phase and the ideal phase. The calculation is performed after the complementary filter which removes the inter-symbol interference in the modulated data. If averaging is on, this is the average of the individual rms measurements.

n	Results Returned
n=1 (or not specified) cdma2000	<p>Returns 11 scalar results, in the following order.</p> <ol style="list-style-type: none"> 1. RMS EVM is a floating point number (in percent) of EVM over the entire measurement area 2. Peak EVM is a floating point number (in percent) of peak EVM in the measurement area 3. Magnitude error is a floating point number (in percent) of average magnitude error over the entire measurement area 4. Phase error is a floating point number (in degree) of average phase error over the entire measurement area 5. I/Q origin offset is a floating point number (in dB) of the I and Q error (magnitude squared) offset from the origin 6. Frequency error is a floating point number (in Hz) of the frequency error in the measured signal 7. Rho is a floating point number of Rho 8. Peak code domain error is a floating point number (in dB) of the Peak Code Domain Error relative to the mean power 9. Peak code domain error channel number is the channel number in which the peak code domain error is detected at the max spreading factor. 10. Number of active channels. 11. Time offset is a floating point number (in second) PN offset from the trigger point.

n	Results Returned
<p>n=1 (or not specified) W-CDMA mode</p>	<p>Returns following 13 scalar results, in the following order.</p> <ol style="list-style-type: none"> 1. RMS EVM is a floating point number (in percent) of EVM over the entire measurement area 2. Peak EVM error is a floating point number (in percent) of peak EVM in the measurement area 3. Magnitude error is a floating point number (in percent) of average magnitude error over the entire measurement area 4. Phase error is a floating point number (in degree) of average phase error over the entire measurement area 5. I/Q origin offset is a floating point number (in dB) of the I and Q error (magnitude squared) offset from the origin 6. Frequency error is a floating point number (in Hz) of the frequency error in the measured signal 7. Rho is a floating point number of Rho 8. Peak Code Domain Error is a floating point number (in dB) of the Peak Code Domain Error relative to the mean power 9. Peak Code Domain Error Channel Number is the channel number in which the peak code domain error is detected at the max spreading factor. 10. Number of active channels. 11. Time offset is a floating point number (in chip) of the pilot phase timing from the acquisition trigger point. 12. CPICH power over a slot is a floating point number in dB of CPICH power over a measurement slot. In the MS mode the value returned is -999. 13. Average total power over a slot is a floating point number in dB of total RF power over a measurement slot. In the MS mode the value returned is -999.

n	Results Returned
<p>n=1 (or not specified)</p> <p>1xEV-DO mode</p> <p>For base stations: SENS:RAD:DEV BTS</p> <p>For meas type: CALC:RHO:TYPE DATA MAC PILOt PREamble</p>	<p>Returns up to the following 31 comma-separated scalar results, in the following order:</p> <p>Returns ONLY the following 9 comma-separated scalar results, in the following order, for base transmitter station measurements when the type is <i>NOT</i> set to ALL:</p> <ol style="list-style-type: none"> 1. RMS EVM – a floating point number (in percent) of EVM over the entire measurement area. 2. Peak EVM error – a floating point number (in percent) of peak EVM in the measurement area. 3. Magnitude error – a floating point number (in percent) of average magnitude error over the entire measurement area. 4. Phase error – a floating point number (in degree) of average phase error over the entire measurement area. 5. I/Q Origin Offset – a floating point number (in dB) of the I and Q error (magnitude squared) offset from the origin. 6. Frequency error – a floating point number (in Hz) of the frequency error in the measured signal. 7. Rho – a floating point number of Rho. 8. Number of active channels. 9. Time offset is the time from the trigger to the PN offset – a floating point number (in micro seconds) of PN offset from the trigger point.

n	Results Returned
<p>n=1 (or not specified)</p> <p>1xEV-DO mode</p> <p>For base stations: SENS:RAD:DEV BTS</p> <p>For meas type ALL: CALC:RHO:TYPE ALL</p>	<p>Returns the following 17 scalar results for base transmitter station measurements when the type is set to ALL.</p> <p>Rho Overall-1 and Rho Overall-2 specified in 3GPP2 TSG-C4.1 Recommended Minimum Performance Standard for cdma2000 High Rate Data Packet Access Network, 11.4.2 Waveform Quality Measurement section.</p> <ol style="list-style-type: none"> 10. RMS EVM (Overall-1) – a floating point number (in percent) of EVM over the entire measurement area. 11. Peak EVM error (Overall-1) – a floating point number (in percent) of peak EVM in the measurement area. 12. Magnitude error (Overall-1) – a floating point number (in percent) of average magnitude error over the entire measurement area. 13. Phase error (Overall-1) – a floating point number (in degree) of average phase error over the entire measurement area. 14. I/Q Origin Offset (Overall-1) – a floating point number (in dB) of the I and Q error (magnitude squared) offset from the origin. 15. Frequency error (Overall-1) – a floating point number (in Hz) of the frequency error in the measured signal. 16. Rho (Overall-1) – a floating point number of Rho. 17. RMS EVM (Overall-2) – a floating point number (in percent) of EVM over the entire measurement area. 18. Peak EVM error (Overall-2) – a floating point number (in percent) of peak EVM in the measurement area. 19. Magnitude error (Overall-2) – a floating point number (in percent) of average magnitude error over the entire measurement area. 20. Phase error (Overall-2) – a floating point number (in degree) of average phase error over the entire measurement area. 21. I/Q Origin Offset (Overall-2) – a floating point number (in dB) of the I and Q error (magnitude squared) offset from the origin. 22. Frequency error (Overall-2) – a floating point number (in Hz) of the frequency error in the measured signal. 23. Rho (Overall-2) – a floating point number of Rho. 24. Number of active channels in Pilot 25. Number of active channels in Mac 26. Number of active channels in Data 27. Preamble Length 28. MAC Index 29. Number of Max MAC Inactive channel Power – a floating point number (in dB) of Maximum MAC Inactive Channel Power channels in Data 30. Max Data Active Channel Power – a floating point number (in dB) of Maximum Data Active Channel Power 31. Min Data Active Channel Power – a floating point number (in dB) of Minimum Data Active Channel Power

n	Results Returned
2 cdmaOne mode	EVM trace – returns error vector magnitude (EVM) data, as trace point values in percent. The first value is the chip 0 decision point. The trace is interpolated for the currently selected points/chips displayed on the front panel. The number of trace points depends on the current measurement interval setting.
2 cdma2000 or W-CDMA mode	EVM trace – returns series of floating point numbers (in percent) that represent each sample in the EVM trace. The first number is the symbol 0 decision point. There are X points per symbol ($X = \text{points/chip}$). Therefore, the decision points are at $0, 1 \times X, 2 \times X, 3 \times X \dots$
2 1xEV-DO mode	Returns series of floating point numbers (in percent) that represent each sample in the EVM trace. The first number is the symbol 0 decision point and there are X points per symbol. Therefore, the decision points are at $0, 1xX, 2xX, 3xX\dots$ ($X = \text{the number of points per chip}$) This traces is available when the Measurement Channel Type Selection is Pilot, MAC or Data (CALCulate:RHO:TYPE = PILot MAC DATA) In all cases, returns one full slot data points, but only portion of EVM computation is performed are valid. All other portion is 0.0
3 cdmaOne mode	Magnitude error trace – returns magnitude error data, as trace point values, in percent. The first value is the chip 0 decision point. The trace is interpolated for the currently selected points/chips displayed on the front panel. The number of trace points depends on the current measurement interval setting.
3 cdma2000, W-CDMA, or 1xEV-DO mode	Magnitude error trace – returns series of floating point numbers (in percent) that represent each sample in the magnitude error trace. The first number is the symbol 0 decision point. There are X points per symbol ($X = \text{points/chip}$). Therefore, the decision points are at $0, 1 \times X, 2 \times X, 3 \times X \dots$ For 1xEV-DO: this traces is available when the Measurement Channel Type Selection is Pilot, MAC or Data (CALCulate:RHO:TYPE = PILot MAC DATA) In all cases, returns one full slot data points, but only portion of EVM computation is performed are valid. All other portion is 0.0
4 cdmaOne mode	Phase error trace – returns phase error data, as trace point values, in degrees. The first value is the symbol 0 decision point. The trace is interpolated for the currently selected chips/symbol displayed on the front panel. The number of trace points depends on the current measurement interval setting.

n	Results Returned
4 cdma2000, W-CDMA, or 1xEV-DO mode	<p>Phase error trace – returns series of floating point numbers (in degrees) that represent each sample in the phase error trace. There are X points per symbol ($X = \text{points}/\text{chip}$). Therefore, the decision points are at $0, 1 \times X, 2 \times X, 3 \times X \dots$</p> <p>For 1xEV-DO: this traces is available when the Measurement Channel Type Selection is Pilot, MAC or Data (CALCulate:RHO:TYPE = PILOt MAC DATA) In all cases, returns one full slot data points, but only portion of EVM computation is performed are valid. All other portion is 0.0</p>
5 cdmaOne mode	<p>Corrected measured data – returns a series of floating point numbers that alternately represent I and Q pairs of the corrected measured trace data. The magnitude of each I and Q pair are normalized to 1.0.</p> <p>The number of trace points depends on the current measurement interval setting.</p> <p>The numbers are sent in the following order:</p> <p style="padding-left: 40px;">In-phase (I) sample, of symbol 0 decision point Quadrature-phase (Q) sample, of symbol 0 decision point ... In-phase (I) sample, of symbol 1 decision point Quadrature-phase (Q) sample, of symbol 1 decision point ...</p> <p>The trace can be interpolated to 2,4, 8 points/chip selected with the display Points/Chip softkey. This will change the number of points between decision points in the trace, changing the number of I/Q pairs sent for each decision point.</p>
5 cdma2000, W-CDMA, 1xEV-DO mode	<p>Corrected measured trace – returns series of floating point numbers that alternately represent I and Q pairs of the corrected measured trace. The magnitude of each I and Q pair are normalized to 1.0. The first number is the in-phase (I) sample of symbol 0 decision point and the second is the quadrature-phase (Q) sample of symbol 0 decision point. There are X points per symbol ($X = \text{points}/\text{chip}$), so the series of numbers is:</p> <p style="padding-left: 40px;">1st number = I of the symbol 0 decision point 2nd number = Q of the symbol 0 decision point ... ($2 \times X + 1$), number = I of the symbol 1 decision point ($2 \times X + 2$), number = Q of the symbol 1 decision point ... ($2 \times X \times Nth + 1$) number = I of the symbol N decision point ($2 \times X \times Nth + 2$) number = Q of the symbol N decision point</p> <p>For 1xEV-DO: this traces is available when the Measurement Channel Type Selection is Pilot, MAC or Data (CALCulate:RHO:TYPE = PILOt MAC DATA) In all cases, returns one full slot data points, but only portion of EVM computation is performed are valid. All other portion is 0.0</p>

n	Results Returned
6 cdmaOne mode	<p>Reference IQ data – returns a series of floating point numbers that alternately represent I and Q pairs of the reference trace data.</p> <p>The number of trace points depends on the current measurement interval and points per chip settings.</p> <p>The numbers are sent in the following order:</p> <p style="padding-left: 40px;">In-phase (I) sample, of symbol 0 decision point Quadrature-phase (Q) sample, of symbol 0 decision point ... In-phase (I) sample, of symbol 1 decision point Quadrature-phase (Q) sample, of symbol 1 decision point ...</p> <p>The trace can be interpolated to 2,4,8 points/chip selected with the display Points/Chip softkey.</p>
6 cdma2000 mode	<p>Returns 6 scalar values of the pass/fail (0=passed, or 1=failed) results determined by testing the EVM and peak EVM.</p> <ol style="list-style-type: none"> 1. Test result of EVM 2. Test result of Peak EVM 3. Test result of Rho 4. Test result of Peak Code Domain Error 5. Test result of Time Offset 6. Test result of Phase Error
6 1xEV-DO mode	<p>The same as n=2. (Overall-1)</p> <p>This trace is available when the Measurement Channel Type Selection is All (CALCulate:RHO:TYPE = ALL)</p> <p>(Rho Overall-1 and Rho Overall-2 as specified in 3GPP2 TSG-C4.1 Recommended Minimum Performance Standard for cdma2000 High Rate Data Packet Access Network, 11.4.2 Waveform Quality Measurement section.)</p> <p>n=6, 7, 8, 9 are for Overall-1 data trace n=10, 11, 12, 13 are for Overall-2 data trace</p> <p>In all cases, returns one full slot data points, but only portion of EVM computation is performed are valid. All other portion is 0.0</p>
6 W-CDMA mode	<p>Returns 6 comma-separated scalar values of the pass/fail (0.0 = passed, or 1.0 = failed) results determined by testing the EVM and peak EVM.</p> <ol style="list-style-type: none"> 1. Test result of EVM 2. Test result of Peak EVM 3. Test result of Rho 4. Test result of Peak Code Domain Error 5. Test result of Frequency Error 6. Test result of CPICH power over a frame (If MS is selected, this always returns 0.0.)

n	Results Returned
7 cdmaOne mode	<p>complementary filtered measured data – returns a series of floating point numbers that alternately represent I and Q pairs of the complementary filtered measured data. This is inverse filtered data of the inter-symbol interference in CDMA signals due to the digital transmission filters defined in the standard as well as the base station phase equalization filter.</p> <p>The number of trace points depends on the current measurement interval setting.</p> <p>The numbers are sent in the following order:</p> <p style="padding-left: 40px;">In-phase (I) sample, of symbol 0 decision point Quadrature-phase (Q) sample, of symbol 0 decision point ... In-phase (I) sample, of symbol 1 decision point Quadrature-phase (Q) sample, of symbol 1 decision point ...</p> <p>The trace can be interpolated to 2,4,8 points/chip selected with the display Points/Chip softkey. This will change the number of points between decision points in the trace, changing the number of I/Q pairs sent for each decision point.</p>
7 cdma2000 mode	<p>Returns series of floating point numbers of code level, code index, power (in dB), time offset (in ns), phase offset (in rad), and code domain error (in dB). The total number of results are six times of “number of active channels”. The number of active channels can be obtained by the 10th result of FETCH:RHO0 command.</p>
7 1xEV-DO mode	<p>The same as n=3. (Overall-1)</p> <p>This trace is available when the Measurement Channel Type Selection is All (CALCulate:RHO:TYPE = ALL)</p> <p>(Rho Overall-1 and Rho Overall-2 as specified in 3GPP2 TSG-C4.1 Recommended Minimum Performance Standard for cdma2000 High Rate Data Packet Access Network, 11.4.2 Waveform Quality Measurement section.)</p> <p>n=6, 7, 8, 9 are for Overall-1 data trace n=10, 11, 12, 13 are for Overall-2 data trace</p> <p>In all cases, returns one full slot data points, but only portion of EVM computation is performed are valid. All other portion is 0.0</p>

n	Results Returned
7 W-CDMA mode	<p>With a device of BTS, it returns a series of floating point numbers: symbol rate (ex. 7.5 ksps), OVVSF code number, a dummy value, power level and code domain error for the active channels.</p> <p>With a device of MS, it returns a series of floating point numbers: symbol rate (ex. 15 ksps), OVVSF code number, 1.0 (I) or -1.0 (Q), power level and code domain error for the active channels. The results would look like the following:</p> <p>1st number = Symbol Rate for 1st Active Channel 2nd number = OVVSF Code number for 1st Active Channel 3rd number = (in BTS) -999, or (in MS) either -1 (I) or +1 (Q) for 1st Active Channel 4th number = Power Level (in dB) for 1st Active Channel 5th number = Code Domain Error for 1st Active Channel ... (N-1)*5+1 number = Symbol Rate for Nth Active Channel (N-1)*5+2 number = OVVSF Code number for Nth Active Channel (N-1)*5+3 number = -999 (in BTS), or either -1 (I) or +1 (Q) (in MS) for Nth Active Channel (N-1)*5+4 number = Power Level (in dB) for Nth Active Channel N*5 number = Code Domain Error for Nth Active Channel</p> <p>Number of active channel is given by 10th parameter of :MEASure:RHO[1].</p>
8 cdmaOne mode	<p>complementary filtered reference data – returns a series of floating point numbers that alternately represent I and Q pairs of the complementary filtered reference data. This is inverse filtered data of the inter-symbol interference in CDMA signals due to the digital transmission filters defined in the standard as well as the base station phase equalization filter.</p> <p>The number of trace points depends on the current measurement interval setting.</p> <p>The numbers are sent in the following order:</p> <p>In-phase (I) sample, of symbol 0 decision point Quadrature-phase (Q) sample, of symbol 0 decision point ... In-phase (I) sample, of symbol 1 decision point Quadrature-phase (Q) sample, of symbol 1 decision point ...</p> <p>The trace can be interpolated to 2,4,8 points/chip selected with the display Points/Chip softkey. This will change the number of points between decision points in the trace, changing the number of I/Q pairs sent for each decision point.</p>

n	Results Returned
<p>8 W-CDMA mode</p>	<p>Returns a series of floating point numbers (in dB) that represents all the code domain powers.</p> <p>With a device of BTS, there are 512 numbers. If the active channel occupies more than the max spreading factor (7.5 ksps) the power is duplicated (active symbol rate/7.5 ksps) times.</p> <p>1st number = 1st code power over the slot 2nd number = 2nd code power over the slot ... Nth number = Nth code power over the slot</p> <p>With a device of MS, there are 256 I/Q pairs. If the active channel occupies more than the max spreading factor (15 ksps) the power is duplicated (active symbol rate / 15 ksps) times.</p> <p>1st number = 1st in-phase code power over the slot 2nd number = 1st quad-phase code power over the slot ... (2*N-1) number = Nth in-phase code power over the slot (2 *N) number = Nth quad-phase code power over a slot</p> <p>N = the number of codes detected. The total number of codes varies because of the different symbol rates of each code.</p>
<p>8 1xEV-DO mode</p>	<p>The same as n=4. (Overall-1)</p> <p>This trace is available when the Measurement Channel Type Selection is All (CALCulate:RHO:TYPE = ALL)</p> <p>(Rho Overall-1 and Rho Overall-2 as specified in 3GPP2 TSG-C4.1 Recommended Minimum Performance Standard for cdma2000 High Rate Data Packet Access Network, 11.4.2 Waveform Quality Measurement section.)</p> <p>n=6, 7, 8, 9 are for Overall-1 data trace n=10, 11, 12, 13 are for Overall-2 data trace</p> <p>In all cases, returns one full slot data points, but only portion of EVM computation is performed are valid. All other portion is 0.0</p>

n	Results Returned
<p>9 1xEV-DO mode</p>	<p>The same as n=5. (Overall-1)</p> <p>This trace is available when the Measurement Channel Type Selection is All (CALCulate:RHO:TYPE = ALL)</p> <p>(Rho Overall-1 and Rho Overall-2 as specified in 3GPP2 TSG-C4.1 Recommended Minimum Performance Standard for cdma2000 High Rate Data Packet Access Network, 11.4.2 Waveform Quality Measurement section.)</p> <p>n=6, 7, 8, 9 are for Overall-1 data trace n=10, 11, 12, 13 are for Overall-2 data trace</p> <p>In all cases, returns one full slot data points, but only portion of EVM computation is performed are valid. All other portion is 0.0</p>
<p>10 1xEV-DO mode</p>	<p>The same as n=2. (Overall-2)</p> <p>This trace is available when the Measurement Channel Type Selection is All (CALCulate:RHO:TYPE = ALL)</p> <p>(Rho Overall-1 and Rho Overall-2 as specified in 3GPP2 TSG-C4.1 Recommended Minimum Performance Standard for cdma2000 High Rate Data Packet Access Network, 11.4.2 Waveform Quality Measurement section.)</p> <p>n=6, 7, 8, 9 are for Overall-1 data trace n=10, 11, 12, 13 are for Overall-2 data trace</p> <p>In all cases, returns one full slot data points, but only portion of EVM computation is performed are valid. All other portion is 0.0</p>
<p>11 cdmaOne mode</p>	<p>Corrected measured data – returns a series of floating point numbers that alternately represent I and Q pairs of the corrected measured trace data. The magnitude of each I and Q pair are normalized to 1.0.</p> <p>The number of trace points depends on the current setting for the number of displayed I/Q points in the I/Q display.</p> <p>The numbers are sent in the following order:</p> <p style="padding-left: 40px;">In-phase (I) sample, of symbol 0 decision point Quadrature-phase (Q) sample, of symbol 0 decision point ... In-phase (I) sample, of symbol 1 decision point Quadrature-phase (Q) sample, of symbol 1 decision point ...</p> <p>The trace can be interpolated to 2,4,8 points/chip selected with the display Points/Chip softkey. This will change the number of points between decision points in the trace, changing the number of I/Q pairs sent for each decision point.</p>

n	Results Returned
<p>11 1xEV-DO mode</p>	<p>The same as n=2. (Overall-2)</p> <p>This trace is available when the Measurement Channel Type Selection is All (CALCulate:RHO:TYPE = ALL)</p> <p>(Rho Overall-1 and Rho Overall-2 as specified in 3GPP2 TSG-C4.1 Recommended Minimum Performance Standard for cdma2000 High Rate Data Packet Access Network, 11.4.2 Waveform Quality Measurement section.)</p> <p>n=6, 7, 8, 9 are for Overall-1 data trace n=10, 11, 12, 13 are for Overall-2 data trace</p> <p>In all cases, returns one full slot data points, but only portion of EVM computation is performed are valid. All other portion is 0.0</p>
<p>12 1xEV-DO mode</p>	<p>The same as n=4. (Overall-2)</p> <p>This trace is available when the Measurement Channel Type Selection is All (CALCulate:RHO:TYPE = ALL)</p> <p>(Rho Overall-1 and Rho Overall-2 as specified in 3GPP2 TSG-C4.1 Recommended Minimum Performance Standard for cdma2000 High Rate Data Packet Access Network, 11.4.2 Waveform Quality Measurement section.)</p> <p>n=6, 7, 8, 9 are for Overall-1 data trace n=10, 11, 12, 13 are for Overall-2 data trace</p> <p>In all cases, returns one full slot data points, but only portion of EVM computation is performed are valid. All other portion is 0.0</p>

n	Results Returned
13 cdmaOne mode	<p>complementary filtered measured data – returns a series of floating point numbers that alternately represent I and Q pairs of the complementary filtered measured data. This is inverse filtered data of the inter-symbol interference in CDMA signals due to the digital transmission filters defined in the standard as well as the base station phase equalization filter.</p> <p>The number of trace points depends on the current setting for the number of displayed I/Q points in the I/Q display.</p> <p>The numbers are sent in the following order:</p> <p style="padding-left: 40px;">In-phase (I) sample, of symbol 0 decision point Quadrature-phase (Q) sample, of symbol 0 decision point ... In-phase (I) sample, of symbol 1 decision point Quadrature-phase (Q) sample, of symbol 1 decision point ...</p> <p>The trace can be interpolated to 2,4,8 points/chip selected with the display Points/Chip softkey. This will change the number of points between decision points in the trace, changing the number of I/Q pairs sent for each decision point.</p>
13 1xEV-DO mode	<p>The same as n=5. (Overall-2)</p> <p>This trace is available when the Measurement Channel Type Selection is All (CALCulate:RHO:TYPE = ALL)</p> <p>(Rho Overall-1 and Rho Overall-2 as specified in 3GPP2 TSG-C4.1 Recommended Minimum Performance Standard for cdma2000 High Rate Data Packet Access Network, 11.4.2 Waveform Quality Measurement section.)</p> <p>n=6, 7, 8, 9 are for Overall-1 data trace n=10, 11, 12, 13 are for Overall-2 data trace</p> <p>In all cases, returns one full slot data points, but only portion of EVM computation is performed are valid. All other portion is 0.0</p>

n	Results Returned
<p>14 1xEV-DO mode</p>	<p>The same as n=5. (Overall-2) I/Q trace data is descrambled.</p> <p>This trace is available when the Measurement Channel Type Selection is All (CALCulate:RHO:TYPE = ALL)</p> <p>(Rho Overall-1 and Rho Overall-2 as specified in 3GPP2 TSG-C4.1 Recommended Minimum Performance Standard for cdma2000 High Rate Data Packet Access Network, 11.4.2 Waveform Quality Measurement section.)</p> <p>n=6, 7, 8, 9 are for Overall-1 data trace n=10, 11, 12, 13 are for Overall-2 data trace</p> <p>In all cases, returns one full slot data points, but only portion of EVM computation is performed are valid. All other portion is 0.0</p>
<p>15 1xEV-DO mode</p>	<p>Returns 10 comma-separated scalar values of the pass/fail (0.0=passed, or 1.0=failed) results determined by testing the EVM, Peak EVM:</p> <ol style="list-style-type: none"> 1. Test result of EVM 2. Test result of Peak EVM 3. Test result of Rho 4. Test result of Frequency Error <p>Following Timing and Phase results are valid only Multichannel Estimator is On and existence of multiple codes. When the measurement is not valid, the results are 0.0</p> <ol style="list-style-type: none"> 5. Test result of Timing 6. Test result of Phase <p>Following Pilot Offset result is valid only external trigger is selected. When the measurement is not valid, the result is 0.0</p> <ol style="list-style-type: none"> 7. Test result of Pilot Offset <p>Following three results are valid exclusively. When the measurement is not valid, the result is 0.0</p> <ol style="list-style-type: none"> 8. Test result of Max MAC Inactive Channel Power 9. Test result of Max Data Active Channel Power 10. Test result of Min Data Active Channel Power

Spurious Emissions Measurement

This measures spurious emissions levels up to five pairs of offset/region frequencies and relates them to the carrier power. You must be in the cdma2000, W-CDMA or 1xEV-DO mode to use these commands. Use INSTRument:SElect to set the mode. For 1xEV-DO mode, this command will return spurious emissions measurements or adjacent channel power measurements, depending on which setting is selected using SENSE:SEMask:SEGment:TYPE ACPr|SEMask.

The general functionality of CONFigure, FETCh, MEASure, and READ are described at the beginning of this section. See the SENSE:SEMask commands for more measurement related commands.

```
:CONFigure:SEMask  
:INITiate:SEMask  
:FETCh:SEMask [n] ?  
:READ:SEMask [n] ?  
:MEASure:SEMask [n] ?
```

Front Panel

Access: **Measure, Spectrum Emission Mask**

After the measurement is selected, press **Restore Meas Defaults** to restore factory defaults.

Measurement Results Available

Measurement Type	n	Results Returned
	0	Returns unprocessed I/Q trace data, as a series of trace point values, in volts.

Measurement Type	n	Results Returned
Total power reference	n=1 (or not specified)	<p>Returns 60 scalar results, in the following order:</p> <ol style="list-style-type: none"> 1. Reserved for future use, returns –999.0 2. Absolute power at the center frequency (reference) area (dBm) 3. Reserved for future use, returns –999.0 4. Reserved for future use, returns –999.0 5. Peak frequency in the center frequency (reference) area (Hz) 6. Reserved for future use, returns –999.0 7. Reserved for future use, returns –999.0 8. Reserved for future use, returns –999.0 9. Reserved for future use, returns –999.0 10. Reserved for future use, returns –999.0 11. Relative power on the negative offset A (dBc) 12. Absolute power on the negative offset A (dBm) 13. Relative peak power on the negative offset A (dBc) 14. Absolute peak power on the negative offset A (dBm) 15. Peak frequency in the negative offset A (Hz) 16. Relative power on the positive offset A (dBc) 17. Absolute power on the positive offset A (dBm) 18. Relative peak power on the positive offset A (dBc) 19. Absolute peak power on the positive offset A (dBm) 20. Peak frequency in the positive offset A (Hz) 21. Relative power on the negative offset B (dBc) <p style="text-align: center;">. . .</p> <ol style="list-style-type: none"> 1. Absolute peak power on the positive offset E (dBm) 2. Peak frequency in the positive offset E (Hz) <p>When [:SENSe]:SEMask:SEGMENT is set to REGION, the positive offsets are not available and return –999.0.</p>

Measurement Type	n	Results Returned
Power spectral density reference	n=1 (or not specified)	<p>Returns 60 scalar results, in the following order:</p> <ol style="list-style-type: none"> 1. Reserved for future use, returns -999.0 2. Absolute power at the center frequency (reference) area (dBm) 3. Reserved for future use, returns -999.0 4. Reserved for future use, returns -999.0 5. Peak frequency in the center frequency (reference) area (Hz) 6. Reserved for future use, returns -999.0 7. Reserved for future use, returns -999.0 8. Reserved for future use, returns -999.0 9. Reserved for future use, returns -999.0 10. Reserved for future use, returns -999.0 11. Relative power on the negative offset A (dB) 12. Absolute power on the negative offset A (dBm/Hz) 13. Relative peak power on the negative offset A (dB) 14. Absolute peak power on the negative offset A (dBm/Hz) 15. Peak frequency in the negative offset A (Hz) 16. Relative power on the positive offset A (dB) 17. Absolute power on the positive offset A (dBm/Hz) 18. Relative peak power on the positive offset A (dB) 19. Absolute peak power on the positive offset A (dBm/Hz) 20. Peak frequency in the positive offset A (Hz) 21. Relative power on the negative offset B (dB) <p style="text-align: center;">. . .</p> <ol style="list-style-type: none"> 1. Absolute peak power on the positive offset E (dBm/Hz) 2. Peak frequency in the positive offset E (Hz) <p>When [:SENSE]:SEMask:SEGMENT is set to REGION, the positive offsets are not available and return -999.0.</p>
	2	Returns the displayed frequency domain spectrum trace data separated by comma. The number of data is 2001 when DISPLAY:SEMask:VIEW is set to ALL.
	3	Returns the displayed frequency domain absolute limit trace data separated by comma. The number of data is 2001 when DISPLAY:SEMask:VIEW is set to ALL.
	4	Returns the displayed frequency domain relative limit trace data separated by comma. The number of data is 2001 when DISPLAY:SEMask:VIEW is set to ALL.

Measurement Type	n	Results Returned
Total power reference	5	<p>Returns 12 scalar values (in dBm) of the absolute power of the segment frequencies:</p> <ol style="list-style-type: none"> 1. Total power reference (dBm), for cdma2000 and W-CDMA Reserved for future use, returns –999.0, for 1xEV-DO 2. Reserved for future use, returns –999.0 3. Negative offset frequency (A) or region (A) 4. Positive offset frequency (A) <p style="text-align: center;">. . .</p> <ol style="list-style-type: none"> 1. Negative offset frequency (E) or region (E) 2. Positive offset frequency (E) <p>When [:SENSE]:SEMAsk:SEGMENT is set to REGION, the positive offsets are not available and return –999.0.</p>
Power spectral density reference	5	<p>Returns 12 scalar values (in dBm/Hz) of the absolute power of the segment frequencies:</p> <ol style="list-style-type: none"> 1. Power spectral density reference (dBm/Hz), for cdma2000 and W-CDMA Reserved for future use, returns –999.0, for 1xEV-DO 2. Reserved for future use, returns –999.0 3. Negative offset frequency (A) or region (A) 4. Positive offset frequency (A) <p style="text-align: center;">. . .</p> <ol style="list-style-type: none"> 1. Negative offset frequency (E) or region (E) 2. Positive offset frequency (E) <p>When [:SENSE]:SEMAsk:SEGMENT is set to REGION, the positive offsets are not available and return –999.0.</p>
Total power reference	6	<p>Returns 12 scalar values (in dBc) of the power relative to the carrier at the segment frequencies:</p> <ol style="list-style-type: none"> 1. Reserved for future use, returns –999.0 2. Reserved for future use, returns –999.0 3. Negative offset frequency (A) or region (A) 4. Positive offset frequency (A) <p style="text-align: center;">. . .</p> <ol style="list-style-type: none"> 1. Negative offset frequency (E) or region (E) 2. Positive offset frequency (E) <p>When [:SENSE]:SEMAsk:SEGMENT is set to REGION, the positive offsets are not available and return –999.0.</p>

Measurement Type	n	Results Returned
Power spectral density reference	6	<p>Returns 12 scalar values (in dBc) of the power relative to the carrier at the segment frequencies:</p> <ol style="list-style-type: none"> 1. Reserved for future use, returns -999.0 2. Reserved for future use, returns -999.0 3. Negative offset frequency (A) or region (A) 4. Positive offset frequency (A) <p>...</p> <ol style="list-style-type: none"> 1. Negative offset frequency (E) or region (E) 2. Positive offset frequency (E) <p>When [:SENSe]:SEMask:SEGMENT is set to REGION, the positive offsets are not available and return -999.0.</p>
	7	<p>Returns 12 pass/fail test results (0 = passed, or 1 = failed) determined by testing the absolute power of the segment frequencies:</p> <ol style="list-style-type: none"> 1. Reserved for future use, returns -999.0 2. Reserved for future use, returns -999.0 3. Negative offset frequency (A) or region (A) 4. Positive offset frequency (A) <p>...</p> <ol style="list-style-type: none"> 1. Negative offset frequency (E) or region (E) 2. Positive offset frequency (E) <p>When [:SENSe]:SEMask:SEGMENT is set to REGION, the positive offsets are not available and return -999.0.</p>
	8	<p>Returns 12 scalar values of the pass/fail (0=passed, or 1=failed) results determined by testing the power relative to the segment frequencies:</p> <ol style="list-style-type: none"> 1. Reserved for future use, returns -999.0 2. Reserved for future use, returns -999.0 3. Negative offset frequency (A) or region (A) 4. Positive offset frequency (A) <p>...</p> <ol style="list-style-type: none"> 1. Negative offset frequency (E) or region (E) 2. Positive offset frequency (E) <p>When [:SENSe]:SEMask:SEGMENT is set to REGION, the positive offsets are not available and return -999.0.</p>

Measurement Type	n	Results Returned
	9	<p>Returns 12 scalar values of frequency (in Hz) that have peak power in each offset/region:</p> <ol style="list-style-type: none"> 1. Reserved for future use, returns –999.0 2. Reserved for future use, returns –999.0 3. Negative offset frequency (A) or region (A) 4. Positive offset frequency (A) <p style="text-align: center;">. . .</p> <ol style="list-style-type: none"> 1. Negative offset frequency (E) or region (E) 2. Positive offset frequency (E) <p>When [:SENSE]:SEMAsk:SEGMENT is set to REGION, the positive offsets are not available and return –999.0.</p>
	10	<p>Returns 12 scalar values (in dBm) of the absolute peak power of the segment frequencies:</p> <ol style="list-style-type: none"> 1. Reserved for future use, returns –999.0 2. Reserved for future use, returns –999.0 3. Negative offset frequency (A) or region (A) 4. Positive offset frequency (A) <p style="text-align: center;">. . .</p> <ol style="list-style-type: none"> 1. Negative offset frequency (E) or region (E) 2. Positive offset frequency (E) <p>When [:SENSE]:SEMAsk:SEGMENT is set to REGION, the positive offsets are not available and return –999.0.</p>
	11	<p>Returns 12 scalar values (in dBc) of the peak power relative to the carrier at the segment frequencies:</p> <ol style="list-style-type: none"> 1. Reserved for future use, returns –999.0 2. Reserved for future use, returns –999.0 3. Negative offset frequency (A) or region (A) 4. Positive offset frequency (A) <p style="text-align: center;">. . .</p> <ol style="list-style-type: none"> 1. Negative offset frequency (E) or region (E) 2. Positive offset frequency (E) <p>When [:SENSE]:SEMAsk:SEGMENT is set to REGION, the positive offsets are not available and return –999.0.</p>

Spectrum (Frequency Domain) Measurement

For E4406A this measures the amplitude of your input signal with respect to the frequency. It provides spectrum analysis capability using FFT (fast Fourier transform) measurement techniques. You must select the appropriate mode using INSTRument:SElect, to use these commands.

For PSA this measures the amplitude of your input signal with respect to the frequency. It provides spectrum analysis capability using FFT (fast Fourier transform) measurement techniques. You must be in the Basic, cdmaOne, cdma2000, 1xEV-DO, W-CDMA, GSM (w/EDGE), NADC, or PDC mode to use these commands. Use INSTRument:SElect, to select the mode.

The general functionality of CONFigure, FETCh, MEASure, and READ are described at the beginning of this section. See the SENSE:SPECTrum commands for more measurement related commands.

```
:CONFigure:SPECTrum
:INITiate:SPECTrum
:FETCh:SPECTrum[n]?
:READ:SPECTrum[n]?
:MEASure:SPECTrum[n]?
```

Front Panel

Access: **Measure, Spectrum (Freq Domain)**

After the measurement is selected, press **Restore Meas Defaults** to restore factory defaults.

Measurement Results Available

n	Results Returned
0	Returns unprocessed I/Q trace data, as a series of trace point values, in volts. The I values are listed first in each pair, using the 0 through even-indexed values. The Q values are the odd-indexed values.

n	Results Returned
n=1 (or not specified)	<p>Returns the following scalar results:</p> <ol style="list-style-type: none"> 1. FFT peak is the FFT peak amplitude. 2. FFT frequency is the FFT frequency of the peak amplitude. 3. FFT points is the Number of points in the FFT spectrum. 4. First FFT frequency is the frequency of the first FFT point of the spectrum. 5. FFT spacing is the frequency spacing between the FFT points of the spectrum. 6. Time domain points is the number of points in the time domain trace used for the FFT. The number of points doubles if the data is complex instead of real. See the time domain scaler description below. 7. First time point is the time of the first time domain point, where time zero is the trigger event. 8. Time spacing is the time spacing between the time domain points. The time spacing value doubles if the data is complex instead of real. See the time domain scaler description below. 9. Time domain returns a 1 if time domain is complex (I/Q) and complex data will be returned. It returns a 0 if the data is real. (raw ADC samples) When this value is 1 rather than 0 (complex vs. real data), the time domain points and the time spacing scalers both increase by a factor of two. 10. Scan time is the total scan time of the time domain trace used for the FFT. The total scan time = (time spacing) X (time domain points – 1) 11. Current average count is the current number of data measurements that have already been combined, in the averaging calculation.
2, Service mode only	Returns the trace data of the log-magnitude versus time. (That is, the RF envelope.)
3	Returns the I and Q trace data. It is represented by I and Q pairs (in volts) versus time.
4	Returns spectrum trace data. That is, the trace of log-magnitude versus frequency. (The trace is computed using a FFT.)
5, Service mode only	Returns the averaged trace data of log-magnitude versus time. (That is, the RF envelope.)
6	Not used.
7	Returns the averaged spectrum trace data. That is, the trace of the averaged log-magnitude versus frequency.
8	Not used.
9, Service mode only	Returns a trace containing the shape of the FFT window.

n	Results Returned
10, Service mode only	Returns trace data of the phase of the FFT versus frequency.
11, cdma2000, 1xEV-DO, W-CDMA, Basic modes only	Returns linear spectrum trace data values in Volts RMS.
12, cdma2000, 1xEV-DO, W-CDMA, Basic modes only	Returns averaged linear spectrum trace data values in Volts RMS.

Terminal Code Domain Measurement

This measures the power levels of the spread channels in RF channel(s). You must be in the 1xEV-DO mode to use these commands. Use INSTRument:SElect to set the mode.

This measurement is used only for mobile stations (access terminals). When measuring base stations (network access) use Code Domain Power Measurements (MEAS:CDPower) and set SENSE:RADio:DEvice to BTS.

The general functionality of CONFigure, FETCh, MEASure, and READ are described at the beginning of this section. See the SENSE:CDPower commands for more measurement related commands.

```
:CONFigure:TCDPower
:INITiate:TCDPower
:FETCh:TCDPower [n] ?
:READ:TCDPower [n] ?
:MEASure:TCDPower [n] ?
```

Front Panel

Access: **Measure, Code Domain**

After the measurement is selected, press **Restore Meas Defaults** to restore factory defaults.

Measurement Results Available

n	Results Returned
0	Returns unprocessed I/Q trace data, as a series of trace point values, in volts. The I values are listed first in each pair, using the 0 through even-indexed values. The Q values are the odd-indexed values.

n	Results Returned
n=1 (or not specified)	<p>Returns the following 19 scalar results:</p> <ol style="list-style-type: none"> 1. RMS symbol EVM is a floating point number (in percent) of the EVM over the entire measurement area. 2. Peak symbol EVM is a floating point number (in percent) of the peak EVM in the measurement area. 3. Symbol magnitude error is a floating point number (in percent) of the average magnitude error over the entire measurement area. 4. Symbol phase error is a floating point number (in degrees) of the average phase error over the entire measurement area. 5. Total power is a floating point number (in dBm) of the total RF power over the measurement interval. 6. Average power is a floating point number (in dBm) of the power in the entire slot, for the selected code, averaged over the measurement interval. 7. Total active power is a floating point number (in dB or dBm depending on the measurement type) of the sum of the active power. 8. Pilot power is a floating point number (in dB or dBm depending on the measurement type) of the average power of the Pilot code. 9. (Reserved) the value returned is always -999. 10. (Reserved) the value returned is always -999. 11. (Reserved) the value returned is always -999. 12. (Reserved) the value returned is always -999. 13. (Reserved) the value returned is always -999. 14. Number of active channels 15. I-channel average active power is a floating point number (in dB or dBm depending on the measurement type) of the average power of the active traffic channel. 16. I-channel maximum inactive power is a floating point number (in dB or dBm depending on the measurement type) of the maximum average power of all the inactive traffic channels. 17. Q-channel average active power is a floating point number (in dB or dBm depending on the measurement type) of the average power of the active traffic channel. 18. Q-channel maximum inactive power is a floating point number (in dB or dBm depending on the measurement type) of the maximum average power of the inactive traffic channels. 19. (Reserved) the value returned is always -999.

n	Results Returned
2	<p>Returns a series of floating point numbers (in dB or dBm depending on the measurement type) that represents all the code domain powers.</p> <p>Results are returned alternatively. Total is 32 I/Q pairs. If the active channel occupies more than the max spreading factor (16) the power is duplicated.</p> <p>1st number = 1st in-phase code power over the slot 2nd number = 1st quad-phase code power over the slot ... (2×N-1)th number = Nth in-phase code power over the slot (2×N)th number = Nth quad-phase code power over a slot</p> <p>N = the number of codes detected. The total number of codes varies because of the different symbol rates of each code.</p>
3	<p>Returns a series of floating point numbers (in dB or dBm depending on the measurement type) that represents all the code domain symbol rates.</p> <p>Results are returned alternatively. Total is 32 I/Q pairs. If the active channel occupies more than the max spreading factor (16) the power is duplicated.</p> <p>1st number = 1st in-phase code symbol rates over the slot 2nd number = 1st quad-phase codesymbol rates over the slot ... (2×N-1)th number = Nth in-phase code symbol rates over the slot (2×N)th number = Nth quad-phase code symbol rates over the slot</p> <p>N = the number of codes detected. The total number of codes varies because of the different symbol rates of each code.</p>
4	<p>Returns a series of floating point numbers that show either active or inactive status for each of the code powers returned in n=2 and 3. If a code is inactive, the value returned is 0.0, otherwise a value >0.0 is returned.</p> <p>I and Q results are returned alternatively. 1st number = 1st in-phase code active flag 2nd number = 1st Quad Phase code active flag ... (2×N-1)th number = Nth in-phase code active flag (2×N)th number = Nth Quad Phase code active flag</p> <p>N = the number of codes detected. The total number of codes varies because of the different symbol rates of each code. 2nd number = 1st quad-phase code symbol rate over the slot</p>
5	<p>Returns a series of floating point numbers (in percent) that represent each sample in the <i>EVM</i> trace. The first number is the symbol 0 decision point and there are X points per symbol. Therefore, the decision points are at 0, 1×X, 2×X, 3×X. . .</p> <p>(where X = the number of points per chip)</p>

n	Results Returned
6	<p>Returns a series of floating point numbers (in percent) that represent each sample in the <i>magnitude error</i> trace. The first number is the symbol 0 decision point and there are X points per symbol. Therefore, the decision points are at 0, 1×X, 2×X, 3×X. . .</p> <p>(where X = the number of points per chip)</p>
7	<p>Returns a series of floating point numbers (in degrees) that represent each sample in the <i>phase error</i> trace. The first number is the symbol 0 decision point and there are X points per symbol. Therefore, the decision points are at 0, 1×X, 2×X, 3×X. . .</p> <p>(where X = the number of points per chip)</p>
8	<p>Returns series of floating point numbers that alternately represent I and Q pairs of the <i>corrected measured</i> trace. The magnitude of each I and Q pair is normalized to 1.0. The first number is the in-phase (I) sample of symbol 0 decision point and the second is the quadrature-phase (Q) sample of symbol 0 decision point. As in the EVM, there are X points per symbol, so that:</p> <p>1st number is I of the symbol 0 decision point 2nd number is Q of the symbol 0 decision point . . . (2×X)+1 number is I of the symbol 1 decision point (2×X)+2 number is Q of the symbol 1 decision point . . . (2×X)×N+1th number is I of the symbol N decision point (2×X)×N+2th number is Q of the symbol N decision point</p> <p>where X = the number of points per symbol, and N = the number of symbols</p>
9	<p>Returns series of floating point numbers (in dBm) that represent the trace data of the symbol power vs. time.</p>
10	<p>Returns series of floating point numbers (in dBm) that represent the trace data of the chip power vs. time.</p>
11	<p>Returns a series of floating point numbers (0.0 or 1.0) of the symbol values (demodulated bits) for the selected spread code. The results are returned as alternating values of I,Q,I,Q . . . for the entire measurement interval.</p>
12 W-CDMA mode	<p>Returns series of floating point numbers (0.0 or 1.0) of symbol values for the selected code with the period selected by Meas Interval, and Meas Offset and tDPCH, when :CALCulate:CDPower:DBITs[:FORMat] is set to BINary. Returns series of floating point numbers (0.0, 1.0 or -1.0) of symbol values for the selected code with the period selected by Meas Interval, and Meas Offset and tDPCH, when :CALCulate:CDPower:DBITs[:FORMat] is set to TRISate. “-1.0” represents DTX (Discontinuous Transmission) bit.</p>

Terminal Modulation Accuracy (Rho) Measurement

This measures the modulation accuracy of the 1xEV-DO terminal transmitter (mobile unit) by checking the magnitude and phase error and the EVM (error vector magnitude). You must be in the 1xEV-DO mode to use these commands. Use INSTRument:SELEct to set the mode.

For network access equipment, use MEAS:RHO to measure modulation accuracy, after selecting base transmitter stations using SENSE:RADio:DEVice BTS.

The general functionality of CONFigure, FETCh, MEASure, and READ are described at the beginning of this section. See the SENSE:RHO commands for more measurement related commands.

```
:CONFigure:TRHO
:INITiate:TRHO
:FETCh:TRHO [n] ?
:READ:TRHO [n] ?
:MEASure:TRHO [n] ?
```

Front Panel

Access: **Measure, Mod Accuracy**

After the measurement is selected, press **Restore Meas Defaults** to restore factory defaults.

Measurement Results Available

n	Results Returned
0	Returns unprocessed I/Q trace data, as a series of trace point values. The I values are listed first in each pair, using the 0 through even-indexed values. The Q values are the odd-indexed values.

n	Results Returned
n=1 (or not specified)	<p>Returns following 16 comma-separated scalar results, in the following order:</p> <ol style="list-style-type: none"> 1. RMS EVM – a floating point number (in percent) of EVM over the entire measurement area. 2. Peak EVM error – a floating point number (in percent) of peak EVM in the measurement area. 3. Magnitude error – a floating point number (in percent) of average magnitude error over the entire measurement area. 4. Phase error – a floating point number (in degree) of average phase error over the entire measurement area. 5. I/Q Origin Offset – a floating point number (in dB) of the I and Q error (magnitude squared) offset from the origin. 6. Frequency error – a floating point number (in Hz) of the frequency error in the measured signal. 7. Rho – a floating point number of Rho. 8. Peak code domain error – a floating point number (in percent) of peak code domain error in the measurement area. 9. Peak code domain error channel number– returns the channel number which contained the peak code domain error in the measurement area. 10. Number of active channels. <p>Following result is available for all measurement modes:</p> <ol style="list-style-type: none"> 11. Pilot Offset – a floating point number (in micro seconds) of pilot offset from the trigger point. 12. Max Inactive Channel Code Domain Power – a floating point number (in dB) of the Max Inactive Channel Code Domain Power 13. RRI Relative Power – a floating point number (in dB) of the RRI power relative to Pilot 14. DRC Channel Relative Power – a floating point number (in dB) of the DRC Channel Power relative to Pilot 15. ACK Channel Relative Power – a floating point number (in dB) of the ACK Channel Power relative to Pilot 16. Data Channel Relative Power – a floating point number (in dB) of the Data Channel Power relative to Pilot
2	<p>EVM trace – returns series of floating point numbers (in percent) that represent each sample in the EVM trace. The first number is the symbol 0 decision point. There are X points per symbol ($X = \text{points/chip}$). Therefore, the decision points are at $0, 1 \times X, 2 \times X, 3 \times X \dots$</p>

n	Results Returned
3	<p>Magnitude error trace – returns series of floating point numbers (in percent) that represent each sample in the magnitude error trace. The first number is the symbol 0 decision point. There are X points per symbol ($X = \text{points/chip}$). Therefore, the decision points are at $0, 1 \times X, 2 \times X, 3 \times X$</p> <p>. . .</p>
4	<p>Phase error trace – returns series of floating point numbers (in degrees) that represent each sample in the phase error trace. There are X points per symbol ($X = \text{points/ chip}$). Therefore, the decision points are at $0, 1 \times X, 2 \times X, 3 \times X$. . .</p>
5	<p>Corrected measured trace – returns series of floating point numbers that alternately represent I and Q pairs of the corrected measured trace. The magnitude of each I and Q pair are normalized to 1.0. The first number is the in-phase (I) sample of symbol 0 decision point and the second is the quadrature-phase (Q) sample of symbol 0 decision point. There are X points per symbol ($X = \text{points/chip}$), so the series of numbers is:</p> <p>1st number = I of the symbol 0 decision point 2nd number = Q of the symbol 0 decision point</p> <p>. . .</p> <p>$(2 \times X) + 1$, number = I of the symbol 1 decision point $(2 \times X) + 2$, number = Q of the symbol 1 decision point</p> <p>. . .</p> <p>$(2 \times X) \times N\text{th} + 1$ number = I of the symbol N decision point $(2 \times X) \times N\text{th} + 2$ number = Q of the symbol N decision point</p>
6	<p>Returns 11 comma-separated scalar values of the pass/fail (0.0=passed, or 1.0=failed) results determined by testing the EVM, Peak EVM:</p> <ol style="list-style-type: none"> 1. Test result of EVM 2. Test result of Peak EVM 3. Test result of Rho 4. Test result of Peak Code Domain Error 5. Test result of Frequency Error 6. Test result of Pilot Offset 7. Test result of Max Inactive channel code domain power 8. Test result of RRI Relative Power 9. Test result of ACK Channel Relative Power 10. Test result of DRC Channel Relative Power 11. Test result of Data Channel Relative Power

Waveform (Time Domain) Measurement

For E4406A this measures the amplitude of your input signal with respect to the frequency. It provides spectrum analysis capability using FFT (fast Fourier transform) measurement techniques. You must select the appropriate mode using INSTRUMENT:SElect, to use these commands.

For PSA this measures the amplitude of your input signal with respect to the frequency. It provides spectrum analysis capability using FFT (fast Fourier transform) measurement techniques. You must be in the Basic, cdmaOne, cdma2000, 1xEV-DO, W-CDMA, GSM (w/EDGE), NADC, or PDC mode to use these commands. Use INSTRUMENT:SElect, to select the mode.

The general functionality of CONFigure, FETCh, MEASure, and READ are described at the beginning of this section. See the SENSE:WAVEform commands for more measurement related commands.

```
:CONFigure:WAVEform
:INITiate:WAVEform
:FETCh:WAVEform[n]?
:READ:WAVEform[n]?
:MEASure:WAVEform[n]?
```

Front Panel

Access: **Measure, Waveform (Time Domain)**

After the measurement is selected, press **Restore Meas Defaults** to restore factory defaults.

Measurement Results Available

n	Results Returned
0 (see also 5)	Returns unprocessed I/Q trace data, as a series of trace point values, in volts. The I values are listed first in each pair, using the 0 through even-indexed values. The Q values are the odd-indexed values.

n	Results Returned
n=1 (or not specified)	<p>Returns the following scalar results:</p> <ol style="list-style-type: none"> 1. Sample time is a floating point number representing the time between samples when using the trace queries (n=0,2,etc). 2. Mean power is the mean power (in dBm). This is either the power across the entire trace, or the power between markers if the markers are enabled. If averaging is on, the power is for the latest acquisition. 3. Mean power averaged is the power (in dBm) for N averages, if averaging is on. This is either the power across the entire trace, or the power between markers if the markers are enabled. If averaging is on, the power is for the latest acquisition. If averaging is off, the value of the mean power averaged is the same as the value of the mean power. 4. Number of samples is the number of data points in the captured signal. This number is useful when performing a query on the signal (i.e. when n=0,2,etc.). 5. Peak-to-mean ratio has units of dB. This is the ratio of the maximum signal level to the mean power. Valid values are only obtained with averaging turned off. If averaging is on, the peak-to-mean ratio is calculated using the highest peak value, rather than the displayed average peak value. 6. Maximum value is the maximum of the most recently acquired data (in dBm). 7. Minimum value is the minimum of the most recently acquired data (in dBm).
2	<p>Returns trace point values of the entire captured signal envelope trace data. These data points are floating point numbers representing the power of the signal (in dBm). There are N data points, where N is the number of samples. The period between the samples is defined by the sample time.</p>
3, Option B7C with cdma2000, W-CDMA, Basic modes only (E4406A only)	<p>Returns magnitude values of the time data in Volts peak.</p>
4, Option B7C with cdma2000, W-CDMA, Basic modes only (E4406A only)	<p>Returns values of phase data in degrees.</p>

READ Subsystem

The READ? commands are used with several other commands and are documented in the section on the “[MEASure Group of Commands](#)” on [page 339](#).

Initiate and Read Measurement Data

:READ:<measurement> [n] ?

A READ? query must specify the desired measurement. It will cause a measurement to occur without changing any of the current settings and will return any valid results. The code number n selects the kind of results that will be returned. The available measurements and data results are described in the “[MEASure Group of Commands](#)” on [page 339](#).

SENSE Subsystem

These commands are used to set the instrument state parameters so that you can measure a particular input signal. Some SENSE commands are only for use with specific measurements found under the MEASURE key menu or the “MEASURE Group of Commands” on page 339. The measurement must be active before you can use these commands.

The SCPI default for the format of any data output is ASCII. The format can be changed to binary with FORMat:DATA which transports faster over the bus.

Code Domain Measurement

Commands for querying the code domain power measurement results and for setting to the default values are found in the “MEASURE Group of Commands” on page 339. The equivalent front panel keys for the parameters described in the following commands, are found under the **Meas Setup** key, after the **Code Domain** measurement has been selected from the **MEASURE** key menu.

Code Domain Measurement — Active Data Channel

```
[ :SENSE ] :CDPower:ACode AUTO|PREDEFINED
```

```
[ :SENSE ] :CDPower:ACode?
```

Select the Active Channel ID detection mode Auto or Predefined.

AUTO - detects Active Channel ID for Data Channel automatically.

PREDEFINED - set predefined Active Channel (all channel codes) for Data Channel.

Factory Preset: AUTO

Remarks: You must be in the 1xEV-DO mode to use this command. Use INSTRument:SElect to set the mode.

Code Domain Measurement — ADC Range

PSA

```
[ :SENSE ] :CDPower:ADC:RANGe
```

```
AUTO|APEak|APLock|NONE|P0|P6|P12|P18
```

E4406A

```
[ :SENSE ] :CDPower:ADC:RANGe
```

```
AUTO|APEak|APLock|M6|P0|P6|P12|P18|P24
```

```
[ :SENSE ] :CDPower:ADC:RANGe?
```

Select a ranging function for the ADC gain control. This is an advanced control that normally does not need to be changed. If you are measuring a CW signal, see the following description:

- AUTO - automatic ranging

For FFT spectrums, the auto ranging should not be used. An exception to this would be if you know that your signal is “bursty”. Then you might use auto to maximize the time domain dynamic range as long as you are not very interested in the FFT data.

- APEak (Auto Peak) - automatic ranging to the peak signal level

For CW signals, the default of auto-peak ranging can be used, but a better FFT measurement of the signal can be made by selecting one of the manual ranges that is available by specifying M6, or P0 through P24.

Auto peaking can cause the ADC gain to monotonically track the ranges down during the data capture. This tracking effect should be negligible for the FFT spectrum, but selecting a manual range solves this possibility. Note that if the CW signal being measured is close to the auto-ranging threshold, the noise floor may shift as much as 6 dB every sweep.

- APLock (Auto Peak Lock) - automatic ranging locked to the peak signal level

For CW signals, auto-peak lock ranging may be used. It will find the ADC gain most appropriate for this particular signal and will not track the ranges as auto-peak can. Note that if the CW signal being measured is close to the auto-ranging threshold, the noise floor may shift as much as 6 dB every sweep.

For “bursty” signals, auto-peak lock ranging should not be used. Since the ADC range can often be locked to the wrong one resulting in overloading the ADC, the measurement will fail.

- NONE - (PSA) turns off any auto-ranging without making any changes to the current setting.
- M6 - (E4406A) manually selects an ADC range that subtracts 6 dB from the fixed gain across the range. Manual ranging is best for CW signals. This is the default selection for this measurement.
- P0 thru P24 - (E4406A) manually selects one of the ADC ranges that add 0 dB to 24 dB to the fixed gain across the range. Manual ranging is best for CW signals.
- P0 thru P18 - (PSA) manually selects one of the ADC ranges that add 0 dB to 24 dB to the fixed gain across the range. Manual ranging is best for CW signals.

Factory Preset: M6

Remarks: You must be in the 1xEV-DO mode to use this command. Use INSTRument:SElect to set the mode.

History: PSA:
Added in version A.02.00
E4406A:
Added in version A.05.00

Code Domain—Data Capture Time

[:SENSe] :CDPower:CAPTure:TIME <numeric>

[:SENSe] :CDPower:CAPTure:TIME?

Set the data capture length in Power Control Groups (PCG; 1 PCG equals 1.25 ms) for cdma2000 and 1xEV-DO, or frames (1 frame equals 10 ms) for W-CDMA that will be used in the acquisition.

For cdma2000 Set the data capture length in Power Control Groups (PCG; 1 PCG equals 1.25 ms) that will be used in the acquisition.

For 1xEV-DO Set the data capture length in units of slots (1 slot equals 1.667 ms) that will be used in the acquisition.

For W-CDMA Set the data capture length in frames (1 frame equals 10 ms) for that will be used in the acquisition.

Factory Preset: 5 for cdma2000, 1xEV-DO
2.0 for W-CDMA

Range: 2 to 32 PCGs (2.5 to 40 ms) for cdma2000; 2 to 32 slots for 1xEV-DO
0.067 (any value below 1 is set to 0.067), 1.0, 2.0, 3.0, 4.0, and 8.0 frames (0.67 to 80 ms; 1/15 frame equals 1 slot) for W-CDMA. Other numeric values between 1 and 8 are rounded to the nearest integer; entries between integers are rounded up, excepting for entries above 8 which are rounded down to 8.

Remarks: You must be in the cdma2000, W-CDMA, or 1xEV-DO mode to use this command. Use INSTRument:SElect to set the mode.

Code Domain—Chip Rate

[:SENSe] :CDPower:CRATe <freq>

[:SENSe] :CDPower:CRATe?

Enter a frequency value to set the chip rate.

Factory Preset: 1.2288 MHz for cdma2000, 1xEV-DO
3.84 MHz for W-CDMA

Range: 1.10592 to 1.35168 MHz for cdma2000, 1xEV-DO
3.456 to 4.224 MHz for W-CDMA

Remarks: You must be in the cdma2000, W-CDMA, or 1xEV-DO mode to use this command. Use INSTRument:SElect to set the mode.

Code Domain—Phase Compensation by Pilot

```
[ :SENSe ] :CDPower:PILot:COMPensation [:STATE] OFF | ON | 0 | 1
```

```
[ :SENSe ] :CDPower:PILot:COMPensation [:STATE] ?
```

Turn on or off the phase compensation (1 slot-based compensation)

Factory Preset: Off

On - Perform 1 slot-based phase compensation

Off - Do not perform 1 slot-based phase compensation

Remarks: You must be in the 1xEV-DO mode to use this command. Use INSTRument:SElect to set the mode.

Code Domain—PN Offset

```
[ :SENSe ] :CDPower:PNOffset <integer>
```

```
[ :SENSe ] :CDPower:PNOffset?
```

Set a PN sequence number for the base station being tested. This value behaves as a multiplier for the Walsh codes of which length is in the unit of 64 chips.

Factory Preset: 0

Range: 0 to 511

Unit: 64 chips

Remarks: You must be in the 1xEV-DO mode to use this command. Use INSTRument:SElect to set the mode.

History: PSA:
Added in version A.02.00

E4406A:
Added in version A.05.00

Code Domain—Preamble Length

`[:SENSE] :CDPower:PREamble:LENGth <integer>`

`[:SENSE] :CDPower:PREamble:LENGth?`

Set the Preamble length manually in chips.

Factory Preset: 0

Range: 0, 64, 128, 256, 512 and 1024

Remarks: You must be in the 1xEV-DO mode to use this command. Use INSTRUMENT:SElect to set the mode.

Code Domain—Preamble Auto Detection

`[:SENSE] :CDPower:PREamble:LENGth:AUTO OFF | ON | 0 | 1`

`[:SENSE] :CDPower:PREamble:LENGth:AUTO?`

Turn the Preamble Length detection mode on or off.

On - detects the Preamble length automatically.

Off - sets the Preamble length manually by
`[:SENSE] :CDPower:PREamble:LENGth`.

Factory Preset: ON

Remarks: You must be in the 1xEV-DO mode to use this command. Use INSTRUMENT:SElect to set the mode.

Code Domain—Spectrum Normal/Invert

`[:SENSE] :CDPower:SPECTrum INVert | NORMal`

`[:SENSE] :CDPower:SPECTrum?`

Set a spectrum either to normal or inverted for the demodulation related measurements. If set to INVert, the upper and lower spectrums are swapped.

Factory Preset: NORMal

Remarks You must be in the cdmaOne, cdma2000, W-CDMA, or 1xEV-DO mode to use this command. Use INSTRUMENT:SElect to set the mode.

Code Domain—Trigger Source

```
[ :SENSe ] :CDPower:TRIGger:SOURce  
EXTernal [1] | External2 | FRAME | IF | IMMEDIATE | RFBurst
```

```
[ :SENSe ] :CDPower:TRIGger:SOURce?
```

Select one of the trigger sources used to control the data acquisitions.

EXTernal 1 – front panel external trigger input

EXTernal 2 – rear panel external trigger input

FRAMe – internal frame trigger

IF – internal IF envelope (video) trigger

IMMEDIATE – the next data acquisition is immediately taken, capturing the signal asynchronously (also called free run).

RFBurst – internal wideband RF burst envelope trigger that has automatic level control for periodic burst signals.

Factory Preset: IMMEDIATE

Remarks: You must be in the cdma2000, W-CDMA, or 1xEV-DO mode to use this command. Use INSTRUMENT:SELECT to set the mode.

Front Panel

Access: **Meas Setup, Trig Source**

Channel Power Measurement

Commands for querying the channel power measurement results and for setting to the default values are found in the “MEASure Group of Commands” on page 339. The equivalent front panel keys for the parameters described in the following commands, are found under the **Meas Setup** key, after the **Channel Power** measurement has been selected from the **MEASURE** key menu.

Channel Power—Averaging State

```
[ :SENSe ] :CHPower:AVERAge [ :STATe ] OFF | ON | 0 | 1
```

```
[ :SENSe ] :CHPower:AVERAge [ :STATe ] ?
```

Turn averaging on or off.

Factory Preset: ON

Remarks: For PSA you must be in the cdmaOne, cdma2000, W-CDMA, or 1xEV-DO mode to use this command. Use INSTRument:SELEct to set the mode.

For E4406A you must be in the Basic, cdmaOne, cdma2000, W-CDMA, or 1xEV-DO mode to use this command. Use INSTRument:SELEct to set the mode.

Channel Power—Averaging Termination Control

```
[ :SENSe ] :CHPower:AVERAge:TCONtrol EXPonential | REPEAT
```

```
[ :SENSe ] :CHPower:AVERAge:TCONtrol ?
```

Select the type of termination control used for the averaging function. This determines the averaging action after the specified number of data acquisitions (average count) is reached.

EXPonential - Each successive data acquisition after the average count is reached, is exponentially weighted and combined with the existing average.

REPEAT - After reaching the average count, the averaging is reset and a new average is started.

Factory Preset: REPEAT

Remarks: For PSA you must be in the cdmaOne, cdma2000, W-CDMA, or 1xEV-DO mode to use this command. Use INSTRument:SELEct to set the mode.

For E4406A you must be in the Basic, cdmaOne, cdma2000, W-CDMA, or 1xEV-DO mode to use this command. Use INSTRument:SELEct to set the mode.

Channel Power—Span

`[:SENSe] :CHPower:FREQuency:SPAN <freq>`

`[:SENSe] :CHPower:FREQuency:SPAN?`

Set the frequency span that will be used.

Factory Preset: 2.0 MHz for Basic, cdmaOne, cdma2000, 1xEV-DO
6.0 MHz for W-CDMA

Range: Dependent on the current setting of the channel power integration bandwidth

Default Unit: Hz

Remarks: For PSA you must be in the cdmaOne, cdma2000, W-CDMA, or 1xEV-DO mode to use this command. Use INSTRument:SElect to set the mode.

For E4406A you must be in the Basic, cdmaOne, cdma2000, W-CDMA, or 1xEV-DO mode to use this command. Use INSTRument:SElect to set the mode.

Channel Power—Data Points

`[:SENSe] :CHPower:POINTs <integer>`

`[:SENSe] :CHPower:POINTs?`

Set the number of data points that will be used. Changing this will change the time record length and resolution BW that are used.

Factory Preset: 512

Range: 64 to 32768, in a 2ⁿ sequence

Remarks: For PSA you must be in the cdmaOne, cdma2000, W-CDMA, or 1xEV-DO mode to use this command. Use INSTRument:SElect to set the mode.

For E4406A you must be in the Basic, cdmaOne, cdma2000, W-CDMA, or 1xEV-DO mode to use this command. Use INSTRument:SElect to set the mode.

Channel Power—Data Points Auto

`[:SENSe] :CHPower:POINTs:AUTO OFF | ON | 0 | 1`

`[:SENSe] :CHPower:POINTs:AUTO?`

Select auto or manual control of the data points. This is an advanced control that normally does not need to be changed. Setting this to a value other than the factory default, may cause invalid measurement

results.

OFF - the Data Points is uncoupled from the Integration BW.

ON - couples the Data Points to the Integration BW.

Factory Preset: ON

Remarks: You must be in the Basic (E4406A), cdmaOne, cdma2000, W-CDMA, 1xEV-DO mode to use this command. Use INSTRument:SElect to set the mode.

Channel Power—Sweep Time

`[:SENSe] :CHPower :SWEep :TIME <time>`

`[:SENSe] :CHPower :SWEep :TIME?`

Sets the sweep time when using the sweep mode.

Factory Preset: 68.27 μ s

17.07 μ s for W-CDMA

Range: 1 μ s to 50 ms

Default Unit: seconds

Remarks: You must be in the Basic (E4406A), cdmaOne, cdma2000, W-CDMA, or 1xEV-DO mode to use this command. Use INSTRument:SElect to set the mode.

History: E4406A:
Version A.03.00 and later

Channel Power—Sweep Time

`[:SENSe] :CHPower :SWEep :TIME :AUTO OFF | ON | 0 | 1`

`[:SENSe] :CHPower :SWEep :TIME :AUTO?`

Selects the automatic sweep time, optimizing the measurement.

Factory Preset: ON

Remarks: You must be in the Basic (E4406A), cdmaOne, cdma2000, W-CDMA, or 1xEV-DO mode to use this command. Use INSTRument:SElect to set the mode.

History: E4406A:
Version A.03.00 and later

Channel Power—Trigger Source

```
[ :SENSe ] :CHPower :TRIGger :SOURce  
EXTernal [1] | EXTernal2 | IMMEDIATE
```

```
[ :SENSe ] :CHPower :TRIGger :SOURce?
```

Select the trigger source used to control the data acquisitions. This is an Advanced control that normally does not need to be changed.

EXTernal 1 - front panel external trigger input

EXTernal 2 - rear panel external trigger input

IMMEDIATE - the next data acquisition is immediately taken (also called Free Run).

Factory Preset: IMMEDIATE

Remarks: For PSA you must be in the cdmaOne, cdma2000, W-CDMA, or 1xEV-DO mode to use this command. Use INSTRUMENT:SElect to set the mode.

For E4406A you must be in the Basic, cdmaOne, cdma2000, W-CDMA, or 1xEV-DO mode to use this command. Use INSTRUMENT:SElect to set the mode.

Signal Corrections Commands

Correction for BTS RF Port External Attenuation

`[:SENSE] :CORRection:BTS [:RF] :LOSS <rel_power>`

`[:SENSE] :CORRection:BTS [:RF] :LOSS?`

Set equal to the external attenuation used when measuring base transmission stations.

Factory Preset: 0.0 dB

Range: -50 to 100.0 dB for GSM, EDGE
 -100.0 to 100.0 dB for cdma2000, W-CDMA, 1xEV-DO

Default Unit: dB

Remarks: Global to the current mode.

You must be in the GSM, EDGE, cdma2000, W-CDMA, or 1xEV-DO mode to use this command. Use INSTRUMENT:SElect to set the mode.

Correction for MS RF Port External Attenuation

`[:SENSE] :CORRection:MS [:RF] :LOSS <rel_power>`

`[:SENSE] :CORRection:MS [:RF] :LOSS?`

Set the correction equal to the external attenuation used when measuring mobile stations.

Factory Preset: 0.0 dB

Range: -50 to 100.0 dB for cdmaOne, GSM, EDGE, iDEN
 -100.0 to 100.0 dB for cdma2000, W-CDMA, 1xEV-DO
 -50.0 to 50.0 dB for NADC, PDC

Default Unit: dB

Remarks: For E4406A you must be in the cdmaOne, GSM, EDGE (w/GSM), cdma2000, W-CDMA, iDEN, NADC, PDC, or 1xEV-DO mode to use this command. Use INSTRUMENT:SElect to set the mode.

For PSA you must be in the cdmaOne, GSM (w/EDGE), cdma2000, W-CDMA, NADC, PDC, or 1xEV-DO mode to use this command. Use INSTRUMENT:SElect to set the mode.

Value is global to the current mode.

QPSK Error Vector Magnitude Measurement

Commands for querying the QPSK error vector magnitude measurement results and for setting to the default values are found in the “MEASure Group of Commands” on page 339. The equivalent front panel keys for the parameters described in the following commands, are found under the **Meas Setup** key, after the **QPSK EVM** measurement has been selected from the **MEASURE** key menu.

QPSK Error Vector Magnitude — ADC Range

PSA

```
[ :SENSe ] :EVMQpsk:ADC:RANGe  
AUTO | APEak | APLOCK | NONE | P0 | P6 | P12 | P18
```

E4406A

```
[ :SENSe ] :EVMQpsk:ADC:RANGe  
AUTO | APEak | APLOCK | M6 | P0 | P6 | P12 | P18 | P24
```

```
[ :SENSe ] :EVMQpsk:ADC:RANGe?
```

Select a ranging function for the ADC gain control. This is an advanced control that normally does not need to be changed. If you are measuring a CW signal, see the following description:

- AUTO - automatic ranging

For FFT spectrums, the auto ranging should not be used. An exception to this would be if you know that your signal is “bursty”. Then you might use auto to maximize the time domain dynamic range as long as you are not very interested in the FFT data.

- APEak (Auto Peak) - automatic ranging to the peak signal level

For CW signals, the default of auto-peak ranging can be used, but a better FFT measurement of the signal can be made by selecting one of the manual ranges that is available by specifying M6, or P0 through P24.

Auto peaking can cause the ADC gain to monotonically track the ranges down during the data capture. This tracking effect should be negligible for the FFT spectrum, but selecting a manual range solves this possibility. Note that if the CW signal being measured is close to the auto-ranging threshold, the noise floor may shift as much as 6 dB every sweep.

- APLOCK (Auto Peak Lock) - automatic ranging locked to the peak signal level

For CW signals, auto-peak lock ranging may be used. It will find the ADC gain most appropriate for this particular signal and will not track the ranges as auto-peak can. Note that if the CW signal being measured is close to the auto-ranging threshold, the noise floor may shift as much as 6 dB every sweep.

For “bursty” signals, auto-peak lock ranging should not be used. Since the ADC range can often be locked to the wrong one resulting in overloading the ADC, the measurement will fail.

- NONE - (PSA) turns off any auto-ranging without making any changes to the current setting.
- M6 - (E4406A) manually selects an ADC range that subtracts 6 dB from the fixed gain across the range. Manual ranging is best for CW signals.
- P0 thru P18 - (PSA) manually selects one of the ADC ranges that add 0 dB to 24 dB to the fixed gain across the range. Manual ranging is best for CW signals.
- P0 thru P24 - (E4406A) manually selects one of the ADC ranges that add 0 dB to 24 dB to the fixed gain across the range. Manual ranging is best for CW signals.

Factory Preset: M6

Remarks: You must be in the 1xEV-DO mode to use this command. Use INSTRUMENT:SElect to set the mode.

History: PSA:
Added in version A.02.00

E4406A:
Added in version A.05.00

QPSK Error Vector Magnitude—Average Count

[:SENSE] :EVMQpsk:AVERAge:COUNT <integer>

[:SENSE] :EVMQpsk:AVERAge:COUNT?

Set the number of data acquisitions that will be averaged. After the specified number of average counts, the average mode (termination control) setting determines the average action.

Factory Preset: 10

Range: 1 to 10,000

Remarks: You must be in the cdma2000, W-CDMA, or 1xEV-DO mode to use this command. Use INSTRUMENT:SElect to set the mode.

QPSK Error Vector Magnitude—Averaging State

[:SENSE] :EVMQpsk:AVERAge [:STATe] OFF | ON | 0 | 1

[:SENSE] :EVMQpsk:AVERAge [:STATe] ?

Turn the averaging function on or off.

Factory Preset: ON

Remarks: You must be in the cdma2000, W-CDMA, or 1xEV-DO mode to use this command. Use INSTRUMENT:SELECT to set the mode.

QPSK Error Vector Magnitude—Averaging Termination Control

```
[ :SENSe ] :EVMQpsk :AVERage :TCONtrol EXPonential | REPeat
```

```
[ :SENSe ] :EVMQpsk :AVERage :TCONtrol?
```

Select the type of termination control used to averaging. This determines the averaging action after the specified number of data acquisitions (average count) is reached.

EXPonential – Each successive data acquisition after the average count is reached, is exponentially weighted and combined with the existing average.

REPeat – After reaching the average count, the averaging is reset and a new average is started.

Factory Preset: REPeat

Remarks: You must be in the cdma2000, W-CDMA, or 1xEV-DO mode to use this command. Use INSTRUMENT:SELECT to set the mode.

QPSK Error Vector Magnitude—Chip Rate

```
[ :SENSe ] :EVMQpsk :CRATe <freq>
```

```
[ :SENSe ] :EVMQpsk :CRATe?
```

Enter a frequency value to set the chip rate.

Factory Preset: 1.2288 MHz for cdma2000, 1xEV-DO

3.84 MHz for W-CDMA

Range: 1.10592 to 1.35168 MHz for cdma2000, 1xEV-DO

3.456 to 4.224 MHz for W-CDMA

Default Unit: Hz

Remarks: You must be in the cdma2000, W-CDMA, or 1xEV-DO mode to use this command. Use INSTRUMENT:SELECT to set the mode.

QPSK Error Vector Magnitude—RF Carrier Mode

`[:SENSE] :EVMQpsk:RFCarrier MULTiple | SINGle`

`[:SENSE] :EVMQpsk:RFCarrier?`

Select either the single carrier mode or the multiple carrier mode.

MULTiple – The measurement assumes that the input signal is the multiple carriers with adjacent channel signals. The filter is used to cut the adjacent channel signals. (The filter may affect the measurement result.)

SINGle – The measurement assumes that the input signal is the single carrier without adjacent channel signals. No filter is used for better measurement.

Factory Preset: SINGle

Remarks: You must be in the cdma2000 or 1xEV-DO mode to use this command. Use INSTRUMENT:SELEct to set the mode.

QPSK Error Vector Magnitude—Measurement Interval

`[:SENSE] :EVMQpsk:SWEep:POINTs <integer>`

`[:SENSE] :EVMQpsk:SWEep:POINTs?`

Set the number of data points that will be used as the measurement interval.

Factory Preset: 256 chips

96 chips for 1xEV-DO

2560 chips (1 slot) for W-CDMA

Range: 128 to 1536 chips for cdma2000

128 to 2560 chips for W-CDMA

32 to 2048 chips for 1xEV-DO

Remarks: You must be in the cdma2000, W-CDMA, or 1xEV-DO mode to use this command. Use INSTRUMENT:SELEct to set the mode.

QPSK Error Vector Magnitude—Measurement Offset

`[:SENSE] :EVMQpsk:SWEep:POINTs:OFFSet <number>`

`[:SENSE] :EVMQpsk:SWEep:POINTs:OFFSet?`

Set the number of data points that will be offset.

Factory Preset: 464.0 chips

Range: 22.0 to 2048.0 chips

Remarks: You must be in the 1xEV-DO mode to use this command. Use INSTRument:SELEct to set the mode.

History: PSA:
Added in version A.02.00
E4406A:
Added in version A.05.00

QPSK Error Vector Magnitude—Trigger Source

```
[ :SENSe ] :EVMQpsk :TRIGger :SOURce  
EXTernal [1] | EXTernal2 | FRAMe | IF | IMMEDIATE | RFBurst
```

```
[ :SENSe ] :EVMQpsk :TRIGger :SOURce?
```

Select one of the trigger sources used to control the data acquisitions.

EXTernal 1 – front panel external trigger input

EXTernal 2 – rear panel external trigger input

FRAMe – internal frame trigger

IF – internal IF envelope (video) trigger

IMMEDIATE – the next data acquisition is immediately taken, capturing the signal asynchronously (also called free run)

RFBurst – wideband RF burst envelope trigger that has automatic level control for periodic burst signals

Factory Preset: IMMEDIATE

Remarks: You must be in the cdma2000, W-CDMA, or 1xEV-DO mode to use this command. Use INSTRument:SELEct to set the mode.

RF Input Signal Alignments

Select the Input Signal

(PSA)

```
[ :SENSe ] :FEED RF | AREFERENCE | IFALIGN
```

(E4406A)

```
[ :SENSe ] :FEED RF | IQ | IONLY | QONLY | AREFERENCE | IFALIGN
```

```
[ :SENSe ] :FEED?
```

Selects the input signal. The default input signal is taken from the front panel RF input port. For calibration and testing purposes the input signal can be taken from an internal 321.4 MHz IF alignment signal or an internal 50 MHz amplitude reference source.

For E4406A if the baseband IQ option (Option B7C) is installed, I and Q input ports are added to the front panel. The I and Q ports accept the in-phase and quadrature components of the IQ signal, respectively. The input signal can be taken from either or both ports.

RF selects the signal from the front panel RF INPUT port.

IQ selects the combined signals from the front panel optional I and Q input ports. (E4406A with Option B7C in Basic, W-CDMA, cdma2000, EDGE(w/GSM) modes)

IONLY selects the signal from the front panel optional I input port. (E4406A with Option B7C in Basic mode)

QONLY selects the signal from the front panel optional Q input port. (E4406A with Option B7C in Basic mode)

AREFERENCE selects the internal 50 MHz amplitude reference signal.

IFALIGN selects the internal, 321.4 MHz, IF alignment signal.

Factory Preset: RF

Front Panel

Access: **Input, Input Port**

History: E4406A:
modified in version A.05.00

Intermodulation Measurement

Commands for querying the intermodulation measurement results and for setting to the default values are found in the “MEASure Group of Commands” on page 339. The equivalent front panel keys for the parameters described in the following commands, are found under the **Meas Setup** key, after the **Intermod** measurement has been selected from the **MEASURE** key menu.

History: E4406A:
Added version A.04.00 and later

Intermodulation—Average Count

```
[ :SENSe ] :IM:AVERAge:COUNT <number>
```

```
[ :SENSe ] :IM:AVERAge:COUNT?
```

Set the number of data acquisitions that will be averaged. After the specified number of average counts, the average mode (termination control) setting determines the average action.

Factory Preset: 10

Range: 1 to 10,000

Remarks: You must be in the cdma2000, W-CDMA, or 1xEV-DO mode to use this command. Use INSTRument:SElect to set the mode.

Intermodulation—Averaging State

```
[ :SENSe ] :IM:AVERAge [ :STATe ] OFF | ON | 0 | 1
```

```
[ :SENSe ] :IM:AVERAge [ :STATe ] ?
```

Turn the averaging function on or off.

Factory Preset: ON

Remarks: You must be in the cdma2000, W-CDMA, or 1xEV-DO mode to use this command. Use INSTRument:SElect to set the mode.

Intermodulation—Averaging Termination Control

```
[ :SENSe ] :IM:AVERAge:TCONTrOl EXPOnentiaL | REPeat
```

```
[ :SENSe ] :IM:AVERAge:TCONTrOl?
```

Select the type of termination control used for averaging. This determines the averaging action after the specified number of data acquisitions (average count) is reached.

EXPOnential – Each successive data acquisition after the average count is reached, is exponentially weighted and combined with the existing average.

REPeat – After reaching the average count, the averaging is reset and a new average is started.

Factory Preset: REPeat

Remarks: You must be in the cdma2000, W-CDMA, or 1xEV-DO mode to use this command. Use INSTRument:SElect to set the mode.

Intermodulation—Integration Bandwidth

`[:SENSE] :IM:BANDwidth | BWIDth :INTEgration <freq>`

`[:SENSE] :IM:BANDwidth | BWIDth :INTEgration ?`

Set the Integration Bandwidth (IBW) that will be used.

Factory Preset: 1.23 MHz for cdma2000, 1xEV-DO

3.84 MHz for W-CDMA

Range: 100.0 kHz to 5.0 MHz

Default Unit: Hz

Remarks: You must be in the cdma2000, W-CDMA, or 1xEV-DO mode to use this command. Use INSTRument:SElect to set the mode.

Intermodulation—Resolution Bandwidth

`[:SENSE] :IM:BANDwidth | BWIDth [:RESolution] <freq>`

`[:SENSE] :IM:BANDwidth | BWIDth [:RESolution] ?`

Set the resolution bandwidth that will be used for the Transmitter IM measurement mode. If span is set to a value greater than 5 MHz, minimum resolution bandwidth is limited to 1 kHz.

Factory Preset: Auto coupled.

Range: 100 Hz to 300.0 kHz

Default Unit: Hz

Remarks: You must be in the cdma2000, W-CDMA, or 1xEV-DO mode to use this command. Use INSTRument:SElect to set the mode.

Intermodulation—Resolution Bandwidth State

```
[ :SENSe ] :IM:BANDwidth | BWIDth [ :RESolution ] :AUTO OFF | ON | 0 | 1  
[ :SENSe ] :IM:BANDwidth | BWIDth [ :RESolution ] :AUTO?
```

Select auto (default value) or manual (user entered value) to set the resolution bandwidth.

Factory Preset: ON

Remarks: You must be in the cdma2000, W-CDMA, or 1xEV-DO mode to use this command. Use INSTRUMENT:SELEct to set the mode.

Intermodulation—Base Frequency Auto Search

```
[ :SENSe ] :IM:FREQuency :AUTO OFF | ON | 0 | 1  
[ :SENSe ] :IM:FREQuency :AUTO?
```

Turn the base frequency auto search function on or off.

OFF – the frequencies set by the [:SENSe] :IM:FREQuency are used.

ON – automatically determined by searching the entire span.

Factory Preset: ON

Remarks: You must be in the cdma2000, W-CDMA, or 1xEV-DO mode to use this command. Use INSTRUMENT:SELEct to set the mode.

Intermodulation—Base Frequencies Delta

```
[ :SENSe ] :IM:FREQuency [ :BASE ] :DELTA <freq>  
[ :SENSe ] :IM:FREQuency [ :BASE ] :DELTA?
```

Set the delta frequency which is (the base upper frequency – the base lower frequency).

Factory Preset: Auto coupled.

Range: E4406A
–4.3214 GHz to 4.3214 GHz

PSA
–3.0000 GHz to 3.0000 GHz

Default Unit: Hz

Remarks: Frequency step value is set by
[:SENSe] :FREQuency :CENTer :STEP [:INCRement]
You must be in the cdma2000, W-CDMA, or 1xEV-DO

mode to use this command. Use INSTRUMENT:SElect to set the mode.

Intermodulation—Base Lower Frequency

`[:SENSE] :IM:FREQUENCY [:BASE] :LOWer <freq>`

`[:SENSE] :IM:FREQUENCY [:BASE] :LOWer?`

Set the frequency value of the base lower frequency. The available lower limit value is dependent on the Resolution Bandwidth setting.

Factory Preset: Auto coupled.

Range: E4406A
1 kHz to 4.3214 GHz

PSA
1 kHz to 3.0 GHz

Default Unit: Hz

Remarks: Frequency step value is set by
`[:SENSE] :FREQUENCY:CENTer:STEP [:INCRement]`

You must be in the cdma2000, W-CDMA, or 1xEV-DO mode to use this command. Use INSTRUMENT:SElect to set the mode.

Intermodulation—Base Upper Frequency

`[:SENSE] :IM:FREQUENCY [:BASE] :UPPer <freq>`

`[:SENSE] :IM:FREQUENCY [:BASE] :UPPer?`

Set the frequency value of the base upper frequency. The available lower limit value is dependent on the Resolution Bandwidth setting.

Factory Preset: Auto coupled.

Range: E4406A
1 kHz to 4.3214 GHz

PSA
1 kHz to 3.0 GHz

Default Unit: Hz

Remarks: Frequency step value is set by
`[:SENSE] :FREQUENCY:CENTer:STEP [:INCRement]`

You must be in the cdma2000, W-CDMA, or 1xEV-DO mode to use this command. Use INSTRUMENT:SElect to set the mode.

Intermodulation—Span

`[:SENSe] :IM:FREQuency:SPAN <freq>`

`[:SENSe] :IM:FREQuency:SPAN?`

Set the span.

Factory Preset: 20.0 MHz for cdma2000, 1xEV-DO
50.0 MHz for W-CDMA

Range: 100.0 kHz to 100.0 MHz

Default Unit: Hz

Remarks: You must be in the cdma2000, W-CDMA, or 1xEV-DO mode to use this command. Use INSTRument:SELEct to set the mode.

Intermodulation—Measurement Mode

`[:SENSe] :IM:MODE AUTO | TWOTone | TXIM`

`[:SENSe] :IM:MODE?`

Select the measurement mode of the intermodulation measurement.

AUTO – Automatically identifies the intermodulation caused by the two-tone or transmit intermodulation signals.

Two-tone (TWOTone)– Measures the two-tone intermodulation products.

Transmit (TXIM)– Measures the transmit intermodulation products.

Factory Preset: AUTO

Remarks: You must be in the cdma2000, W-CDMA, or 1xEV-DO mode to use this command. Use INSTRument:SELEct to set the mode.

Intermodulation—Measurement Reference

`[:SENSe] :IM:REFErence AUTO | AVERAge | LOWer | UPPer`

`[:SENSe] :IM:REFErence?`

Select the measurement reference of the intermodulation measurement.

AUTO – Automatically sets the highest level signal in two base signals as measurement reference.

AVERage – Sets the average level of the base lower carrier and upper carrier frequency as measurement reference.

LOWer – Sets the base lower carrier as measurement reference.

UPPer – Sets the base upper carrier as measurement reference.

Factory Preset: AUTO

Remarks: You must be in the cdma2000, W-CDMA, or 1xEV-DO mode to use this command. Use INSTRument:SElect to set the mode.

Occupied Bandwidth Measurement

Commands for querying the occupied bandwidth measurement results and for setting to the default values are found in the “MEASure Group of Commands” on page 339. The equivalent front panel keys for the parameters described in the following commands, are found under the **Meas Setup** key, after the **Occupied BW** measurement has been selected from the **MEASURE** key menu.

Occupied Bandwidth—Average Count

```
[ :SENSe ] :OBW:AVERAge:COUNT <integer>
```

```
[ :SENSe ] :OBW:AVERAge:COUNT?
```

Set the number of data acquisitions that will be averaged. After the specified number of average counts, the average mode (termination control) setting determines the average action.

Factory Preset: 10

Range: 1 to 10,000

Remarks: This command is used for measurements in the MEASURE menu.

You must be in the PDC, cdma2000, W-CDMA, or 1xEV-DO mode to use this command. Use INSTRument:SElect to set the mode.

History: E4406A:
Version A.02.00 or later

Front Panel

Access: **Meas Setup, Avg Number**

Occupied Bandwidth—Averaging State

```
[ :SENSe ] :OBW:AVERAge [ :STATe ] OFF | ON | 0 | 1
```

```
[ :SENSe ] :OBW:AVERAge [ :STATe ] ?
```

Turn the averaging function on or off.

Factory Preset: ON

Remarks: You must be in the PDC, cdma2000, W-CDMA, or 1xEV-DO mode to use this command. Use INSTRument:SElect to set the mode.

History: E4406A:
Version A.02.00 or later

Front Panel

Access: **Meas Setup, Avg Number**

Occupied Bandwidth—Averaging Termination Control

```
[ :SENSe ] :OBW:AVERAge:TCONtrol EXPonential | REPEAT
```

```
[ :SENSe ] :OBW:AVERAge:TCONtrol?
```

Select the type of termination control used for the averaging function. This determines the averaging action after the specified number of data acquisitions (average count) is reached.

EXPonential - After the average count is reached, each successive data acquisition is exponentially weighted and combined with the existing average.

REPEAT - After reaching the average count, the averaging is reset and a new average is started.

Factory Preset: EXPonential for PDC

REPEAT for cdma2000, W-CDMA, 1xEV-DO

Remarks: You must be in the PDC, cdma2000, W-CDMA, or 1xEV-DO mode to use this command. Use INSTRument:SElect to set the mode.

History: E4406A:
Version A.02.00 or later

Front Panel

Access: Meas Setup, Avg Mode

Occupied Bandwidth—Resolution Bandwidth

```
[ :SENSe ] :OBW:BANDwidth | BWIDth [ :RESolution ] <freq>
```

```
[ :SENSe ] :OBW:BANDwidth | BWIDth [ :RESolution ] ?
```

Set the resolution bandwidth that will be used.

Factory Preset: 30.0 kHz

Range: 1.0 kHz to 1.0 MHz

Default Unit: Hz

Remarks: You must be in the cdma2000, W-CDMA, or 1xEV-DO mode to use this command. Use INSTRument:SElect to set the mode.

Occupied Bandwidth—FFT Window

```
[ :SENSe ] :OBW:FFT:WINDow [ :TYPE ]
```

BH4Tap | BLACkman | FLATtop | GAUSSian | HAMMing | HANNing | KB70 | KB90 |
KB110 | UNIForm

[:SENSe] :OBW:FFT:WINDow [:TYPE] ?

Select the FFT window type.

BH4Tap - Blackman Harris with 4 taps

BLACkman - Blackman

FLATtop - flat top, set to the default (for high amplitude accuracy)

GAUSSian - Gaussian with alpha of 3.5

HAMMing - Hamming

HANNing - Hanning

KB70, 90, and 110 - Kaiser Bessel with sidelobes at -70, -90, or
-110 dBc

UNIForm - no window is used. (This is the unity response.)

Factory Preset: GAUSSian

Remarks: You must be in the cdma2000, W-CDMA, or 1xEV-DO
mode to use this command. Use INSTRument:SElect to
set the mode.

Occupied Bandwidth—Span

[:SENSe] :OBW:FREQuency:SPAN <freq>

[:SENSe] :OBW:FREQuency:SPAN?

Set the occupied bandwidth span. The analyzer span will retain this
value throughout the measurement.

Factory Preset: 10.0 MHz

3.75 MHz for cdma2000, 1xEV-DO

Range: 10.0 kHz to 10.0 MHz

Default Unit: Hz

Remarks: You must be in the PDC, cdma2000, W-CDMA, or
1xEV-DO mode to use this command. Use
INSTRument:SElect to set the mode.

Occupied Bandwidth—Trigger Source

iDEN mode (E4406A)

[:SENSe] :OBW:TRIGger:SOURce

EXTernal [1] | EXTernal2 | IF | IMMEDIATE | RFBurst

[:SENSE] :OBW:TRIGger:SOURce?

PDC mode

[:SENSE] :OBW:TRIGger:SOURce

EXTernal [1] | EXTernal2 | IF | IMMEDIATE | RFBurst

[:SENSE] :OBW:TRIGger:SOURce?

cdma2000, W-CDMA, 1xEV-DO mode

[:SENSE] :OBW:TRIGger:SOURce

EXTernal [1] | EXTernal2 | FRAME | IF | IMMEDIATE | LINE | RFBurst

[:SENSE] :OBW:TRIGger:SOURce?

Select one of the trigger sources used to control the data acquisitions for the occupied bandwidth measurement.

EXTernal1 – rear panel external trigger input

EXTernal2 – front panel external trigger input

FRAME – internal frame trigger (cdma2000, W-CDMA, 1xEV-DO mode only)

IF – internal IF envelope (video) trigger

IMMEDIATE – the next data acquisition is immediately taken, capturing the signal asynchronously (also called free run)

LINE – power line (cdma2000, W-CDMA, 1xEV-DO mode only)

RFBurst – wideband RF burst envelope trigger that has automatic level control for periodic burst signals

Factory Preset: IMMEDIATE for BS in PDC, cdma2000, W-CDMA, 1xEV-DO mode

RFBurst for MS in PDC, iDEN (E4406A) mode

RFBurst for iDEN (E4406A)

Remarks:

You must be in the PDC, iDEN (E4406A), cdmaOne, cdma2000, W-CDMA, or 1xEV-DO mode to use this command. Use INSTRUMENT:SElect to set the mode.

History:

E4406A:

Version A.02.00 or later

RF Power Commands

RF Port Input Attenuation

```
[ :SENSe ] :POWer [ :RF ] :ATTenuation <rel_power>
```

```
[ :SENSe ] :POWer [ :RF ] :ATTenuation?
```

Set the RF input attenuator. This value is set at its auto value if RF input attenuation is set to auto.

Factory Preset: 0 dB

12 dB for iDEN (E4406A)

Range: 0 to 40 dB

Default Unit: dB

Front Panel

Access: **Input, Input Atten**

Internal RF Preamplifier Control

```
[ :SENSe ] :POWer [ :RF ] :GAIN [ :STATe ] OFF | ON | 0 | 1
```

```
[ :SENSe ] :POWer [ :RF ] :GAIN [ :STATe ] ?
```

Turns the internal preamp on or off for the currently selected measurement. Requires Option 1DS.

Factory Preset: OFF

Front Panel

Access: **Input/Output, More (1 of 2), Int Preamp for Optional Personalities.**

AMPLITUDE/Y Scale, More (1 of 3), Int Preamp for SA mode

Remarks: For PSA you must be in W-CDMA, cdma2000, or 1xEV-DO mode to use this command. Use INSTRUMENT:SElect to set the mode. BEFORE you can turn on the preamp using the :SENSe command, you must also send the following command- :CONFigure:RHO | EVMQpsk | CDPower.

Internal RF Preamplifier Attenuation

```
[ :SENSe ] :POWer [ :RF ] :GAIN:ATTenuation <rel_power>
```

```
[ :SENSe ] :POWer [ :RF ] :GAIN:ATTenuation?
```

Specifies the internal mechanical attenuator setting when the internal preamp is on. Requires Option 1DS. This not the same attenuator used

when the preamp is OFF.

Factory Preset: 0 [dB]

Front Panel

Access: **Input/Output, More (1 of 2), Int Preamp for Optional Personalities.**
AMPLITUDE/Y Scale, More (1 of 3), Int Preamp for SA mode

Range: 0,10, or 20 [dB]
Other numbers between 0 and 20 are rounded to the nearest number; entries between numbers are rounded up. Entries above 20 are rounded down to 20.

Remarks: You must be in W-CDMA, cdma2000, or 1xEV-DO mode with the preamp ON to use this command. Use INSTRUMENT:SElect to set the mode. BEFORE you can turn on the preamp using the :SENSe command, you must also send the following command- :CONFigure:RHO | EVMQpsk | CDPower.

Key Path: Input/Output, More (1 of 2), Attenuation

State Saved: Saved in Instrument State

RF Port Power Range Auto

[:SENSe] :POWER [:RF] :RANGe :AUTO OFF | ON | 0 | 1

[:SENSe] :POWER [:RF] :RANGe :AUTO?

Select the RF port power range to be set either automatically or manually.

ON - power range is automatically set as determined by the actual measured power level at the start of a measurement.

OFF - power range is manually set

Factory Preset: ON

Remarks: You must be in the cdmaOne, GSM, EDGE, NADC, PDC, cdma2000, W-CDMA, mode to use this command. Use INSTRUMENT:SElect to set the mode.

Front Panel

Access: **Input, Max Total Pwr (at UUT)**

RF Port Power Range Maximum Total Power

[:SENSe] :POWER [:RF] :RANGe [:UPPer] <power>

[:SENSe] :POWer [:RF] :RANGe [:UPPer] ?

Set the maximum expected total power level at the radio unit under test. This value is ignored if RF port power range is set to auto. External attenuation required above 30 dBm.

Factory Preset: -15.0 dBm

Range: -100.0 to 80.0 dBm for EDGE, GSM
 -100.0 to 27.7 dBm for cdmaOne, iDEN (E4406A)
 -200.0 to 50.0 dBm for NADC, PDC
 -200.0 to 100.0 dBm for cdma2000, W-CDMA

Default Unit: dBm

Remarks: Global to the current mode. This is coupled to the RF input attenuation

For E4406A you must be in the Service, cdmaOne, EDGE(w/GSM), GSM, iDEN, NADC, PDC, cdma2000, or W-CDMA mode to use this command. Use INSTRument:SElect to set the mode.

For PSA you must be in the cdmaOne, GSM, EDGE, NADC, PDC, cdma2000, or W-CDMA mode to use this command. Use INSTRument:SElect to set the mode.

Front Panel

Access: **Input, Max Total Pwr (at UUT)**

Power Statistics CCDF Measurement

Commands for querying the statistical power measurement of the complementary cumulative distribution function (CCDF) measurement results and for setting to the default values are found in the “[MEASure Group of Commands](#)” on page 339. The equivalent front panel keys for the parameters described in the following commands, are found under the **Meas Setup** key, after the **Power Stat CCDF** measurement has been selected from the **MEASURE** key menu.

History: E4406A:
Added PStatistic to Basic Mode version A.04.00

Power Statistics CCDF—Channel Bandwidth

```
[ :SENSe ] :PStatistic: BANDwidth | BWIDth <freq>
[ :SENSe ] :PStatistic: BANDwidth | BWIDth ?
```

Enter a frequency value to set the channel bandwidth that will be used for data acquisition.

Factory Preset: 5.0 MHz

Range: 10.0 kHz to 6.7 MHz

Default Unit: Hz

Remarks: You must be in the Basic (E4406A), cdma2000, W-CDMA, or 1xEV-DO mode to use this command. Use INSTRument:SElect to set the mode.

Power Statistics CCDF—Sample Counts

```
[ :SENSe ] :PStatistic: COUNTs <integer>
[ :SENSe ] :PStatistic: COUNTs ?
```

Enter a value to set the sample counts. Measurement stops when the sample counts reach this value.

Factory Preset: 10,000,000

Range: 1,000 to 2,000,000,000

Unit: counts

Remarks: You must be in the Basic (E4406A), cdma2000, W-CDMA, or 1xEV-DO mode to use this command. Use INSTRument:SElect to set the mode.

Power Statistics CCDF—Sweep Time

```
[ :SENSe ] :PStatistic: SWEEp: TIME <time>
```

```
[ :SENSe ] :PStatistic:SWEep:TIME?
```

Enter a value to set the measurement interval that will be used to make measurements.

Factory Preset: 1.0 ms

Range: 0.1 ms to 10 ms

Remarks: You must be in the Basic, cdma2000, W-CDMA, or 1xEV-DO mode to use this command. Use INSTRument:SElect to set the mode.

Power Statistics CCDF—Trigger Source

```
[ :SENSe ] :PStatistic:TRIGger:SOURce  
EXTERNAL [1] | EXTERNAL2 | FRAME | IF | IMMEDIATE | RFBURST
```

```
[ :SENSe ] :PStatistic:TRIGger:SOURce?
```

Select one of the trigger sources used to control the data acquisitions.

EXTERNAL 1 - front panel external trigger input

EXTERNAL 2 - rear panel external trigger input

FRAME - uses the internal frame timer, which has been synchronized to the selected burst sync.

IF - internal IF envelope (video) trigger

IMMEDIATE - the next data acquisition is immediately taken, capturing the signal asynchronously (also called Free Run).

RFBURST - wideband RF burst envelope trigger that has automatic level control for periodic burst signals.

Factory Preset: IMMEDIATE

Remarks: You must be in the Basic (E4406A), cdma2000, W-CDMA, or 1xEV-DO mode to use this command. Use INSTRument:SElect to set the mode.

Power vs. Time Measurement

Commands for querying the power versus time measurement results and for setting to the default values are found in the “MEASure Group of Commands” on page 339. The equivalent front panel keys for the parameters described in the following commands, are found under the **Meas Setup** key, after the **GMSK Pwr vs TimePower vs Time** measurement has been selected from the **MEASURE** key menu.

Power vs. Time—Number of Bursts Averaged

```
[ :SENSE ] :PVTTime:AVERage:COUNT <integer>
```

```
[ :SENSE ] :PVTTime:AVERage:COUNT?
```

Set the number of bursts that will be averaged. After the specified number of bursts (average counts), the averaging mode (terminal control) setting determines the averaging action.

Factory Preset: 15

100 for 1xEV-DO

Range: 1 to 10,000

Remarks: For E4406A you must be in the EDGE(w/GSM), GSM, 1xEV-DO, or Service mode to use this command. Use INSTRument:SElect to set the mode.

For PSA you must be in the GSM, EDGE, or 1xEV-DO mode to use this command. Use INSTRument:SElect to set the mode.

Power vs. Time—Averaging State

```
[ :SENSE ] :PVTTime:AVERage [ :STATe ] OFF | ON | 0 | 1
```

```
[ :SENSE ] :PVTTime:AVERage [ :STATe ] ?
```

Turn averaging on or off.

Factory Preset: OFF

ON for 1xEV-DO, W-CDMA

Remarks: For E4406A you must be in the EDGE(w/GSM), GSM, 1xEV-DO, W-CDMA, or Service mode to use this command. Use INSTRument:SElect to set the mode.

For PSA you must be in the GSM, EDGE, 1xEV-DO, or W-CDMA mode to use this command. Use INSTRument:SElect to set the mode.

Power vs. Time—Averaging Mode

```
[[:SENSe]:PVTime:AVERAge:TCONtrol EXPonential|REPeat  
[:SENSe]:PVTime:AVERAge:TCONtrol?
```

Select the type of termination control used for the averaging function. This specifies the averaging action after the specified number of bursts (average count) is reached.

EXPonential - Each successive data acquisition after the average count is reached is exponentially weighted and combined with the existing average.

REPeat - After reaching the average count, the averaging is reset and a new average is started.

Factory Preset: EXPonential

REPeat for 1xEV-DO, W-CDMA

Remarks: For E4406A you must be in the EDGE(w/GSM), GSM, 1xEV-DO, W-CDMA, or Service mode to use this command. Use INSTRument:SElect to set the mode.

For PSA you must be in the GSM, EDGE, 1xEV-DO or W-CDMA mode to use this command. Use INSTRument:SElect to set the mode.

Power vs. Time—Averaging Type

EDGE (w/GSM), GSM, Service GSM, EDGE mode

```
[[:SENSe]:PVTime:AVERAge:TYPE  
LOG|MAXimum|MINimum|MXMinimum|RMS
```

1xEV-DO mode

```
[[:SENSe]:PVTime:AVERAge:TYPE  
LOG|MAXimum|MINimum|MXMinimum|RMS|SCALar
```

W-CDMA mode

```
[[:SENSe]:PVTime:AVERAge:TYPE RMS|MAXimum|MINimum  
[:SENSe]:PVTime:AVERAge:TYPE?
```

Select the type of averaging to be performed.

LOG - The log of the power is averaged. (This is also known as video averaging.)

MAXimum - The maximum values are retained.

MINimum - The minimum values are retained.

MXMinimum - Both the maximum and the minimum values are

retained. (E4406A - EDGE(W/GSM), GSM, and Service modes, and PSA - GSM, EDGE, and 1xEV-DO modes only)

RMS - The power is averaged to provide a voltage rms value.

SCALar - The amplitude level of power is averaged to provide a voltage value. (1xEV-DO mode only)

Factory Preset: RMS

Remarks: For E4406A you must be in the EDGE(w/GSM), GSM, 1xEV-DO, W-CDMA, or Service mode to use this command. Use INSTRument:SElect to set the mode.

For PSA you must be in the GSM, EDGE, 1xEV-DO, or W-CDMA mode to use this command. Use INSTRument:SElect to set the mode.

Power vs. Time—Resolution BW

```
[ :SENSe ] :PVTTime :BANDwidth | BWIDth [ :RESolution ] <freq>
```

```
[ :SENSe ] :PVTTime :BANDwidth | BWIDth [ :RESolution ] ?
```

Set the resolution bandwidth. This is an advanced control that normally does not need to be changed. Setting this to a value other than the factory default, may cause invalid measurement results.

Factory Preset: 500 kHz 1.5 MHz

5.0 MHz for W-CDMA

Range: 1 kHz to 5 MHz

1.0 kHz to 10.0 MHz when PVT:BAND:RES:TYPE is set to FLATtop

1.0 kHz to 8.0 MHz when PVT:BAND:RES:TYPE is set to GAUSSian

Default Unit: Hz

Remarks: For E4406A you must be in the EDGE(w/GSM), GSM, Service, 1xEV-DO, or W-CDMA mode to use this command. Use INSTRument:SElect to set the mode.

For PSA you must be in the GSM, EDGE, 1xEV-DO, or W-CDMA mode to use this command. Use INSTRument:SElect to set the mode.

Power vs. Time—RBW Filter Type

```
[ :SENSe ] :PVTTime :BANDwidth | BWIDth [ :RESolution ] :TYPE  
FLATtop | GAUSSian
```

`[[:SENSe]:PVTime:BANDwidth|BWIDth[:RESolution]:TYPE?`

Select the type of resolution bandwidth filter. This is an advanced control that normally does not need to be changed. Setting this to a value other than the factory default, may cause invalid measurement results.

FLATtop - a filter with a flat amplitude response, which provides the best amplitude accuracy.

GAUSSian - a filter with Gaussian characteristics, which provides the best pulse response.

Factory Preset: GAUSSian

FLATtop for 1xEV-DO, W-CDMA

Remarks: For E4406A you must be in the EDGE(w/GSM), GSM, Service, 1xEV-DO, or W-CDMA mode to use this command. Use INSTRument:SElect to set the mode.

For PSA you must be in the GSM, EDGE, 1xEV-DO, or W-CDMA mode to use this command. Use INSTRument:SElect to set the mode.

Power vs. Time—Burst Search Threshold

`[[:SENSe]:PVTime:BURSt:STHreshold <rel_power>`

`[[:SENSe]:PVTime:BURSt:STHreshold?`

Specify the relative power threshold level to search for bursts. Use the commands `SENSe:PVTime:BURSt:SLOPe` and `SENSe:PVTime:BURSt:SLOPe:INTEgration:TIME` with this command.

Factory Preset: -10.00 dB

-45 dB for W-CDMA

Range: -100 to 0 dB

Remarks: You must be in the 1xEV-DO or W-CDMA mode to use this command. Use INSTRument:SElect to set the mode.

History: PSA:
Added in version A.02.00

E4406A:
Added in version A.05.00

Power vs. Time—Burst Search Slope

`[[:SENSe]:PVTime:BURSt:SLOPe <number>`

[:SENSE] :PVTime:BURSt:SLOPe?

Specify the minimum slope in the relative power level change per μs , to search for bursts at the specified threshold level.

Factory Preset: 2.0 dB/ μs

Range: 0.1 to 10.0 dB/ μs

Resolution: 0.1 dB/ μs

Remarks: You must be in the 1xEV-DO mode to use this command. Use INSTRUMENT:SELEct to set the mode.

History: PSA:
Added in version A.02.00
E4406A:
Added in version A.05.00

Power vs. Time—Burst Search Slope Time

[:SENSE] :PVTime:BURSt:SLOPe:INTEgration:TIME <number>

[:SENSE] :PVTime:BURSt:SLOPe:INTEgration:TIME?

Specify the integration time in the number of chips, to calculate the minimum slope to search for bursts at the specified threshold level.

Factory Preset: 2.0 chip

Range: 0.5 to 3.0 chip

Resolution: 0.1 chip

Remarks: You must be in the 1xEV-DO mode to use this command. Use INSTRUMENT:SELEct to set the mode.

History: PSA:
Added in version A.02.00
E4406A:
Added in version A.05.00

Power vs. Time—Limit Mask Display

[:SENSE] :PVTime:LIMit:MASK OFF | ON | 0 | 1

[:SENSE] :PVTime:LIMit:MASK?

Show or hide the limit mask. Does not affect the pass/fail calculation for limit tests.

Factory Preset: ON

Remarks: You must be in GSM, EDGE, 1xEV-DO, or W-CDMA

mode to use this command. Use INSTRument:SElect to set the mode.

Power vs. Time—Lower Active Slot Mask Relative Level

```
[ :SENSe ] :PVTime:MASK:ASLot:LOWer:RELative <rel_power>
```

```
[ :SENSe ] :PVTime:MASK:ASLot:LOWer:RELative?
```

Enter the relative power level in the lower limit mask for the active slot.

Factory Preset: -2.5 dB

Range: -100 to +200 dB relative to the reference power

Default Unit: dB

Remarks: You must be in 1xEV-DO mode to use this command.
Use INSTRument:SElect to set the mode.

History: PSA:
Added in version A.02.00

E4406A:
Added in version A.05.00

Power vs. Time—Active Slot Mask Lower Limit Test Mode

```
[ :SENSe ] :PVTime:MASK:ASLot:LOWer:TEST RELative | NONE
```

```
[ :SENSe ] :PVTime:MASK:ASLot:LOWer:TEST?
```

Set the mask to the lower limit test mode relative to the reference power.

Factory Preset: RELative

Range: Only RELative is currently available for the active slot.

Remarks: You must be in 1xEV-DO mode to use this command.
Use INSTRument:SElect to set the mode.

History: PSA:
Added in version A.02.00

E4406A:
Added in version A.05.00

Power vs. Time—Active Slot Mask Time Interval

```
[ :SENSe ] :PVTime:MASK:ASLot:SWEep:TIME <time>
```

`[:SENSE] :PVTime:MASK:ASLot:SWEep:TIME?`

Define the time interval for active slot mask.

Factory Preset: 833.33 μ s

Range: -10 ms to +10 ms

Resolution: 10.0 ns

Remarks: You must be in 1xEV-DO mode to use this command.
Use INSTRument:SElect to set the mode.

History: PSA:
Added in version A.02.00

E4406A:
Added in version A.05.00

Power vs. Time—Active Slot Mask Upper Limit Test Mode

`[:SENSE] :PVTime:MASK:ASLot:UPPer:TEST RELative|NONE`

`[:SENSE] :PVTime:MASK:ASLot:UPPer:TEST?`

Set the mask to the upper limit test mode relative to the reference power.

Factory Preset: RELative

Range: Only RELative is currently available for the active slot mask.

Remarks: You must be in 1xEV-DO mode to use this command.
Use INSTRument:SElect to set the mode.

History: PSA:
Added in version A.02.00

E4406A:
Added in version A.05.00

Power vs. Time—Upper Active Slot Mask Relative Level

`[:SENSE] :PVTime:MASK:ASLot:UPPer:RELative <rel_power>`

`[:SENSE] :PVTime:MASK:ASLot:UPPer:RELative?`

Enter the relative power level in the upper limit mask for the active slot.

Factory Preset: 2.5 dB

Range: -100 to +200 dB relative to the reference power

Default Unit: dB

Remarks: You must be in 1xEV-DO mode to use this command.
Use INSTRument:SElect to set the mode.

History: PSA:
Added in version A.02.00

E4406A:
Added in version A.05.00

Power vs. Time—Lower Mask Relative Amplitude Levels

```
[ :SENSe ] :PVTime:MASK:LIST:LOWer:RELative <rel_power>,  
<rel_power>, <rel_power>, <rel_power>, <rel_power>
```

```
[ :SENSe ] :PVTime:MASK:LIST:LOWer:RELative?
```

Enter the relative power level for each horizontal line segment in the lower limit mask. There should be a power level for each time point entered using [:SENSe] :PVTime:MASK:LIST:LOWer:TIME, and they must be entered in the same order. These power levels are all relative to the defined Reference Power Level (the average power in the useful part of the data). When an upper and lower limit masks have been defined, the Reference Power Level is the mid-point between these two limits at time t0.

Any portion of the signal that has no limit line segment defined for it, will default to a very low limit (–100 dB relative to the reference power). This will keep the measurement from indicating a failure for that portion of the data.

Factory Preset: Selected GSM standard

–100.0, –100.0, –2.5, –100.0, and –100.0 dB for
1xEV-DO

–100.0, –100.0, –1.0, –100.0, and –100.0 dB for
W-CDMA

Range: –100.0 to 200 dB relative to the reference power

Default Unit: dB

Remarks: You must be in GSM, EDGE, 1xEV-DO, or W-CDMA
mode to use this command. Use INSTRument:SElect to
set the mode.

History: E4406A:
Added in revision A.03.00

Power vs. Time—Mask Lower Limit Test Mode

```
[ :SENSe ] :PVTime:MASK:LIST:LOWer:TEST RELative | NONE,
```

,RELative|NONE, RELative|NONE, RELative|NONE, RELative|NONE

[:SENSE] :PVTime:MASK:LIST:LOWer:TEST?

Set the mask to the lower limit test mode.

Factory Preset: NONE, NONE, RELative, NONE, NONE

Range: Only RELative is currently available.

Remarks: You must be in 1xEV-DO or W-CDMA mode to use this command. Use INSTRument:SElect to set the mode.

History: PSA:
Added in version A.02.00

E4406A:
Added in version A.05.00

Power vs. Time—Mask Power Reference

[:SENSE] :PVTime:MASK:PREference A|B|C|D|E

[:SENSE] :PVTime:MASK:PREference?

Select one of the regions to be used as the power reference. If a region is selected, the power in that region is computed and used as the reference power.

Factory Preset: C

Range: A, B, C, D, or E

Remarks: You must be in 1xEV-DO mode to use this command. Use INSTRument:SElect to set the mode.

History: PSA:
Added in version A.02.00

E4406A:
Added in version A.05.00

Power vs. Time—Mask Interval

[:SENSE] :PVTime:MASK:LIST:SWEep:TIME <time>, <time>, <time>, <time>, <time>

[:SENSE] :PVTime:MASK:LIST:SWEep:TIME?

Specify the time interval values of the limit mask.

Factory Preset: 319.34, 7.00, 180.66, 7.00, and 319.34 μ s

Range: -10 ms to +10 ms

Default Unit: seconds

Remarks: You must be in 1xEV-DO mode to use this command.
Use INSTRument:SELEct to set the mode.

History: PSA:
Added in version A.02.00
E4406A:
Added in version A.05.00

Power vs. Time—Mask Time

```
[ :SENSe ] :PVTime:MASK:LIST:TIME <time>, <time>, <time>,  
<time>, <time>
```

```
[ :SENSe ] :PVTime:MASK:LIST:TIME?
```

Specify the starting time points of the limit mask.

Factory Preset: -416.67, -97.33, -90.33, 90.33, and 97.33 μ s

Range: -10 ms to +10 ms

Default Unit: seconds

Remarks: You must be in 1xEV-DO mode to use this command.
Use INSTRument:SELEct to set the mode.

History: PSA:
Added in version A.02.00
E4406A:
Added in version A.05.00

Power vs. Time—Upper Mask Relative Amplitude Levels

```
[ :SENSe ] :PVTime:MASK:LIST:UPPer:RELative <rel_power>,  
<rel_power>, <rel_power>, <rel_power>, <rel_power>
```

```
[ :SENSe ] :PVTime:MASK:LIST:UPPer:RELative?
```

Enter the relative power level for each horizontal line segment in the upper limit mask. There should be a power level for each time point entered using [:SENSe] :PVTime:MASK:LIST:UPPer:TIME, and they must be entered in the same order. These power levels are all relative to the defined Reference Power Level (the average power in the useful part of the data). When an upper and lower limit masks have been defined, the Reference Power Level is the mid-point between these two limits at time t_0 . See [Figure 5-4 on page 453](#).

Figure 5-4 Custom Upper Limit Mask Example

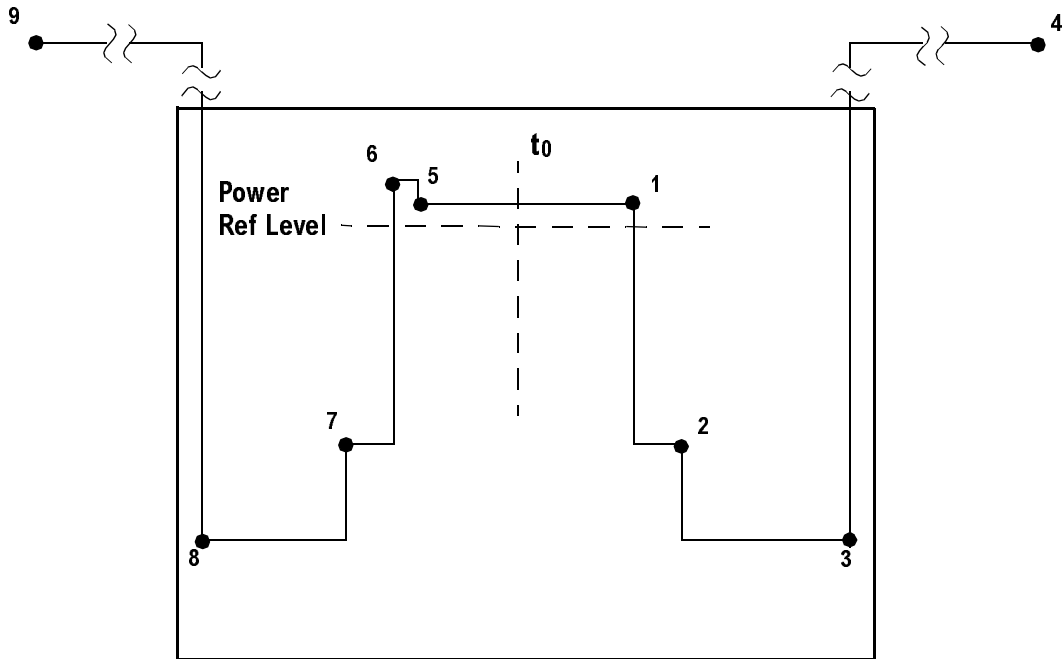

Entered Value for each Time Segment	Absolute Time Value	Relative Power (example with Ref Level = -12 dBm)		Entered Absolute Power (dBm)	Segment Number
		Entered Relative Power	Equivalent Absolute Power		
280.0e-6	280 μ s	+4 dBc	-8 dBm	-200 dBm	1
15.0e-6	295 μ s	-32 dBc	-44 dBm	-200 dBm	2
450.0e-6	745 μ s	-48 dBc	-60 dBm ^a	-58 dBm ^a	3
1	>1 sec	+100 dBc	+112 dBm	-200 dBm	4
-270.0e-6	-270 μ s	+4 dBc	-8 dBm	-200 dBm	5
-10.0e-6	-280 μ s	+7 dBc	-5 dBm	-200 dBm	6
-20.0e-6	-300 μ s	-25 dBc	-37 dBm	-200 dBm	7
-450e-6	-750 μ s	-43 dBc	-55 dBm	-58 dBm	8
-1	<-1 sec	+100 dBc	+112 dBm	-200 dBm	9

a. Notice that this segment, with this value of Ref Level, has a calculated relative level of -60 dBm. This is lower than the specified absolute level of -58 dBm, so the -58 dBm value will be used as the test limit for the segment.

Example: `PVT:MASK:LIST:UPP:REL`

4, -32, -48, 100, 4, 7, -25, -43, 100

Factory Preset: Selected GSM standard

-7.0, 2.5, 2.5, 2.5, and 7.5 dB for 1xEV-DO

-40.0 dB, 2.0 dB, 1.0 dB, 2.0 dB, -40.0 dB for W-CDMA

Range: -100 to +200 dB relative to the reference power

Default Unit: dB

Remarks: You must be in GSM, EDGE, 1xEV-DO, or W-CDMA mode to use this command. Use INSTRUMENT:SElect to set the mode.

History: E4406A:
Added in revision A.03.00

Power vs. Time—Mask Upper Limit Test Mode

```
[ :SENSe ] :PVTime:MASK:LIST:UPPer:TEST RELative | NONE,  
RELative | NONE, RELative | NONE, RELative | NONE, RELative | NONE
```

```
[ :SENSe ] :PVTime:MASK:LIST:UPPer:TEST?
```

Set to the upper limit test mode.

Factory Preset: RELative, RELative, RELative, RELative, RELative

Range: Only RELative is currently available.

Remarks: You must be in 1xEV-DO or W-CDMA mode to use this command. Use INSTRUMENT:SElect to set the mode.

History: PSA:
Added in version A.02.00

E4406A:
Added in version A.05.00

Power vs. Time—Mask Reference Point

```
[ :SENSe ] :PVTime:MASK:REFErence TRIGger | RISE | CENTer
```

```
[ :SENSe ] :PVTime:MASK:REFErence?
```

Define the reference point of the mask timing.

TRIGger - Set to the trigger point.

RISE - Set to the rising edge of the burst determined after acquisition process.

CENTer - Set to the center between the rising and falling edges of the burst determined after acquisition process

Factory Preset: CENTER

RISE for W-CDMA

Remarks: You must be in 1xEV-DO or W-CDMA mode to use this command. Use INSTRUMENT:SElect to set the mode.

History: PSA:
Added in version A.02.00

E4406A:
Added in version A.05.00

Power vs. Time—Mask Reference Point Offset

`[:SENSE] :PVTIME :MASK :REFERENCE [:OFFSET] :TIME <time>`

`[:SENSE] :PVTIME :MASK :REFERENCE [:OFFSET] :TIME?`

Define the time offset of the mask timing reference. This is an advanced control that normally does not need to be changed.

Factory Preset: 0 s

Range: -10 to +10 ms

Remarks: You must be in 1xEV-DO or W-CDMA mode to use this command. Use INSTRUMENT:SElect to set the mode.

History: PSA:
Added in version A.02.00

E4406A:
Added in version A.05.00

Power vs. Time—Slot Type Selection

`[:SENSE] :PVTIME :SLOT [:TYPE] IDLE | ACTIVE`

`[:SENSE] :PVTIME :SLOT [:TYPE] ?`

Set the slot type to either Idle (including Pilot and MAC) or Active (including Pilot, MAC, and Data). Define the reference point of the mask timing.

IDLE - Set to the idle slot that includes the Pilot and MAC channels, of which waveform is bursted.

ACTIVE - Set to the active slot that includes the Pilot, MAC, and Data channels, of which signal is continuous.

Factory Preset: RISE

Remarks: You must be in 1xEV-DO mode to use this command. Use INSTRUMENT:SElect to set the mode.

History: PSA:
 Added in version A.02.00

 E4406A:
 Added in version A.05.00

Power vs. Time—Trigger Source

```
[[:SENSe]:PVTime:TRIGger:SOURce EXTernal [1] | EXTernal2  
| FRAMe | LINE | IF | IMMEDIATE | RFBURSt
```

```
[[:SENSe]:PVTime:TRIGger:SOURce?
```

Select the trigger source used to control the data acquisitions.

EXTernal 1 - front panel external trigger input

EXTernal 2 - rear panel external trigger input

FRAMe - uses the internal frame timer, which has been synchronized to the selected burst sync.

IF - internal IF envelope (video) trigger

LINE - internal power line frequency trigger

IMMEDIATE - the next data acquisition is immediately taken, capturing the signal asynchronously (also called Free Run).

RFBURSt - wideband RF burst envelope trigger that has automatic level control for periodic burst signals.

Factory Preset: RFBURSt if the RF Burst Hardware (option B7E) has been installed

EXTernal, if option B7E has not been installed

FRAMe for 1xEV-DO

Remarks: For E4406A you must be in the EDGE(w/GSM), GSM, Service, 1xEV-DO, or W-CDMA mode to use this command. Use INSTRument:SELEct to set the mode.

For PSA you must be in the GSM, EDGE, 1xEV-DO, or W-CDMA mode to use this command. Use INSTRument:SELEct to set the mode.

Radio Standards Commands

Radio Carrier Multiple

```
[ :SENSE ] :RADio:CARRier:NUMBer SINGLE | MULTiple
```

```
[ :SENSE ] :RADio:CARRier:NUMBer?
```

Select if single or multiple carriers are present on the output of the base station under test. This enables/disables a software filter for the rho and code domain power measurements.

SINGLE – disable software filter.

MULTiple – enable software filter to mitigate the adjacent carrier effects.

Factory Preset: SINGLE

Remarks: You must be in the cdmaOne, cdma2000, 1xEV-DO, or iDEN (E4406A) mode to use this command. Use INSTRUMENT:SELEct to set the mode.

Front Panel

Access: **Mode Setup, Demod, RF Carrier**

Radio Device Under Test

```
[ :SENSE ] :RADio:DEVIce BTS | MS
```

```
[ :SENSE ] :RADio:DEVIce?
```

Select the type of radio device to be tested.

BTS - Base station transmitter test

MS - Mobile station transmitter test

Factory Preset: BTS

Remarks: Global to the current mode.

You must be in cdma2000, GSM, EDGE, W-CDMA or 1xEV-DO mode to use this command. Use INSTRUMENT:SELEct to set the mode.

History: E4406A:
Version A.03.00 or later

Front Panel

Access: **Mode Setup, Radio, Device**

Modulation Accuracy (Rho) Measurement

Commands for querying the rho measurement results and for setting to the default values are found in the “[MEASure Group of Commands](#)” on [page 339](#). The equivalent front panel keys for the parameters described in the following commands, are found under the **Meas Setup** key, after the **Mod Accuracy (Rho)** or **Mod Accuracy (Composite Rho)** measurement has been selected from the **MEASURE** key menu.

Modulation Accuracy – Active Data Channel

```
[ :SENSe ] :RHO:ACODE AUTO | PREDeFined
```

```
[ :SENSe ] :RHO:ACODE?
```

Select the Active Channel ID detection mode Auto or Predefined.

AUTO - detects Active Channel ID for Data Channel automatically.

PREDeFined - set predefined Active Channel (all channel codes) for Data Channel.

Factory Preset: AUTO

Remarks: You must be in the 1xEV-DO mode to use this command. Use INSTRument:SELEct to set the mode.

Modulation Accuracy (Rho) Measurement — ADC Range

```
[ :SENSe ] :RHO:ADC:RANGe
```

```
AUTO | APEak | APLock | NONE | M6 | P0 | P6 | P12 | P18 | P24
```

```
[ :SENSe ] :RHO:ADC:RANGe?
```

Select a ranging function for the ADC gain control. This is an advanced control that normally does not need to be changed. If you are measuring a CW signal, see the following description:

- AUTO - automatic ranging
For FFT spectrums, the auto ranging should not be used. An exception to this would be if you know that your signal is “bursty”. Then you might use auto to maximize the time domain dynamic range as long as you are not very interested in the FFT data.
- APEak (Auto Peak) - automatic ranging to the peak signal level
For CW signals, the default of auto-peak ranging can be used, but a better FFT measurement of the signal can be made by selecting one of the manual ranges that is available by specifying M6, or P0 through P24.

Auto peaking can cause the ADC gain to monotonically track the ranges down during the data capture. This tracking effect should be negligible for the FFT spectrum, but selecting a manual range solves

this possibility. Note that if the CW signal being measured is close to the auto-ranging threshold, the noise floor may shift as much as 6 dB every sweep.

- APLOCK (Auto Peak Lock) - automatic ranging locked to the peak signal level

For CW signals, auto-peak lock ranging may be used. It will find the ADC gain most appropriate for this particular signal and will not track the ranges as auto-peak can. Note that if the CW signal being measured is close to the auto-ranging threshold, the noise floor may shift as much as 6 dB every sweep.

For “bursty” signals, auto-peak lock ranging should not be used. Since the ADC range can often be locked to the wrong one resulting in overloading the ADC, the measurement will fail.

- NONE - turns off any auto-ranging without making any changes to the current setting.
- M6 - manually selects an ADC range that subtracts 6 dB from the fixed gain across the range. Manual ranging is best for CW signals.
- P0 thru P24 - manually selects one of the ADC ranges that add 0 dB to 24 dB to the fixed gain across the range. Manual ranging is best for CW signals.

Factory Preset: M6

Remarks: You must be in the 1xEV-DO mode to use this command. Use INSTRUMENT:SElect to set the mode.

Modulation Accuracy (Rho)—Average Count

`[:SENSe] :RHO:AVERAge:COUNT <integer>`

`[:SENSe] :RHO:AVERAge:COUNT?`

Set the number of data acquisitions that will be averaged. After the specified number of averaging counts, the averaging mode (termination control) setting determines the averaging action.

Factory Preset: 10

Range: 1 to 10,000

Remarks: You must be in the cdmaOne, cdma2000, W-CDMA, or 1xEV-DO mode to use this command. Use INSTRUMENT:SElect to set the mode.

Modulation Accuracy (Rho)—Averaging State

`[:SENSe] :RHO:AVERAge [:STATe] OFF | ON | 0 | 1`

`[:SENSe] :RHO:AVERAge [:STATe] ?`

Turn the modulation accuracy averaging function on or off.

Factory Preset: OFF

ON for cdma2000, W-CDMA, 1xEV-DO

Remarks: You must be in the cdmaOne, cdma2000, W-CDMA, or 1xEV-DO mode to use this command. Use INSTRument:SElect to set the mode.

Modulation Accuracy (Rho)—Averaging Termination Control

`[:SENSe] :RHO:AVERAge:TCONTRol EXPonential | REPeat`

`[:SENSe] :RHO:AVERAge:TCONTRol?`

Select the type of termination control used for the averaging function. This determines the averaging action after the specified number of frames (average count) is reached.

EXPonential - Each successive data acquisition after the average count is reached, is exponentially weighted and combined with the existing average.

REPeat - After reaching the average count, the averaging is reset and a new average is started.

Factory Preset: REPeat for cdmaOne, cdma2000, W-CDMA, 1xEV-DO

Remarks: You must be in the cdmaOne, cdma2000, W-CDMA, or 1xEV-DO mode to use this command. Use INSTRument:SElect to set the mode.

Modulation Accuracy (Rho)—Chip Rate

`[:SENSe] :RHO:CRATe <freq>`

`[:SENSe] :RHO:CRATe?`

Enter a frequency value to set the chip rate.

Factory Preset: 1.2288 MHz for cdma2000, 1xEV-DO

3.84 MHz for W-CDMA

Range: 1.10592 to 1.35168 MHz for cdma2000, 1xEV-DO

3.456 to 4.224 MHz for W-CDMA

Default Unit: Hz

Remarks: You must be in the cdma2000, W-CDMA, or 1xEV-DO

mode to use this command. Use INSTRUMENT:SElect to set the mode.

Modulation Accuracy (Rho)—Multi Carrier Estimator

[:SENSE] :RHO:MCEstimator OFF | ON | 0 | 1

[:SENSE] :RHO:MCEstimator?

Turns the multi carrier estimator on or off.

OFF - computes the phase information only from one coded signal assuming that each code phase is perfectly aligned.

ON - aligns the code phases to be orthogonal before computing the phase information.

Factory Preset: OFF

Remarks: You must be in the cdma2000, W-CDMA, or 1xEV-DO mode to use this command. Use INSTRUMENT:SElect to set the mode.

Modulation Accuracy (Rho)—PN Offset

[:SENSE] :RHO:PNOffset <integer>

[:SENSE] :RHO:PNOffset?

Set a PN sequence number for the base station being tested. This value behaves as a multiplier for the Walsh codes of which length is in the unit of 64 chips.

Factory Preset: 0

Range: 0 to 511

Unit: 64 chips

Remarks: You must be in the 1xEV-DO mode to use this command. Use INSTRUMENT:SElect to set the mode.

Modulation Accuracy (Rho)—Preamble Length

[:SENSE] :RHO:PREamble:LENGth <integer>

[:SENSE] :RHO:PREamble:LENGth?

Set the Preamble length manually in chips.

Factory Preset: 0

Range: 0, 64, 128, 256, 512 and 1024

Remarks: You must be in the 1xEV-DO mode to use this command. Use INSTRument:SElect to set the mode.

Modulation Accuracy (Rho)—Preamble Auto Detection

```
[ :SENSe ] :RHO:PREamble:LENGth:AUTO OFF | ON | 0 | 1
```

```
[ :SENSe ] :RHO:PREamble:LENGth:AUTO?
```

Turn the Preamble Length detection mode on or off.

On - detects the Preamble length automatically.

Off - sets the Preamble length manually by
[:SENSe]:RHO:PREamble:LENGth.

Factory Preset: ON

Remarks: You must be in the 1xEV-DO mode to use this command. Use INSTRument:SElect to set the mode.

Modulation Accuracy (Rho)—Rho Overall Preamble Included

```
[ :SENSe ] :RHO:PREamble:STATE OFF | ON | 0 | 1
```

```
[ :SENSe ] :RHO:PREamble:STATE?
```

Select whether or not Preamble is included for Rho Overall calculation.

On – Preamble chips is included for Rho Overall calculation

Off – Preamble chips is Not included for Rho Overall calculation.

Factory Preset: ON

Remarks: You must be in the 1xEV-DO mode to use this command. Use INSTRument:SElect to set the mode.

Modulation Accuracy (Rho)—Spectrum Normal/Invert

```
[ :SENSe ] :RHO:SPECTrum INVert | NORMal
```

```
[ :SENSe ] :RHO:SPECTrum?
```

Set a spectrum either to normal or inverted for the demodulation related measurements. If set to INVert, the upper and lower spectrums are swapped.

Factory Preset: NORMal

Remarks You must be in the cdmaOne, cdma2000, W-CDMA, or 1xEV-DO mode to use this command. Use INSTRument:SElect to set the mode.

Modulation Accuracy (Rho)—Trigger Source

```
[ :SENSE] :RHO:TRIGger:SOURce  
EXTernal [1] | External2 | FRAME | IF | IMMEDIATE | RFBURSt  
[ :SENSE] :RHO:TRIGger:SOURce?
```

Select the trigger source used to control the data acquisitions.

EXTernal 1 – front panel external trigger input

EXTernal 2 – rear panel external trigger input

FRAME – internal frame trigger

IF – internal IF envelope (video) trigger

IMMEDIATE – the next data acquisition is immediately taken, capturing the signal asynchronously (also called free run).

RFBURSt – internal wideband RF burst envelope trigger that has automatic level control for periodic burst signals.

Factory Preset: IMMEDIATE

Remarks: You must be in the cdmaOne, cdma2000, W-CDMA, or 1xEV-DO mode to use this command. Use INSTRUMENT:SELECT to set the mode.

Front Panel

Access: Meas Setup, Trig Source

Spectrum Emission Mask Measurement

Commands for querying the Spectrum Emission Mask measurement results and for setting to the default values are found in the “[MEASure Group of Commands](#)” on page 339. The equivalent front panel keys for the parameters described in the following commands, are found under the **Meas Setup** key, after selecting the measurement from the **MEASURE** key menu. Select the **Spectrum Emission Mask** measurement (for W-CDMA, cdma2000) or the **Spurious Emissions and ACP** measurement (for 1xEV-DO).

History: E4406A:
Added version A.04.00 and later

Spectrum Emission Mask—Average Count

`[:SENSe] :SEMAsk:AVERAge:COUNT <integer>`

`[:SENSe] :SEMAsk:AVERAge:COUNT?`

Set the number of data acquisitions that will be averaged. After the specified number of average count, the average mode (termination control) setting determines the average action.

Factory Preset: 10

Range: 1 to 10,000

Remarks: You must be in the cdma2000, W-CDMA, or 1xEV-DO mode to use this command. Use `INSTRument:SElect` to set the mode.

Spectrum Emission Mask—Averaging State

`[:SENSe] :SEMAsk:AVERAge [:STATe] OFF | ON | 0 | 1`

`[:SENSe] :SEMAsk:AVERAge [:STATe] ?`

Turn the averaging function On or Off.

Factory Preset: OFF

Remarks: You must be in the cdma2000, W-CDMA, or 1xEV-DO mode to use this command. Use `INSTRument:SElect` to set the mode.

Spectrum Emission Mask—Averaging Termination Control

`[:SENSe] :SEMAsk:AVERAge:TCONTRol EXPonential | REPEAT`

`[:SENSe] :SEMAsk:AVERAge:TCONTRol?`

Select the type of termination control used for averaging. This

determines the averaging action after the specified number of data acquisitions (average count) is reached.

EXPOnential - Each successive data acquisitions after the average count is reached is exponentially weighted and combined with the existing average.

REPeat - After reaching the average count, the averaging is reset and a new average is started.

Factory Preset: EXPOnential

Remarks: You must be in the 1xEV-DO mode to use this command. Use INSTRUMENT:SElect to set the mode.

Spectrum Emission Mask—Reference Channel Integration Bandwidth

cdma2000, W-CDMA mode

[:SENSE] :SEMAsk:BANDwidth [n] | BWIDth [n] :INTEgration <freq>

[:SENSE] :SEMAsk:BANDwidth [n] | BWIDth [n] :INTEgration?

1xEV-DO mode

[:SENSE] :SEMAsk:BANDwidth | BWIDth:INTEgration [m] <freq>

[:SENSE] :SEMAsk:BANDwidth | BWIDth:INTEgration [m] ?

Set the integration bandwidth that will be used for the reference channel.

BANDwidth [n] | BWIDth [n]

n=1 is the base station test and n=2 is the mobile station test. The default is the base station test (1).
(cdma2000, W-CDMA mode only)

INTEgration [m] m=1 is the spectrum emission mask (SEM) mode and m=2 is the adjacent channel power (ACP) mode. The default is the SEM mode (1). (1xEV-DO mode only)

Factory Preset: 1.23 MHz for cdma2000, 1xEV-DO

3.84 MHz for W-CDMA

Range: 100.0 kHz to 1.250 MHz

Default Unit: Hz

Remarks: You must be in the cdma2000, W-CDMA, or 1xEV-DO mode to use this command. Use INSTRUMENT:SElect to set the mode.

Spectrum Emission Mask—Reference Channel Resolution Bandwidth

cdma2000, W-CDMA mode

```
[[:SENSe]:SEMAsk:BANDwidth[n] | BWIDth[n]:RESolution <freq>
```

```
[[:SENSe]:SEMAsk:BANDwidth[n] | BWIDth[n]:RESolution?
```

1xEV-DO mode

```
[[:SENSe]:SEMAsk:BANDwidth | BWIDth:RESolution [m] <freq>
```

```
[[:SENSe]:SEMAsk:BANDwidth | BWIDth:RESolution [m] ?
```

Set the resolution bandwidth for the reference channel.

BANDwidth[n] | BWIDth[n]

n=1 is the base station test and n=2 is the mobile station test. The default is the base station test (1). (cdma2000, W-CDMA mode only)

RESolution[m] m=1 is the spectrum emission mask (SEM) mode and m=2 is the adjacent channel power (ACP) mode. The default is the SEM mode (1). (1xEV-DO mode only)

Factory Preset: No valid value as the default is set to Auto. See [:SENS]:SEM:BAND[n] | BWID[n]:RES[m]:AUTO.

Range: 1.0 kHz to 7.5 MHz

Default Unit: Hz

Remarks: You must be in the cdma2000, W-CDMA, or 1xEV-DO mode to use this command. Use INSTRument:SElect to set the mode.

Spectrum Emission Mask—Auto Mode for Reference Channel Resolution Bandwidth

cdma2000, W-CDMA mode

```
[[:SENSe]:SEMAsk:BANDwidth[n] | BWIDth[n]:RESolution:AUTO  
OFF | ON | 0 | 1
```

```
[[:SENSe]:SEMAsk:BANDwidth[n] | BWIDth[n]:RESolution:AUTO?
```

1xEV-DO mode

```
[[:SENSe]:SEMAsk:BANDwidth | BWIDth:RESolution [m] :AUTO  
OFF | ON | 0 | 1
```

```
[[:SENSe]:SEMAsk:BANDwidth | BWIDth:RESolution [m] :AUTO?
```

Set the auto mode to determine the resolution bandwidth to On or Off. If set to Off, enter a frequency value referring to [:SENS]:SEM:BAND[n] | BWID[n]:RES[m].

BANDwidth[n] | BWIDth[n]

n=1 is the base station test and n=2 is the mobile station test. The default is the base station test (1). (cdma2000, W-CDMA mode only)

RESolution[m] m=1 is the spectrum emission mask (SEM) mode and m=2 is the adjacent channel power (ACP) mode. The default is the SEM mode (1). (1xEV-DO mode only)

Factory Preset: ON

Remarks: You must be in the cdma2000, W-CDMA, or 1xEV-DO mode to use this command. Use INSTRUMENT:SElect to set the mode.

Spectrum Emission Mask—Detector Mode

[:SENSE] :SEMAsk:DETector [:FUNction] AAVerage | POSitive

[:SENSE] :SEMAsk:DETector [:FUNction] ?

Select one of the detector modes for spectrum measurements.

AAVerage (absolute average) - the absolute average power in each frequency is measured across the spectrum

POSitive - the positive peak power in each frequency is measured across the spectrum

Factory Preset: AAVerage (absolute average)

Remarks: You must be in the cdma2000, W-CDMA, or 1xEV-DO mode to use this command. Use INSTRUMENT:SElect to set the mode.

Spectrum Emission Mask—Channel Frequency Span

[:SENSE] :SEMAsk:FREQuency [n] :SPAN [m] <freq>

[:SENSE] :SEMAsk:FREQuency [n] :SPAN [m] ?

Enter a frequency value to set the channel frequency span for the reference channel integration.

FREQuency[n] n=1 is the base station test and n=2 is the mobile test. The default is the base station test (1). (cdma2000, W-CDMA mode only)

SPAN[m] m=1 is the spectrum emission mask (SEM) mode and m=2 is the adjacent channel power (ACP) mode. The default is the SEM mode (1). (1xEV-DO mode only)

Factory Preset: 1.25 MHz for cdma2000, 1xEV-DO

5.0 MHz for W-CDMA
Range: 100.0 kHz to 10.0 MHz
Remarks: You must be in the cdma2000, W-CDMA, or 1xEV-DO mode to use this command. Use INSTRument:SElect to set the mode.

Spectrum Emission Mask—Reference Channel Step Frequency

cdma2000, W-CDMA mode

```
[ :SENSe ] :SEMAsk:FREQuency [n] :STEP <freq>
```

```
[ :SENSe ] :SEMAsk:FREQuency [n] :STEP?
```

1xEV-DO mode

```
[ :SENSe ] :SEMAsk:FREQuency:STEP [m] <freq>
```

```
[ :SENSe ] :SEMAsk:FREQuency:STEP [m] ?
```

Enter a frequency value to set the step frequency for the reference channel integration.

FREQuency[n] n=1 is the base station test and n=2 is the mobile test. The default is the base station test (1). (cdma2000, W-CDMA mode only)

STEP[m] m=1 is the spectrum emission mask (SEM) mode and m=2 is the adjacent channel power (ACP) mode. The default is the SEM mode (1). (1xEV-DO mode only)

Factory Preset: No valid value as the default is set to Auto. See [:SENS]:SEM:FREQ[n]:STEP[m]:AUTO.

Range: 100 Hz to 7.5 MHz

Remarks: You must be in the cdma2000, W-CDMA, or 1xEV-DO mode to use this command. Use INSTRument:SElect to set the mode.

Spectrum Emission Mask—Auto Mode for Reference Channel Step Frequency

cdma2000, W-CDMA mode

```
[ :SENSe ] :SEMAsk:FREQuency [n] :STEP:AUTO OFF | ON | 0 | 1
```

```
[ :SENSe ] :SEMAsk:FREQuency [n] :STEP:AUTO?
```

1xEV-DO mode

```
[ :SENSe ] :SEMAsk:FREQuency:STEP [m] :AUTO OFF | ON | 0 | 1
```

[:SENSe] :SEMAsk:FREQuency:STEP [m] :AUTO?

Set the auto mode to determine the step frequency to On or Off.

OFF - enter a value to set the step frequency for the reference channel integration, referring to [:SENS]:SEM:FREQ[n]:STEP[m].

ON - the step frequency for the reference channel integration is set to a half of the resolution bandwidth.

FREQuency[n] n=1 is the base station test and n=2 is the mobile test. The default is the base station test (1). (cdma2000, W-CDMA mode only)

STEP[m] m=1 is the spectrum emission mask (SEM) mode and m=2 is the adjacent channel power (ACP) mode. The default is the SEM mode (1). (1xEV-DO mode only)

Factory Preset: ON

Remarks: You must be in the cdma2000, W-CDMA, or 1xEV-DO mode to use this command. Use INSTRument:SElect to set the mode.

Spectrum Emission Mask—Offset Resolution Bandwidth

cdma2000, W-CDMA mode

**[:SENSe] :SEMAsk:OFFSet [n] :LIST:BANDwidth | BWIDTh
<res_bw>, <res_bw>, <res_bw>, <res_bw>, <res_bw>**

[:SENSe] :SEMAsk:OFFSet [n] :LIST:BANDwidth | BWIDTh?

1xEV-DO mode

**[:SENSe] :SEMAsk:OFFSet:LIST [m] :BANDwidth | BWIDTh
<res_bw>, <res_bw>, <res_bw>, <res_bw>, <res_bw>**

[:SENSe] :SEMAsk:OFFSet:LIST [m] :BANDwidth | BWIDTh?

Define the offset resolution bandwidth for Spectrum Emission Mask measurements. The list must contain five (5) entries. You can turn off (not use) specific offsets with [:SENS]:SEM:OFFS[n]:LIST[m]:STAT.

OFFSet[n] n=1 is the base station test and n=2 is the mobile test. The default is the base station test (1). (cdma2000, W-CDMA only)

LIST[m] m=1 is the spectrum emission mask (SEM) mode and m=2 is the adjacent channel power (ACP) mode. The default is the SEM mode (1). (1xEV-DO mode only)

Factory Preset:

Mode	Variant	Offset A	Offset B	Offset C	Offset D	Offset E
cdma2000	BTS	3.00 kHz	30.00 kHz	30.0 kHz	6.25 kHz	1.000 MHz
	MS	30.00 kHz	30.00 kHz	6.25 kHz	1.000 MHz	1.000 MHz
W-CDMA	BTS	30.00 kHz	30.00 kHz	30.00 kHz	50.00 kHz	1.000 MHz
	MS	30.00 kHz	1.000 MHz	1.000 MHz	1.000 MHz	1.000 MHz
1xEV-DO	SEM	3.000 kHz	30.00 kHz	30.00 kHz	6.250 kHz	1.000 MHz
	ACP	3.000 kHz	30.00 kHz	30.00 kHz	30.00 kHz	30.00 kHz

Range: 300 Hz to 7.5 MHz

Default Unit: Hz

Remarks: You must be in the cdma2000, W-CDMA, or 1xEV-DO mode to use this command. Use INSTRument:SElect to set the mode.

Spectrum Emission Mask—Auto Offset Resolution Bandwidth

cdma2000, W-CDMA mode

```
[[:SENSe]:SEMAsk:OFFSet [n]:LIST:BA NDwidth|BWIDth:AUTO  
OFF|ON|0|1,OFF|ON|0|1,OFF|ON|0|1,OFF|ON|0|1,OFF|ON|0|1
```

```
[[:SENSe]:SEMAsk:OFFSet [n]:LIST:BA NDwidth|BWIDth:AUTO?
```

1xEV-DO mode

```
[[:SENSe]:SEMAsk:OFFSet:LIST [m]:BA NDwidth|BWIDth:AUTO  
OFF|ON|0|1,OFF|ON|0|1,OFF|ON|0|1,OFF|ON|0|1,OFF|ON|0|1
```

```
[[:SENSe]:SEMAsk:OFFSet:LIST [m]:BA NDwidth|BWIDth:AUTO?
```

Set the auto mode to determine the offset resolution bandwidth to On or Off.

OFF - enter a value to set the resolution bandwidth for an offset channel, referring to [:SENS]:SEM:OFFS[n]:LIST[m]BAND|BWID.

ON - the resolution bandwidth for an offset channel is automatically set according to the offset start and stop frequencies.

OFFSet[n] n=1 is the base station test and n=2 is the mobile test. The default is the base station test (1). (cdma2000, W-CDMA mode only)

LIST[m] m=1 is the spectrum emission mask (SEM) mode and m=2 is the adjacent channel power (ACP) mode. The default is the SEM mode (1). (1xEV-DO mode only)

Factory Preset and *RST:

Mode	Variant	Offset A	Offset B	Offset C	Offset D	Offset E
cdma2000		OFF	OFF	OFF	OFF	OFF
W-CDMA		OFF	OFF	OFF	OFF	OFF
1xEV-DO	SEM	OFF	OFF	OFF	OFF	OFF
	ACP	OFF	OFF	OFF	OFF	OFF

Remarks: You must be in the cdma2000, W-CDMA, or 1xEV-DO mode to use this command. Use INSTRUMENT:SElect to set the mode.

Spectrum Emission Mask—Offset Resolution Bandwidth Multiplier

cdma2000, W-CDMA mode

```
[ :SENSE ] :SEMAsk:OFFSet [n] :LIST:BANDwidth | BWIDTh:IMULti
<integer>, <integer>, <integer>, <integer>, <integer>
```

```
[ :SENSE ] :SEMAsk:OFFSet [n] :LIST:BANDwidth | BWIDTh:IMULti?
```

1xEV-DO mode

```
[ :SENSE ] :SEMAsk:OFFSet:LIST [m] :BANDwidth | BWIDTh:IMULti
<integer>, <integer>, <integer>, <integer>, <integer>
```

```
[ :SENSE ] :SEMAsk:OFFSet:LIST [m] :BANDwidth | BWIDTh:IMULti?
```

Specify a multiplier of the offset resolution bandwidth for the offset measurement integration bandwidth.

OFFSet[n] n=1 is the base station test and n=2 is the mobile test. The default is the base station test (1). (cdma2000, W-CDMA mode only)

LIST[m] m=1 is the spectrum emission mask (SEM) mode and m=2 is the adjacent channel power (ACP) mode. The default is the SEM mode (1). (1xEV-DO mode only)

Factory Preset:

Mode	Variant	Offset A	Offset B	Offset C	Offset D	Offset E
cdma2000	BTS	10	1	1	1	1
	MS	1	1	1	1	1
W-CDMA	BTS	1	1	1	20	1
	MS	1	1	1	1	1

Mode	Variant	Offset A	Offset B	Offset C	Offset D	Offset E
1xEV-DO	SEM	10	1	1	1	1
	ACP	10	1	1	1	1

Range: 1 to ((Stop frequency – Start frequency) / Resolution bandwidth)

Remarks: You must be in the cdma2000, W-CDMA, or 1xEV-DO mode to use this command. Use INSTRument:SElect to set the mode.

Spectrum Emission Mask—Offset Start Frequency

cdma2000, W-CDMA mode

```
[ :SENSe ] :SEMask:OFFSet [n] :LIST:FREQuency:START
<f_offset>, <f_offset>, <f_offset>, <f_offset>, <f_offset>
```

```
[ :SENSe ] :SEMask:OFFSet [n] :LIST:FREQuency:START?
```

1xEV-DO mode

```
[ :SENSe ] :SEMask:OFFSet:LIST [m] :FREQuency:START
<f_offset>, <f_offset>, <f_offset>, <f_offset>, <f_offset>
```

```
[ :SENSe ] :SEMask:OFFSet:LIST [m] :FREQuency:START?
```

Set the five (5) sets of the offset start frequencies.

OFFSet[n] n=1 is the base station test and n=2 is the mobile test. The default is the base station test (1). (cdma2000, W-CDMA mode only)

LIST[m] m=1 is the spectrum emission mask (SEM) mode and m=2 is the adjacent channel power (ACP) mode. The default is the SEM mode (1). (1xEV-DO mode only)

Factory Preset:

Mode	Variant	Offset A	Offset B	Offset C	Offset D	Offset E
cdma2000	BTS	765.0 kHz	795.0 kHz	1.195 MHz	3.2531 MHz	7.500 MHz
	MS	900.0 kHz	1.995 MHz	2.2531 MHz	8.500 MHz	12.50 MHz
W-CDMA	BTS	2.515 MHz	2.715 MHz	3.515 MHz	4.000 MHz	8.000 MHz
	MS	2.515 MHz	4.000 MHz	7.500 MHz	8.5 00MHz	12.50 MHz
1xEV-DO	SEM	765.0 kHz	795.0 kHz	1.995 MHz	3.2531 MHz	7.500 MHz
	ACP	765.0 kHz	1.995 MHz	3.125 MHz	4.000 MHz	7.500 MHz

Range: 10.0 kHz to 100.0 MHz
 Default Unit: Hz
 Remarks: You must be in the cdma2000, W-CDMA, or 1xEV-DO mode to use this command. Use INSTRUMENT:SElect to set the mode.

Spectrum Emission Mask—Offset Step Frequency

cdma2000, W-CDMA mode

```
[ :SENSE ] :SEMAsk:OFFSet [n] :LIST:FREQuency:STEP
<f_offset>,<f_offset>,<f_offset>,<f_offset>,<f_offset>
[ :SENSe ] :SEMAsk:OFFSet [n] :LIST:FREQuency:STEP?
```

1xEV-DO mode

```
[ :SENSE ] :SEMAsk:OFFSet:LIST [m] :FREQuency:STEP
<f_offset>,<f_offset>,<f_offset>,<f_offset>,<f_offset>
[ :SENSe ] :SEMAsk:OFFSet:LIST [m] :FREQuency:STEP?
```

Set the five (5) sets of the offset step frequencies.

OFFSet[n] n=1 is the base station test and n=2 is the mobile test. The default is the base station test (1). (cdma2000, W-CDMA mode only)

LIST[m] m=1 is the spectrum emission mask (SEM) mode and m=2 is the adjacent channel power (ACP) mode. The default is the SEM mode (1). (1xEV-DO mode only)

Factory Preset: No valid value as the default is set to Auto. See [:SENS]:SEM:OFF[n]:LIST[m]:FREQ:STEP:AUTO.

Range: 100 Hz to 7.5 MHz
 The minimum value is determined to be equal to or greater than one 2000th (1/2000) of the frequency difference derived from (Stop Freq – Start Freq).

Default Unit: Hz

Remarks: You must be in the cdma2000, W-CDMA, or 1xEV-DO mode to use this command. Use INSTRUMENT:SElect to set the mode.

Spectrum Emission Mask—Auto Offset Step Frequency

cdma2000, W-CDMA mode

```
[ :SENSE ] :SEMAsk:OFFSet [n] :LIST:FREQuency:STEP:AUTO
```

OFF|ON|0|1, OFF|ON|0|1, OFF|ON|0|1, OFF|ON|0|1, OFF|ON|0|1

[:SENSe] :SEMAsk:OFFSet [n] :LIST:FREQuency:STEP:AUTO?

1xEV-DO mode

[:SENSe] :SEMAsk:OFFSet:LIST [m] :FREQuency:STEP:AUTO
OFF|ON|0|1, OFF|ON|0|1, OFF|ON|0|1, OFF|ON|0|1, OFF|ON|0|1

[:SENSe] :SEMAsk:OFFSet:LIST [m] :FREQuency:STEP:AUTO?

Set the auto mode to determine the offset step frequency to On or Off.

OFF - enter a value to set the step frequency for an offset channel, referring to [:SENS]:SEM:OFFS[n]:LIST[m]:FREQ:STEP.

ON - the step frequency for an offset channel is automatically set according to the offset start and stop frequencies.

OFFSet[n] n=1 is the base station test and n=2 is the mobile test. The default is the base station test (1). (cdma2000, W-CDMA mode only)

LIST[m] m=1 is the spectrum emission mask (SEM) mode and m=2 is the adjacent channel power (ACP) mode. The default is the SEM mode (1). (1xEV-DO mode only)

Factory Preset:

Mode	Variant	Offset A	Offset B	Offset C	Offset D	Offset E
cdma2000		ON	ON	ON	ON	ON
W-CDMA		ON	ON	ON	ON	ON
1xEV-DO	SEM	ON	ON	ON	ON	ON
	ACP	ON	ON	ON	ON	ON

Remarks: You must be in cdma2000, W-CDMA, or 1xEV-DO mode to use this command. Use INSTRument:SElect to set the mode.

Spectrum Emission Mask—Offset Stop Frequency

cdma2000, W-CDMA mode

[:SENSe] :SEMAsk:OFFSet [n] :LIST:FREQuency:STOP
<f_offset>, <f_offset>, <f_offset>, <f_offset>, <f_offset>

[:SENSe] :SEMAsk:OFFSet [n] :LIST:FREQuency:STOP?

1xEV-DO mode

[:SENSe] :SEMAsk:OFFSet:LIST [m] :FREQuency:STOP
<f_offset>, <f_offset>, <f_offset>, <f_offset>, <f_offset>

[:SENSE] :SEMask:OFFSet:LIST [m] :FREQuency:STOP?

Sets the five (5) sets of the offset stop frequencies.

OFFSet[n] n=1 is the base station test and n=2 is the mobile test.
The default is the base station test (1). (cdma2000,
W-CDMA mode only)

LIST[m] m=1 is the spectrum emission mask (SEM) mode and
m=2 is the adjacent channel power (ACP) mode. The
default is the SEM mode (1). (1xEV-DO mode only)

Factory Preset:

Mode	Variant	Offset A	Offset B	Offset C	Offset D	Offset E
cdma2000	BTS	795.0 kHz	1.195 MHz	4.015 MHz	4.0031 MHz	12.50 MHz
	MS	1.995 MHz	4.015 MHz	4.0031 MHz	12.00 MHz	15.00 MHz
W-CDMA	BTS	2.715 MHz	3.515 MHz	4.000 MHz	8.000 MHz	12.50 MHz
	MS	3.485 MHz	7.500 MHz	8.500 MHz	12.00 MHz	15.00 MHz
1xEV-DO	SEM	795.0 kHz	1.995 MHz	4.015 MHz	4.0031 MHz	12.50 MHz
	ACP	765.0 kHz	1.995 MHz	3.125 MHz	4.000 MHz	7.500 MHz

Range: 10.0 kHz to 100.0 MHz

Default Unit: Hz

Remarks: You must be in the cdma2000, W-CDMA, or 1xEV-DO
mode to use this command. Use INSTRument:SElect
to set the mode.

Spectrum Emission Mask—Offset Relative Attenuation

cdma2000, W-CDMA mode

**[:SENSE] :SEMask:OFFSet [n] :LIST:RATTenuation
<rel_power>,<rel_power>,<rel_power>,<rel_power>,<rel_power>**

[:SENSE] :SEMask:OFFSet [n] :LIST:RATTenuation?

1xEV-DO mode

**[:SENSE] :SEMask:OFFSet:LIST [m] :RATTenuation
<rel_power>,<rel_power>,<rel_power>,<rel_power>,<rel_power>**

[:SENSE] :SEMask:OFFSet:LIST [m] :RATTenuation?

Set a relative amount of attenuation for the measurements made at an offset channel. The amount is specified relative to the attenuation required to measure the carrier channel. Since the offset channel power is lower than the carrier channel power, less attenuation is required to

measure the offset channel and you get wider dynamic range for the measurement.

You can turn off (not use) specific offset channels with
[:SENS]:SEM:OFFS[n]:LIST[m]:STAT.

OFFSet[n] n=1 is the base station test and n=2 is the mobile test.
The default is the base station test (1). (cdma2000,
W-CDMA mode only)

LIST[m] m=1 is the spectrum emission mask (SEM) mode and
m=2 is the adjacent channel power (ACP) mode. The
default is the SEM mode (1). (1xEV-DO mode only)

Factory Preset:

Mode	Offset A	Offset B	Offset C	Offset D	Offset E
cdma2000	0.00 dB	0.00 dB	0.00 dB	0.00 dB	0.00 dB
W-CDMA	0.00 dB	0.00 dB	0.00 dB	0.00 dB	0.00 dB
1xEV-DO	0.00 dB	0.00 dB	0.00 dB	0.00 dB	0.00 dB

Range: -40.00 to 0.00 dB, but this relative attenuation cannot
exceed the absolute attenuation ranging from 0 to 40
dB.

Default Unit: dB

Remarks: Remember that the attenuation that you specify is
always relative to the amount of attenuation used for
the carrier channel. Selecting negative attenuation
means that you want less attenuation used. For
example, if the measurement must use 20 dB of
attenuation for the carrier measurement and you want
to use 12 dB less attenuation for the first offset, you
would send the value -12 dB.

You must be in the cdma2000, W-CDMA, or 1xEV-DO
mode to use this command. Use INSTRument:SElect to
set the mode.

Spectrum Emission Mask—Offset Frequency Side

cdma2000, W-CDMA mode

```
[:SENSe]:SEMAsk:OFFSet [n]:LIST:SIDE BOTH|NEGAtive|POSitive,  
BOTH|NEGAtive|POSitive,BOTH|NEGAtive|POSitive,  
BOTH|NEGAtive|POSitive,BOTH|NEGAtive|POSitive
```

```
[:SENSe]:SEMAsk:OFFSet [n]:LIST:SIDE?
```

1xEV-DO mode

```
[ :SENSe] :SEMAsk:OFFSet:LIST [m] :SIDE BOTH | NEGAtive | POSitive,
BOTH | NEGAtive | POSitive, BOTH | NEGAtive | POSitive,
BOTH | NEGAtive | POSitive, BOTH | NEGAtive | POSitive
```

```
[ :SENSe] :SEMAsk:OFFSet:LIST [m] :SIDE?
```

Specify which sideband will be measured. You can turn off (not use) specific offsets with [:SENS]:SEM:OFFS[n]:LIST[m]:STAT.

BOTH - both of the negative (lower) and positive (upper) sidebands

NEGAtive - negative (lower) sideband only

POSitive - positive (upper) sideband only

OFFSet[n] n=1 is the base station test and n=2 is the mobile test. The default is the base station test (1). (cdma2000, W-CDMA mode only)

LIST[m] m=1 is the spectrum emission mask (SEM) mode and m=2 is the adjacent channel power (ACP) mode. The default is the SEM mode (1). (1xEV-DO mode only)

Factory Preset:

Mode	Variant	Offset A	Offset B	Offset C	Offset D	Offset E
cdma2000		BOTH	BOTH	BOTH	BOTH	BOTH
W-CDMA		BOTH	BOTH	BOTH	BOTH	BOTH
1xEV-DO	SEM	BOTH	BOTH	BOTH	BOTH	BOTH
	ACP	BOTH	BOTH	BOTH	BOTH	BOTH

Remarks: You must be in the cdma2000, W-CDMA, or 1xEV-DO mode to use this command. Use INSTRument:SElect to set the mode.

Spectrum Emission Mask—Offset Start Absolute Power Limit

cdma2000, W-CDMA mode

```
[ :SENSe] :SEMAsk:OFFSet [n] :LIST:StARt:ABSolute
<abs_power>, <abs_power>, <abs_power>, <abs_power>, <abs_power>
```

```
[ :SENSe] :SEMAsk:OFFSet [n] :LIST:StARt:ABSolute?
```

1xEV-DO mode

```
[ :SENSe] :SEMAsk:OFFSet:LIST [m] :StARt:ABSolute
<abs_power>, <abs_power>, <abs_power>, <abs_power>, <abs_power>
```

```
[ :SENSe] :SEMAsk:OFFSet:LIST [M] :StARt:ABSolute?
```

Sets an absolute power level for each offset start limit. The list must

contain five (5) entries. If there is more than one offset, the offset closest to the carrier channel comes first in the list.

The fail condition for each offset channel is set by
[:SENS]:SEM:OFFS[n]:LIST[m]:TEST.

You can turn off (not use) specific offset channels with
[:SENS]:SEM:OFFS[n]:LIST[m]:STAT.

The query returns the five (5) sets of the real values currently set to the absolute power test limits.

OFFSet[n] n=1 is the base station test and n=2 is the mobile test.
The default is the base station test (1). (cdma2000,
W-CDMA mode only)

LIST[m] m=1 is the spectrum emission mask (SEM) mode and
m=2 is the adjacent channel power (ACP) mode. The
default is the SEM mode (1). (1xEV-DO mode only)

Factory Preset:

Mode	Variant	Offset A	Offset B	Offset C	Offset D	Offset E
cdma2000	BTS	-27.0 dBm	-27.0 dBm	-27.0 dBm	-46.00 dBm	-13.00 dBm
	MS	-70.13 dBm	-70.13 dBm	-35.00 dBm	-13.00 dBm	-13.00 dBm
W-CDMA	BTS	-12.50 dBm	-12.50 dBm	-24.50 dBm	-11.50 dBm	-11.50 dBm
	MS	-69.57 dBm	-54.34 dBm	-54.34 dBm	-54.34 dBm	-54.34 dBm
1xEV-DO	SEM	-27.00 dBm	-27.00 dBm	-27.00 dBm	-46.00 dBm	-13.00 dBm
	ACP	-27.00 dBm	-27.00 dBm	-13.00 dBm	-13.00 dBm	-13.00 dBm

Range: -200.0 dBm to 50.0 dBm

Default Unit: dBm

Remarks: You must be in the cdma2000, W-CDMA, or 1xEV-DO
mode to use this command. Use INSTRument:SElect to
set the mode.

Spectrum Emission Mask—Offset Start Relative Power Limit

cdma2000, W-CDMA mode

```
[:SENSe]:SEMAsk:OFFSet [n]:LIST:START:RCARrier
<rel_power>,<rel_power>,<rel_power>,<rel_power>,<rel_power>
```

```
[:SENSe]:SEMAsk:OFFSet [n]:LIST:START:RCARrier?
```

1xEV-DO mode

```
[:SENSe]:SEMAsk:OFFSet:LIST [m]:START:RCARrier
```

<rel_power>, <rel_power>, <rel_power>, <rel_power>, <rel_power>

[[:SENSe]:SEMAsk:OFFSet:LIST[m]:STARt:RCARrier?

Set a relative power level for each offset start limit. The list must contain five (5) entries. If there is more than one offset, the offset closest to the carrier channel comes first in the list.

The fail condition is set by [[:SENS]:SEM:OFFS[n]:LIST[m]:TEST for each offset channel test.

You can turn off (not use) specific offset channels with [[:SENS]:SEM:OFFS[n]:LIST[m]:STAT.

The query returns the five (5) sets of the real values currently set to the relative power test limits.

OFFSet[n] n=1 is the base station test and n=2 is the mobile test. The default is the base station test (1). (cdma2000, W-CDMA mode only)

LIST[m] m=1 is the spectrum emission mask (SEM) mode and m=2 is the adjacent channel power (ACP) mode. The default is the SEM mode (1). (1xEV-DO mode only)

Factory Preset:

Mode	Variant	Offset A	Offset B	Offset C	Offset D	Offset E
cdma2000	BTS	-45.00 dB	-45.00 dB	-55.00 dB	-55.00 dB	-55.00 dB
	MS	-42.00 dB	-54.00 dB	-54.00 dB	-54.00 dB	-54.00 dB
W-CDMA	BTS	-30.00 dB	-30.00 dB	-30.00 dB	-30.00 dB	-30.00 dB
	MS	-33.73 dB	-34.00 dB	-37.50 dB	-47.50 dB	-47.50 dB
1xEV-DO	SEM	-45.00 dB	-45.00 dB	-55.00 dB	-55.00 dB	-55.00 dB
	ACP	-45.00 dB	-55.00 dB	-55.00 dB	-55.00 dB	-55.00 dB

Range: -150.0 dBm to 50.0 dB

Default Unit: dB

Remarks: You must be in the cdma2000, W-CDMA, or 1xEV-DO mode to use this command. Use INSTRument:SElect to set the mode.

Spectrum Emission Mask—Offset Measurement State

cdma2000, W-CDMA mode

[[:SENSe]:SEMAsk:OFFSet [n]:LIST:STATE

OFF|ON|0|1, OFF|ON|0|1, OFF|ON|0|1, OFF|ON|0|1, OFF|ON|0|1

`[:SENSe] :SEMAsk:OFFSet [n] :LIST:STATe?`

1xEV-DO mode

`[:SENSe] :SEMAsk:OFFSet:LIST [m] :STATe`
`OFF | ON | 0 | 1, OFF | ON | 0 | 1, OFF | ON | 0 | 1, OFF | ON | 0 | 1, OFF | ON | 0 | 1`

`[:SENSe] :SEMAsk:OFFSet:LIST [m] :STATe?`

Define whether or not to execute pass/fail tests at the offset channels. The pass/fail conditions are set by `[:SENS] :SEM:OFFS[n]:LIST[m]:ABS` or `[:SENS] :SEM:OFFS[n]:LIST[m]:RCAR` for each offset channel.

OFFSet[n] `n=1` is the base station test and `n=2` is the mobile test. The default is the base station test (1). (cdma2000, W-CDMA mode only)

LIST[m] `m=1` is the spectrum emission mask (SEM) mode and `m=2` is the adjacent channel power (ACP) mode. The default is the SEM mode (1). (1xEV-DO mode only)

Factory Preset:

Mode	Variant	Offset A	Offset B	Offset C	Offset D	Offset E
cdma2000	BTS	ON	ON	ON	OFF	OFF
	MS	ON	ON	OFF	OFF	OFF
W-CDMA	BTS	ON	ON	ON	ON	ON
	MS	ON	ON	ON	ON	OFF
1xEV-DO	SEM	ON	ON	ON	OFF	OFF
	ACP	ON	ON	OFF	OFF	OFF

Remarks: You must be in the cdma2000, W-CDMA, or 1xEV-DO mode to use this command. Use `INSTRument:SElect` to set the mode.

Spectrum Emission Mask—Offset Stop Absolute Power Limit

cdma2000, W-CDMA mode

`[:SENSe] :SEMAsk:OFFSet [n] :LIST:STOP:ABSolute`
`<abs_power>, <abs_power>, <abs_power>, <abs_power>, <abs_power>`

`[:SENSe] :SEMAsk:OFFSet [n] :LIST:STOP:ABSolute?`

1xEV-DO. mode

`[:SENSe] :SEMAsk:OFFSet:LIST [m] :STOP:ABSolute`
`<abs_power>, <abs_power>, <abs_power>, <abs_power>, <abs_power>`

`[:SENSe] :SEMAsk:OFFSet:LIST [m] :STOP:ABSolute?`

Set an absolute power level to for each offset stop limit. The list must contain five (5) entries. If there is more than one offset, the offset closest to the carrier channel comes first in the list.

The fail condition is set by [:SENS]:SEM:OFFS[n]:LIST[m]:TEST for each offset channel test.

You can turn off (not use) specific offset channels with [:SENS]:SEM:OFFS[n]:LIST[m]:STAT.

The query returns the five (5) sets of the real values currently set to the offset stop absolute power limits.

OFFSet[n] n=1 is the base station test and n=2 is the mobile test. The default is the base station test (1). (cdma2000, W-CDMA mode only)

LIST[m] m=1 is the spectrum emission mask (SEM) mode and m=2 is the adjacent channel power (ACP) mode. The default is the SEM mode (1). (1xEV-DO mode only)

Factory Preset:

Mode	Variant	Offset A	Offset B	Offset C	Offset D	Offset E
cdma2000	BTS	-27.00 dBm	-27.00 dBm	-27.00 dBm	-46.00 dBm	-13.00 dBm
	MS	-70.13 dBm	-70.13 dBm	-35.00 dBm	-13.00 dBm	-13.00 dBm
W-CDMA	BTS	-12.50 dBm	-24.50 dBm	-24.50 dBm	-11.50 dBm	-11.50 dBm
	MS	-69.57 dBm	-54.34 dBm	-54.34 dBm	-54.34 dBm	-54.34 dBm
1xEV-DO	SEM	-27.00 dBm	-27.00 dBm	-27.00 dBm	-46.00 dBm	-13.00 dBm
	ACP	-27.00 dBm	-27.00 dBm	-13.00 dBm	-13.00 dBm	-13.00 dBm

Range: -200.0 dBm to 50.0 dBm

Default Unit: dBm

Remarks: You must be in the cdma2000, W-CDMA, or 1xEV-DO mode to use this command. Use INSTRument:SElect to set the mode.

Spectrum Emission Mask—Couple Offset Stop Absolute Power Limit

cdma2000, W-CDMA mode

```
[:SENSe]:SEMAsk:OFFSet [n]:LIST:STOP:ABSolute:COUPLE  
OFF|ON|0|1,OFF|ON|0|1,OFF|ON|0|1,OFF|ON|0|1,OFF|ON|0|1
```

```
[:SENSe]:SEMAsk:OFFSet [n]:LIST:STOP:ABSolute:COUPLE?
```

1xEV-DO mode

```
[ :SENSe] :SEMAsk:OFFSet:LIST [m] :STOP:ABSolute:COUPle  
OFF | ON | 0 | 1, OFF | ON | 0 | 1, OFF | ON | 0 | 1, OFF | ON | 0 | 1, OFF | ON | 0 | 1
```

```
[ :SENSe] :SEMAsk:OFFSet:LIST [m] :STOP:ABSolute:COUPle?
```

Define whether or not to couple the offset stop absolute power limit to the offset start absolute power limit for each offset channel.

You can turn off (not use) specific offset channels with
[:SENS]:SEM:OFFS[n]:LIST[m]:STAT.

OFFSet[n] n=1 is the base station test and n=2 is the mobile test.
The default is the base station test (1). (cdma2000,
W-CDMA mode only)

LIST[m] m=1 is the spectrum emission mask (SEM) mode and
m=2 is the adjacent channel power (ACP) mode. The
default is the SEM mode (1). (1xEV-DO mode only)

Factory Preset:

Mode	Variant	Offset A	Offset B	Offset C	Offset D	Offset E
cdma2000	BTS	ON	ON	ON	ON	ON
	MS	ON	ON	ON	ON	ON
W-CDMA	BTS	ON	OFF	ON	ON	ON
	MS	ON	ON	ON	ON	ON
1xEV-DO	SEM	ON	ON	ON	ON	ON
	ACP	ON	ON	ON	ON	ON

Remarks: You must be in the cdma2000, W-CDMA, or 1xEV-DO
mode to use this command. Use INSTRument:SElect to
set the mode.

Spectrum Emission Mask—Offset Stop Relative Power Limit

cdma2000, W-CDMA mode

```
[ :SENSe] :SEMAsk:OFFSet [n] :LIST:STOP:RCARrier  
<rel_power>, <rel_power>, <rel_power>, <rel_power>, <rel_power>
```

```
[ :SENSe] :SEMAsk:OFFSet [n] :LIST:STOP:RCARrier?
```

1xEV-DO mode

```
[ :SENSe] :SEMAsk:OFFSet:LIST [m] :STOP:RCARrier  
<rel_power>, <rel_power>, <rel_power>, <rel_power>, <rel_power>
```

```
[ :SENSe] :SEMAsk:OFFSet:LIST [m] :STOP:RCARrier?
```

Set a relative power level for each offset stop limit. The list must contain five (5) entries. If there is more than one offset, the offset closest to the carrier channel comes first in the list.

The fail condition is set by [:SENS]:SEM:OFFS[n]:LIST[m]:TEST for each offset channel.

You can turn off (not use) specific offset channels with [:SENS]:SEM:OFFS[n]:LIST[m]:STAT.

The query returns the five (5) sets of the real values currently set to the offset stop relative power limits.

OFFSet[n] n=1 is the base station test and n=2 is the mobile test. The default is the base station test (1). (cdma2000, W-CDMA mode only)

LIST[m] m=1 is the spectrum emission mask (SEM) mode and m=2 is the adjacent channel power (ACP) mode. The default is the SEM mode (1). (1xEV-DO mode only)

Factory Preset:

Mode	Variant	Offset A	Offset B	Offset C	Offset D	Offset E
cdma2000	BTS	-45.00 dB	-45.00 dB	-55.00 dB	-55.00 dB	-55.00 dB
	MS	-42.00 dB	-54.00 dB	-54.00 dB	-54.00 dB	-54.00 dB
W-CDMA	BTS	-30.00 dB	-30.00 dB	-30.00 dB	-30.00 dB	-30.00 dB
	MS	-48.28 dB	-37.50 dB	-47.50 dB	-47.50 dB	-47.50 dB
1xEV-DO	SEM	-45.00 dB	-45.00 dB	-55.00 dB	-55.00 dB	-55.00 dB
	ACP	-45.00 dB	-55.00 dB	-55.00 dB	-55.00 dB	-55.00 dB

Range: -150.0 dBm to 50.0 dB

Default Unit: dB

Remarks: You must be in the cdma2000, W-CDMA, or 1xEV-DO mode to use this command. Use INSTRument:SElect to set the mode.

Spectrum Emission Mask—Couple Offset Stop Relative Power Limit

cdma2000, W-CDMA mode

```
[:SENSe]:SEMAsk:OFFSet [n]:LIST:STOP:RCARrier:COUPLE
OFF|ON|0|1,OFF|ON|0|1,OFF|ON|0|1,OFF|ON|0|1,OFF|ON|0|1
```

```
[:SENSe]:SEMAsk:OFFSet [n]:LIST:STOP:RCARrier:COUPLE?
```

1xEV-DO mode

```
[ :SENSe ] :SEMAsk:OFFSet:LIST [m] :STOP:RCARrier:COUPle  
OFF | ON | 0 | 1, OFF | ON | 0 | 1, OFF | ON | 0 | 1, OFF | ON | 0 | 1, OFF | ON | 0 | 1
```

```
[ :SENSe ] :SEMAsk:OFFSet:LIST [m] :STOP:RCARrier:COUPle?
```

Define whether or not to couple the offset stop relative power limit to the offset start relative power limit for each offset channel.

You can turn off (not use) specific offset channels with
[:SENS]:SEM:OFFS[n]:LIST[m]:STAT.

OFFSet[n] n=1 is the base station test and n=2 is the mobile test.
The default is the base station test (1). (cdma2000,
W-CDMA mode only)

LIST[m] m=1 is the spectrum emission mask (SEM) mode and
m=2 is the adjacent channel power (ACP) mode. The
default is the SEM mode (1). (1xEV-DO mode only)

Factory Preset:

Mode	Variant	Offset A	Offset B	Offset C	Offset D	Offset E
cdma2000	BTS	ON	ON	ON	ON	ON
	MS	ON	ON	ON	ON	ON
W-CDMA	BTS	ON	ON	ON	ON	ON
	MS	OFF	OFF	OFF	ON	ON
1xEV-DO	SEM	ON	ON	ON	ON	ON
	ACP	ON	ON	ON	ON	ON

Remarks: You must be in the cdma2000, W-CDMA, or 1xEV-DO
mode to use this command. Use INSTRument:SElect to
set the mode.

Spectrum Emission Mask—Offset Channel Fail Condition

cdma2000, W-CDMA mode

```
[ :SENSe ] :SEMAsk:OFFSet [n] :LIST:TEST  
ABSolute | AND | OR | RELative, ABSolute | AND | OR | RELative,  
ABSolute | AND | OR | RELative, ABSolute | AND | OR | RELative,  
ABSolute | AND | OR | RELative
```

```
[ :SENSe ] :SEMAsk:OFFSet [n] :LIST:TEST?
```

1xEV-DO mode

```
[ :SENSe ] :SEMAsk:OFFSet:LIST [m] :TEST
```

ABSolute | AND | OR | RELative, ABSolute | AND | OR | RELative,
ABSolute | AND | OR | RELative, ABSolute | AND | OR | RELative,
ABSolute | AND | OR | RELative

[:SENSe] :SEMAsk:OFFSet:LIST [m] :TEST?

Define one of the fail conditions for each offset channel limit test to be done. The absolute or relative power limit value for each offset channel is set by [:SENS]:SEM:OFFS[n]:LIST[m]:ABS or [:SENS]:SEM:OFFS[n]:LIST[m]:RCAR.

You can turn off (not use) specific offset channels with [:SENS]:SEM:OFFS[n]:LIST[m]:STAT.

OFFSet[n] n=1 is the base station test and n=2 is the mobile test. The default is the base station test (1). (cdma2000, W-CDMA mode only)

LIST[m] m=1 is the spectrum emission mask (SEM) mode and m=2 is the adjacent channel power (ACP) mode. The default is the SEM mode (1). (1xEV-DO mode only)

The fail condition that can be set for each offset channel include:

- AND - Tests the measurement result for an offset channel against both the absolute power limit and the relative power limit. If it fails, then returns a failure for that measurement test.
- ABSolute - Tests the measurement result for an offset channel against the absolute power limit. If it fails, then returns a failure for that measurement test.
- OR - Tests the measurement result for an offset channel against the absolute power limit OR the relative power limit. If either test fails, then returns a failure for that measurement test.
- RELative - Tests the measurement result for an offset channel against the relative power limit. If it fails, then returns a failure for that measurement test.

Factory Preset:

Mode	Variant	Offset A	Offset B	Offset C	Offset D	Offset E
cdma2000	BTS	REL	REL	REL	ABS	REL
	MS	AND	AND	ABS	REL	REL
W-CDMA	BTS	ABS	ABS	ABS	ABS	ABS
	MS	AND	AND	AND	AND	AND
1xEV-DO	SEM	REL	REL	REL	ABS	REL
	ACP	REL	REL	ABS	REL	REL

Remarks: You must be in the cdma2000, W-CDMA, or 1xEV-DO mode to use this command. Use INSTRument:SElect to set the mode.

Spectrum Emission Mask—Region Resolution Bandwidth

cdma2000, W-CDMA mode

```
[ :SENSe ] :SEMAsk:REGion [n] :LIST:BAWdwidth | BWIDth  
<res_bw>, <res_bw>, <res_bw>, <res_bw>, <res_bw>
```

```
[ :SENSe ] :SEMAsk:REGion [n] :LIST:BAWdwidth | BWIDth?
```

1xEV-DO mode

```
[ :SENSe ] :SEMAsk:REGion:LIST:BAWdwidth | BWIDth  
<res_bw>, <res_bw>, <res_bw>, <res_bw>, <res_bw>
```

```
[ :SENSe ] :SEMAsk:REGion:LIST:BAWdwidth | BWIDth?
```

Define the region resolution bandwidth(s) for spectrum emission measurements. The list must contain five (5) entries. You can turn off (not use) specific regions with [:SENS]:SEM:REG[n]:LIST:STAT.

REGion[n] n=1 is the base station test and n=2 is the mobile test. The default is the base station test (1). (cdma2000, W-CDMA mode only)

Factory Preset and *RST: Auto coupled, except cdma2000, see below.

Mode	Variant	Region A	Region B	Region C	Region D	Region E
cdma2000	BTS	1.000 MHz	300.0 kHz	100.0 kHz	100.0 kHz	4.000 MHz
	MS	300.0 kHz	100.0 kHz	100.0 kHz	100.0 kHz	12.00 MHz

Range: 300 Hz to 7.5 MHz

Default Unit: Hz

Remarks: You must be in the cdma2000, W-CDMA, or 1xEV-DO mode to use this command. Use INSTRument:SElect to set the mode.

Spectrum Emission Mask—Auto Region Resolution Bandwidth

cdma2000, W-CDMA mode

```
[ :SENSe ] :SEMAsk:REGion [n] :LIST:BAWdwidth | BWIDth:AUTO  
OFF | ON | 0 | 1, OFF | ON | 0 | 1, OFF | ON | 0 | 1, OFF | ON | 0 | 1, OFF | ON | 0 | 1
```

`[:SENSE] :SEMask:REGion [n] :LIST:BANDwidth | BWIDth:AUTO?`

1xEV-DO mode

`[:SENSE] :SEMask:REGion:LIST:BANDwidth | BWIDth:AUTO
OFF | ON | 0 | 1, OFF | ON | 0 | 1, OFF | ON | 0 | 1, OFF | ON | 0 | 1, OFF | ON | 0 | 1`

`[:SENSE] :SEMask:REGion:LIST:BANDwidth | BWIDth:AUTO?`

Set the auto mode of the region step frequency.

Set the auto mode to determine the region resolution bandwidth to On or Off.

OFF - enter a value to set the resolution bandwidth for a region channel, referring to `[:SENS] :SEM:REG[n] :LIST:BAND | BWID`.

ON - the resolution bandwidth for a region channel is automatically set according to the region start and stop frequencies.

REGion[n] n=1 is the base station test and n=2 is the mobile test.
The default is the base station test (1). (cdma2000, W-CDMA mode only)

Factory Preset and *RST:

Mode	Region A	Region B	Region C	Region D	Region E
cdma2000	OFF	OFF	OFF	OFF	OFF
W-CDMA	ON	ON	ON	ON	ON
1xEV-DO	ON	ON	ON	ON	ON

Remarks: You must be in the cdma2000, W-CDMA, or 1xEV-DO mode to use this command. Use INSTRument:SElect to set the mode.

Spectrum Emission Mask—Region Start Frequency

cdma2000, W-CDMA mode

`[:SENSE] :SEMask:REGion [n] :LIST:FREQuency:START
<f_region>, <f_region>, <f_region>, <f_region>, <f_region>`

`[:SENSE] :SEMask:REGion [n] :LIST:FREQuency:START?`

1xEV-DO mode

`[:SENSE] :SEMask:REGion:LIST:FREQuency:START
<f_region>, <f_region>, <f_region>, <f_region>, <f_region>`

`[:SENSE] :SEMask:REGion:LIST:FREQuency:START?`

Set the five (5) sets of the region start frequencies.

REGion[n] n=1 is the base station test and n=2 is the mobile test.
The default is the base station test (1). (cdma2000,
W-CDMA mode only)

Factory Preset and *RST:

Mode	Variant	Region A	Region B	Region C	Region D	Region E
cdma2000	BTS	1920.5 MHz	1893.65 MHz	876.05 MHz	921.05 MHz	800.0 MHz
	MS	1920.5 MHz	925.05 MHz	935.05 MHz	1805.05 MHz	800.0 MHz
W-CDMA	n/a	1920.0 MHz	1893.5 MHz	2100.0 MHz	2175.0 MHz	800.0 MHz
1xEV-DO	n/a	1920.0 MHz	1893.5 MHz	2100.0 MHz	2175.0 MHz	800.0 MHz

Range: 329.0 MHz to 3.678 GHz

Default Unit: Hz

Remarks: You must be in the cdma2000, W-CDMA, or 1xEV-DO mode to use this command. Use INSTRument:SElect to set the mode.

Spectrum Emission Mask—Region Step Frequency

cdma2000, W-CDMA mode

[[:SENSe]] :SEMAsk:REGion [n] :LIST:FREQuency:STEP
<f_region>, <f_region>, <f_region>, <f_region>, <f_region>

[[:SENSe]] :SEMAsk:REGion [n] :LIST:FREQuency:STEP?

1xEV-DO mode

[[:SENSe]] :SEMAsk:REGion:LIST:FREQuency:STEP
<f_region>, <f_region>, <f_region>, <f_region>, <f_region>

[[:SENSe]] :SEMAsk:REGion:LIST:FREQuency:STEP?

Sets the five (5) sets of the region step frequencies.

REGion[n] n=1 is the base station test and n=2 is the mobile test.
The default is the base station test (1). (cdma2000,
W-CDMA mode only)

Factory Preset: No valid value as the default is set to Auto. See
[[:SENS]]:SEM:REG[n]:LIST:FREQ:STEP:AUTO.

Range: 100 Hz to 7.5 MHz

The minimum value is determined to be equal to or greater than one 2000th (1/2000) of the frequency difference derived from (Stop Freq – Start Freq).

Default Unit: Hz

Remarks: You must be in the cdma2000, W-CDMA, or 1xEV-DO mode to use this command. Use INSTRUMENT:SElect to set the mode.

Spectrum Emission Mask—Auto Region Step Frequency

cdma2000, W-CDMA mode

```
[ :SENSE ] :SEMask:REGion [n] :LIST:FREQuency:STEP:AUTO  
OFF | ON | 0 | 1, OFF | ON | 0 | 1, OFF | ON | 0 | 1, OFF | ON | 0 | 1, OFF | ON | 0 | 1
```

```
[ :SENSe ] :SEMask:REGion [n] :LIST:FREQuency:STEP:AUTO?
```

1xEV-DO mode

```
[ :SENSE ] :SEMask:REGion:LIST:FREQuency:STEP:AUTO  
OFF | ON | 0 | 1, OFF | ON | 0 | 1, OFF | ON | 0 | 1, OFF | ON | 0 | 1, OFF | ON | 0 | 1
```

```
[ :SENSe ] :SEMask:REGion:LIST:FREQuency:STEP:AUTO?
```

Set the auto mode to determine the region step frequency to On or Off.

OFF - enter a value to set the step frequency for a region channel, referring to [:SENS]:SEM:REG[n]:LIST:FREQ:STEP.

ON - the step frequency for a region channel is automatically set according to the region start and stop frequencies.

REGion[n] n=1 is the base station test and n=2 is the mobile test. The default is the base station test (1). (cdma2000, W-CDMA mode only)

Factory Preset:

Mode	Region A	Region B	Region C	Region D	Region E
cdma2000	ON	ON	ON	ON	ON
W-CDMA	ON	ON	ON	ON	ON
1xEV-DO	ON	ON	ON	ON	ON

Remarks: You must be in the cdma2000, W-CDMA, or 1xEV-DO mode to use this command. Use INSTRUMENT:SElect to set the mode.

Spectrum Emission Mask—Region Stop Frequency

cdma2000, W-CDMA mode

```
[ :SENSe ] :SEMask:REGion [n] :LIST:FREQuency:STOP
```

<f_region>, <f_region>, <f_region>, <f_region>, <f_region>

[:SENSe] :SEMask:REGion [n] :LIST:FREQuency:STOP?

1xEV-DO mode

[:SENSe] :SEMask:REGion:LIST:FREQuency:STOP

<f_region>, <f_region>, <f_region>, <f_region>, <f_region>

[:SENSe] :SEMask:REGion:LIST:FREQuency:STOP?

Sets the five (5) sets of the region stop frequencies.

REGion[n] n=1 is the base station test and n=2 is the mobile test.
The default is the base station test (1). (cdma2000,
W-CDMA mode only)

Factory Preset and *RST:

Mode	Variant	Region A	Region B	Region C	Region D	Region E
cdma2000	BTS	1980.5 MHz	1919.75 MHz	915.05 MHz	960.05 MHz	1000.0 MHz
	MS	1980.5 MHz	935.05 MHz	960.05 MHz	1880.05 MHz	1000.0 MHz
W-CDMA	n/a	1980.0 MHz	1919.6 MHz	2105.0 MHz	2180.0 MHz	1000.0 MHz
1xEV-DO	n/a	1980.0 MHz	1919.6 MHz	2105.0 MHz	2180.0 MHz	1000.0 MHz

Range: 329.0 MHz to 3.678 MHz

Default Unit: Hz

Remarks: You must be in the cdma2000, W-CDMA, or 1xEV-DO mode to use this command. Use INSTRument:SElect to set the mode.

Spectrum Emission Mask—Region Relative Attenuation

cdma2000, W-CDMA mode

[:SENSe] :SEMask:REGion [n] :LIST:RATTenuation

<rel_power>, <rel_power>, <rel_power>, <rel_power>, <rel_power>

[:SENSe] :SEMask:REGion [n] :LIST:RATTenuation?

1xEV-DO mode

[:SENSe] :SEMask:REGion:LIST:RATTenuation

<rel_power>, <rel_power>, <rel_power>, <rel_power>, <rel_power>

[:SENSe] :SEMask:REGion:LIST:RATTenuation?

Set a relative amount of attenuation for measurements made at a region. The amount is specified relative to the attenuation required to

measure the carrier channel power. Since the region channel power is lower than the carrier channel power, less attenuation is required to measure the region channel and you get wider dynamic range for the measurement.

You can turn off (not use) specific regions with
[:SENS]:SEM:REG[n]:LIST:STAT.

REGion[n] n=1 is the base station test and n=2 is the mobile test.
The default is the base station test (1). (cdma2000,
W-CDMA mode only)

Factory Preset:

Mode	Variant	Region A	Region B	Region C	Region D	Region E
cdma2000	BTS	0.00 dB	0.00 dB	0.00 dB	0.00 dB	0.00 dB
	MS	0.00 dB	0.00 dB	0.00 dB	0.00 dB	0.00 dB
W-CDMA	n/a	0.00 dB	0.00 dB	0.00 dB	0.00 dB	0.00 dB
1xEV-DO	n/a	0.00 dB	0.00 dB	0.00 dB	0.00 dB	0.00 dB

Range: -40.00 to 0.00 dB, but this relative attenuation cannot exceed the absolute attenuation ranging from 0.00 to 40.00 dB.

Remarks: Remember that the attenuation that you specify is always relative to the amount of attenuation used for the carrier channel. Selecting negative attenuation means that you want less attenuation used. For example, if the measurement must use 20 dB of attenuation for the carrier measurement and you want to use 12 dB less attenuation for the first region, you would send the value -12 dB.

You must be in the cdma2000, W-CDMA, or 1xEV-DO mode to use this command. Use INSTRument:SElect to set the mode.

Spectrum Emission Mask—Region Start Absolute Power Limit

cdma2000, W-CDMA (3GPP) mode

```
[:SENSe]:SEMAsk:REGion[n]:LIST:START:ABSolute
<abs_power>,<abs_power>,<abs_power>,<abs_power>,<abs_power>
```

```
[:SENSe]:SEMAsk:REGion[n]:LIST:START:ABSolute?
```

1xEV-DO mode

```
[:SENSe]:SEMAsk:REGion:LIST:START:ABSolute
<abs_power>,<abs_power>,<abs_power>,<abs_power>,<abs_power>
```

[[:SENSe]:SEMAsk:REGion:LIST:START:ABSolute?

Set an absolute power level for each region start limit. The list must contain five (5) entries. If there is more than one region, the region closest to the carrier channel comes first in the list.

The fail condition for each region channel is set by
[:SENS]:SEM:REG[n]:LIST:TEST.

You can turn off (not use) specific regions with
[:SENS]:SEM:REG[n]:LIST:STAT.

The query returns the five (5) sets of the real values currently set to the absolute power test limits.

REGion[n] n=1 is the base station test and n=2 is the mobile test.
The default is the base station test (1). (cdma2000,
W-CDMA mode only)

Factory Preset:

Mode	Variant	Region A	Region B	Region C	Region D	Region E
cdma2000	BTS	-86.00 dBm	-41.00 dBm	-98.00 dBm	-57.00 dBm	-50.00 dBm
	MS	-41.00 dBm	-67.00 dBm	-79.00 dBm	-71.00 dBm	-50.00 dBm
W-CDMA		-50.00 dBm	-50.00 dBm	-50.00 dBm	-50.00 dBm	-50.00 dBm
1xEV-DO		-50.00 dBm	-50.00 dBm	-50.00 dBm	-50.00 dBm	-50.00 dBm

Range: -200.00 dBm to 50.00 dBm

Default Unit: dBm

Remarks: You must be in the cdma2000, W-CDMA, or 1xEV-DO mode to use this command. Use INSTRument:SElect to set the mode.

Spectrum Emission Mask—Region Start Relative Power Limit

cdma2000, W-CDMA mode

[[:SENSe]:SEMAsk:REGion[n]:LIST:START:RCARrier
<rel_power>,<rel_power>,<rel_power>,<rel_power>,<rel_power>

[[:SENSe]:SEMAsk:REGion[n]:LIST:START:RCARrier?

1xEV-DO mode

[[:SENSe]:SEMAsk:REGion:LIST:START:RCARrier
<rel_power>,<rel_power>,<rel_power>,<rel_power>,<rel_power>

[[:SENSe]:SEMAsk:REGion:LIST:START:RCARrier?

Set a relative power level for each region start limit. The list must

contain five (5) entries. If there is more than one region, the region closest to the carrier channel comes first in the list.

The fail condition is set by [:SENS]:SEM:REG[n]:LIST:TEST for each region test.

You can turn off (not use) specific regions with [:SENS]:SEM:REG[n]:LIST:STAT.

The query returns the five (5) sets of the real values currently set to the relative power test limits.

REGion[n] n=1 is the base station test and n=2 is the mobile test.
The default is the base station test (1). (cdma2000, W-CDMA mode only)

Factory Preset:

Mode	Region A	Region B	Region C	Region D	Region E
cdma2000	-30.00 dB	-30.00 dB	-30.00 dB	-30.00 dB	-30.00 dB
W-CDMA	-30.00 dB	-30.00 dB	-30.00 dB	-30.00 dB	-30.00 dB
1xEV-DO	-30.00 dB	-30.00 dB	-30.00 dB	-30.00 dB	-30.00 dB

Range: -150.00 dBm to 50.00 dB

Default Unit: dB

Remarks: You must be in the cdma2000, W-CDMA, or 1xEV-DO mode to use this command. Use INSTRument:SElect to set the mode.

Spectrum Emission Mask—Control Region List State

cdma2000, W-CDMA mode

```
[:SENSe]:SEMAsk:REGion [n]:LIST:STATe
OFF|ON|0|1,OFF|ON|0|1,OFF|ON|0|1,OFF|ON|0|1,OFF|ON|0|1
```

```
[:SENSe]:SEMAsk:REGion [n]:LIST:STATe?
```

1xEV-DO mode

```
[:SENSe]:SEMAsk:REGion:LIST:STATe
OFF|ON|0|1,OFF|ON|0|1,OFF|ON|0|1,OFF|ON|0|1,OFF|ON|0|1
```

```
[:SENSe]:SEMAsk:REGion:LIST:STATe?
```

Define whether or not to execute pass/fail tests at custom region frequencies. The pass/fail conditions are set by [:SENS]:SEM:REG[n]:LIST:ABS or [:SENS]:SEM:REG[n]:LIST:RCAR for each region.

REGion[n] n=1 is the base station test and n=2 is the mobile test. The default is the base station test (1). (cdma2000, W-CDMA mode only)

Factory Preset and *RST:

Mode	Region A	Region B	Region C	Region D	Region E
cdma2000	ON	ON	OFF	OFF	OFF
W-CDMA	ON	ON	ON	OFF	OFF
1xEV-DO	ON	ON	ON	OFF	OFF

Remarks: You must be in the cdma2000, W-CDMA, or 1xEV-DO mode to use this command. Use INSTRument:SElect to set the mode.

Spectrum Emission Mask—Region Stop Absolute Power Limit

cdma2000, W-CDMA mode

```
[ :SENSe ] :SEMask:REGion [n] :LIST:STOP:ABSolute
<abs_power>, <abs_power>, <abs_power>, <abs_power>, <abs_power>
```

```
[ :SENSe ] :SEMask:REGion [n] :LIST:STOP:ABSolute?
```

1xEV-DO mode

```
[ :SENSe ] :SEMask:REGion:LIST:STOP:ABSolute
<abs_power>, <abs_power>, <abs_power>, <abs_power>, <abs_power>
```

```
[ :SENSe ] :SEMask:REGion:LIST:STOP:ABSolute?
```

Set an absolute power level for each region stop limit. The list must contain five (5) entries. If there is more than one region, the region closest to the carrier channel comes first in the list.

The fail condition is set by [:SENS]:SEM:REG[n]:LIST:TEST for each region test.

You can turn off (not use) specific regions with [:SENS]:SEM:REG[n]:LIST:STAT.

The query returns the five (5) sets of the real values currently set to the region stop absolute power limits.

REGion[n] n=1 is the base station test and n=2 is the mobile test. The default is the base station test (1). (cdma2000, W-CDMA mode only)

Factory Preset and *RST:

Mode	Variant	Region A	Region B	Region C	Region D	Region E
cdma2000	BTS	-86.00 dBm	-41.00 dBm	-98.00 dBm	-57.00 dBm	-50.00 dBm
	MS	-41.00 dBm	-67.00 dBm	-79.00 dBm	-71.00 dBm	-50.00 dBm
W-CDMA	n/a	-50.00 dBm	-50.00 dBm	-50.00 dBm	-50.00 dBm	-50.00 dBm
1xEV-DO	n/a	-50.00 dBm	-50.00 dBm	-50.00 dBm	-50.00 dBm	-50.00 dBm

Range: -200.00 dBm to 50.00 dBm

Unit: dBm

Remarks: You must be in the cdma2000, W-CDMA, or 1xEV-DO mode to use this command. Use INSTRUMENT:SElect to set the mode.

Spectrum Emission Mask—Couple Region Stop Absolute Power Limit

```
[ :SENSe ] :SEMAsk:REGion [n] :LIST:STOP:ABSolute:COUple  
OFF | ON | 0 | 1 { , OFF | ON | 0 | 1 }
```

```
[ :SENSe ] :SEMAsk:REGion [n] :LIST:STOP:ABSolute:COUple?
```

Define whether or not to couple the region stop absolute power limit to the region start absolute power limit for each region.

You can turn off (not use) specific regions with
[:SENS]:SEM:REG[n]:LIST:STAT.

REGion[n] n=1 is the base station test and n=2 is the mobile test.
The default is the base station test (1). (cdma2000,
W-CDMA mode only)

Factory Preset:

Mode	Region A	Region B	Region C	Region D	Region E
cdma2000	ON	ON	ON	ON	ON
W-CDMA	ON	ON	ON	ON	ON
1xEV-DO	ON	ON	ON	ON	ON

Remarks: You must be in the cdma2000, W-CDMA, or 1xEV-DO mode to use this command. Use INSTRUMENT:SElect to set the mode.

Spectrum Emission Mask—Region Stop Relative Power Limit

cdma2000, W-CDMA mode

```
[ :SENSe ] :SEMAsk:REGion [n] :LIST:STOP:RCARrier  
<rel_power>,<rel_power>,<rel_power>,<rel_power>,<rel_power>
```

```
[ :SENSe ] :SEMAsk:REGion [n] :LIST:STOP:RCARrier?
```

1xEV-DO mode

```
[ :SENSe ] :SEMAsk:REGion:LIST:STOP:RCARrier  
<rel_power>,<rel_power>,<rel_power>,<rel_power>,<rel_power>
```

```
[ :SENSe ] :SEMAsk:REGion:LIST:STOP:RCARrier?
```

Set a relative power level for each region stop limit. The list must contain five (5) entries. If there is more than one region, the region closest to the carrier channel comes first in the list.

The fail condition is set by [:SENS]:SEM:REG[n]:LIST[m]:TEST for each region.

You can turn off (not use) specific regions with [:SENS]:SEM:REG[n]:LIST:STAT.

The query returns the five (5) sets of the real values currently set to the region stop relative power limits.

REGion[n] n=1 is the base station test and n=2 is the mobile test. The default is the base station test (1). (cdma2000, W-CDMA mode only)

Factory Preset:

Mode	Region A	Region B	Region C	Region D	Region E
cdma2000	-30.00 dB	-30.00 dB	-30.00 dB	-30.00 dB	-30.00 dB
W-CDMA	-30.00 dB	-30.00 dB	-30.00 dB	-30.00 dB	-30.00 dB
1xEV-DO	-30.00 dB	-30.00 dB	-30.00 dB	-30.00 dB	-30.00 dB

Range: -150.00 dBm to 50.00 dB

Default Unit: dB

Remarks: You must be in the cdma2000, W-CDMA, or 1xEV-DO mode to use this command. Use INSTRument:SElect to set the mode.

Spectrum Emission Mask—Couple Region Stop Relative Power Limit

cdma2000, W-CDMA mode

```
[ :SENSe] :SEMAsk:REGion [n] :LIST:STOP:RCARrier:COUple
OFF | ON | 0 | 1, OFF | ON | 0 | 1, OFF | ON | 0 | 1, OFF | ON | 0 | 1, OFF | ON | 0 | 1
```

```
[ :SENSe] :SEMAsk:REGion [n] :LIST:STOP:RCARrier:COUple?
```

1xEV-DO mode

```
[ :SENSe] :SEMAsk:REGion:LIST:STOP:RCARrier:COUple
OFF | ON | 0 | 1, OFF | ON | 0 | 1, OFF | ON | 0 | 1, OFF | ON | 0 | 1, OFF | ON | 0 | 1
```

```
[ :SENSe] :SEMAsk:REGion:LIST:STOP:RCARrier:COUple?
```

Define whether or not to couple the region stop relative power limit to the region start relative power limit for each region.

You can turn off (not use) specific regions with
[:SENS]:SEM:REG[n]:LIST:STAT.

REGion[n] n=1 is the base station test and n=2 is the mobile test.
The default is the base station test (1). (cdma2000,
W-CDMA mode only)

Factory Preset:

Mode	Region A	Region B	Region C	Region D	Region E
cdma2000	ON	ON	ON	ON	ON
W-CDMA	ON	ON	ON	ON	ON
1xEV-DO	ON	ON	ON	ON	ON

Remarks: You must be in the cdma2000, W-CDMA, or 1xEV-DO mode to use this command. Use INSTRument:SElect to set the mode.

Spectrum Emission Mask—Region Limit Test Fail Condition

cdma2000, W-CDMA mode

```
[ :SENSe] :SEMAsk:REGion [n] :LIST:TEST
ABSolute | AND | OR | RELative, ABSolute | AND | OR | RELative,
ABSolute | AND | OR | RELative, ABSolute | AND | OR | RELative,
ABSolute | AND | OR | RELative
```

```
[ :SENSe] :SEMAsk:REGion [n] :LIST:TEST?
```

1xEV-DO mode

```
[ :SENSe] :SEMAsk:REGion:LIST:TEST
ABSolute | AND | OR | RELative, ABSolute | AND | OR | RELative,
ABSolute | AND | OR | RELative, ABSolute | AND | OR | RELative,
ABSolute | AND | OR | RELative
```

```
[ :SENSe] :SEMAsk:REGion:LIST:TEST?
```

Define one of the fail conditions for each region limit test to be done. The absolute or relative test limit value for each region is set by [:SENS]:SEM:REG[n]:LIST:ABS or [:SENS]:SEM:REG[n]:LIST:RCAR.

You can turn off (not use) specific regions with [:SENS]:SEM:REG[n]:LIST[m]:STAT.

REGion[n] n=1 is the base station test and n=2 is the mobile test. The default is the base station test (1). (cdma2000, W-CDMA mode only)

The fail condition that can be set for each region test include:

- AND - Tests the measurement result for a region against both the absolute power limit and the relative power limit. If it fails, then returns a failure for that measurement test.
- ABSolute - Tests the measurement result for a region against the absolute power limit. If it fails, then returns a failure for that measurement test.
- OR - Tests the measurement result for a region against the absolute power limit OR the relative power limit. If either test fails, then returns a failure for that measurement test.
- RELative - Tests the measurement result for a region against the relative power limit. If it fails, then returns a failure for that measurement test.

Factory Preset:

Mode	Region A	Region B	Region C	Region D	Region E
cdma2000	ABS	ABS	ABS	ABS	ABS
W-CDMA	ABS	ABS	ABS	ABS	ABS
1xEV-DO	ABS	ABS	ABS	ABS	ABS

Remarks: You must be in the cdma2000, W-CDMA, or 1xEV-DO mode to use this command. Use INSTRument:SElect to set the mode.

Spectrum Emission Mask—Spectrum Segment

[:SENSe]:SEMAsk:SEGment OFFSet|REGion

[:SENSe]:SEMAsk:SEGment?

Set the frequency spectrum measurement segment to either the offset channels with relative frequencies or the regions with absolute frequencies.

Factory Preset: OFFset

Remarks: You must be in the cdma2000, W-CDMA, or 1xEV-DO mode to use this command. Use INSTRUMENT:SElect to set the mode.

Spectrum Emission Mask—Measurement Mode

`[:SENSE] :SEMAsk :SEGMENT :TYPE ACPr | SEMAsk`

`[:SENSe] :SEMAsk :SEGMENT :TYPE?`

Set the measurement mode to either the SEM (spectrum emission mask) mode or the ACP (adjacent channel power) mode.

Factory Preset: SEMAsk

Remarks: You must be in the 1xEV-DO mode to use this command. Use INSTRUMENT:SElect to set the mode.

History: PSA:
Added in version A.02.00

E4406A:
Added in version A.05.00

Spectrum Emission Mask—Measurement Interval

`[:SENSE] :SEMAsk :SWEep :TIME <time> | <no. of chips>`

`[:SENSe] :SEMAsk :SWEep :TIME?`

Specify the time length in μs or number of chips, for the measurement interval that is the data acquisition time for each bin.

Factory Preset: 1 ms

182.3 μs or 224 chips (for 1xEV-DO)

Range: 100 μs to 10 ms

10.0 μs to 10.0 ms or 12.3 to 12300 chips (for 1xEV-DO)

Default Unit: seconds

Remarks: You must be in the cdma2000, W-CDMA, or 1xEV-DO mode to use this command. Use INSTRUMENT:SElect to set the mode.

Spectrum Emission Mask—Measurement Offset

`[:SENSE] :SEMAsk :SWEep :TIME :OFFSet <time> | <no. of chips>`

`[:SENSe] :SEMAsk :SWEep :TIME :OFFSet?`

Specify the time length in μs or no. of chips offset from the measurement trigger.

Factory Preset: 325.5 μs or 400 chips

Range: 0.0 μs to 1667.0 μs or 0 to 2048 chips

Default Unit: seconds

Remarks: You must be in the 1xEV-DO mode to use this command. Use INSTRUMENT:SElect to set the mode.

History: PSA:
Added in version A.02.00

E4406A:
Added in version A.05.00

Spectrum Emission Mask—Trigger Source

[[:SENSe]:SEMAsk:TRIGger:SOURce
EXTErnal [1] | EXTErnal2 | FRAMe | IMMEDIATE | LINE

[[:SENSe]:SEMAsk:TRIGger:SOURce?

Select one of the trigger sources used to control the data acquisitions.

EXTErnal 1 – front panel external trigger input

EXTErnal 2 – rear panel external trigger input

FRAMe – internal frame trigger

IMMEDIATE – the next data acquisition is immediately taken, capturing the signal asynchronously (also called free run).

LINE – power line

Factory Preset: IMMEDIATE

Remarks: You must be in the cdma2000, W-CDMA, or 1xEV-DO mode to use this command. Use INSTRUMENT:SElect to set the mode.

Spectrum Emission Mask—Power Reference

[[:SENSe]:SEMAsk:TYPE PSDRef | TPref

[[:SENSe]:SEMAsk:TYPE?

Set the power measurement reference type. This allows you to make absolute and relative power measurements of either total power or the power normalized to the measurement bandwidth.

PSDRef - the power spectral density is used as the power reference

TPRef - the total power is used as the power reference

Factory Preset: TPRef

Remarks: You must be in the cdma2000, W-CDMA, 1xEV-DO mode to use this command. Use INSTRument:SElect to set the mode.

Spectrum (Frequency-Domain) Measurement

Commands for querying the spectrum measurement results and for setting to the default values are found in the “MEASure Group of Commands” on page 339. The equivalent front panel keys for the parameters described in the following commands, are found under the **Meas Setup** key, after the **Spectrum (Freq Domain)** measurement has been selected from the **MEASURE** key menu.

Spectrum—Data Acquisition Packing

```
[ :SENSe ] :SPECTrum:ACQuisition:PACKing  
AUTO | LONG | MEDium | SHORt
```

```
[ :SENSe ] :SPECTrum:ACQuisition:PACKing?
```

Select the amount of data acquisition packing. This is an advanced control that normally does not need to be changed.

Factory Preset: AUTO

Remarks: To use this command for E4406A, the appropriate mode should be selected with INSTRUMENT:SElect.

For PSA you must be in the Basic, cdmaOne, cdma2000, 1xEV-DO, W-CDMA, GSM, EDGE, NADC, or PDC mode to use this command. Use INSTRUMENT:SElect to set the mode.

Spectrum—ADC Dither

```
[ :SENSe ] :SPECTrum:ADC:DITHer [ :STATe ] AUTO | ON | OFF | 2 | 1 | 0
```

```
[ :SENSe ] :SPECTrum:ADC:DITHer [ :STATe ] ?
```

Turn the ADC dither on or off. This is an advanced control that normally does not need to be changed.

Factory Preset: AUTO

Remarks: To use this command for E4406A, the appropriate mode should be selected with INSTRUMENT:SElect.

For PSA you must be in the Basic, cdmaOne, cdma2000, 1xEV-DO, W-CDMA, GSM, EDGE, NADC, or PDC mode to use this command. Use INSTRUMENT:SElect to set the mode.

Spectrum—ADC Range

E4406A

```
[ :SENSe ] :SPECTrum:ADC:RANGe
```

AUTO | APEak | APLock | M6 | P0 | P6 | P12 | P18 | P24

PSA

[:SENSe] :SPECTrum:ADC:RANGe

AUTO | APEak | APLock | NONE | P0 | P6 | P12 | P18

[:SENSe] :SPECTrum:ADC:RANGe?

Select the range for the gain-ranging that is done in front of the ADC. This is an advanced control that normally does not need to be changed. Auto peak ranging is the default for this measurement. If you are measuring a CW signal please see the description below.

- AUTO - automatic range

For FFT spectrums - auto ranging should not be not be used. An exception to this would be if you know that your signal is “bursty”. Then you might use auto to maximize the time domain dynamic range as long as you are not very interested in the FFT data.

- Auto Peak (APEak) - automatically peak the range

For CW signals, the default of auto-peak ranging can be used, but a better FFT measurement of the signal can be made by selecting one of the manual ranges that are available: M6, P0 - P24.

Auto peaking can cause the ADC range gain to move monotonically down during the data capture. This movement should have negligible effect on the FFT spectrum, but selecting a manual range removes this possibility. Note that if the CW signal being measured is close to the auto-ranging threshold, the noise floor may shift as much as 6 dB from sweep to sweep.

- Auto Peak Lock (APLock) - automatically peak lock the range

For CW signals, auto-peak lock ranging may be used. It will find the best ADC measurement range for this particular signal and will not move the range as auto-peak can. Note that if the CW signal being measured is close to the auto-ranging threshold, the noise floor may shift as much as 6 dB from sweep to sweep.

For “bursty” signals, auto-peak lock ranging should not be used. The measurement will fail to operate, since the wrong (locked) ADC range will be chosen often and overloads will occur in the ADC.

- NONE - (PSA) turns off any auto-ranging without making any changes to the current setting.
- M6 - (E4406A) manually selects an ADC range that subtracts 6 dB of fixed gain across the range. Manual ranging is best for CW signals.
- P0 to P18 - (PSA) manually selects ADC ranges that add 0 to 18 dB of fixed gain across the range. Manual ranging is best for CW signals.

- P0 to 24 - (E4406A) manually selects ADC ranges that add 0 to 24 dB of fixed gain across the range. Manual ranging is best for CW signals.

Factory Preset: APEak

Remarks: To use this command for E4406A, the appropriate mode should be selected with INSTRUMENT:SElect.

For PSA you must be in the Basic, cdmaOne, cdma2000, 1xEV-DO, W-CDMA, GSM, EDGE, NADC, or PDC mode to use this command. Use INSTRUMENT:SElect to set the mode.

Spectrum—Average Clear

`[:SENSe] :SPECTrum:AVERAge:CLEar`

The average data is cleared and the average counter is reset.

Remarks: To use this command for E4406A, the appropriate mode should be selected with INSTRUMENT:SElect.

For PSA you must be in the Basic, cdmaOne, cdma2000, 1xEV-DO, W-CDMA, GSM, EDGE, NADC, or PDC mode to use this command. Use INSTRUMENT:SElect to set the mode.

Spectrum—Number of Averages

`[:SENSe] :SPECTrum:AVERAge:COUNT <integer>`

`[:SENSe] :SPECTrum:AVERAge:COUNT?`

Set the number of 'sweeps' that will be averaged. After the specified number of 'sweeps' (average counts), the averaging mode (terminal control) setting determines the averaging action.

Factory Preset: 25

Range: 1 to 10,000

Remarks: To use this command for E4406A, the appropriate mode should be selected with INSTRUMENT:SElect.

For PSA you must be in the Basic, cdmaOne, cdma2000, 1xEV-DO, W-CDMA, GSM, EDGE, NADC, or PDC mode to use this command. Use INSTRUMENT:SElect to set the mode.

Spectrum—Averaging State

`[:SENSE] :SPECTrum:AVERAge [:STATe] OFF | ON | 0 | 1`

`[:SENSE] :SPECTrum:AVERAge [:STATe] ?`

Turn averaging on or off.

Factory Preset: ON

Remarks: To use this command for E4406A, the appropriate mode should be selected with `INSTRument:SElect`.

For PSA you must be in the Basic, cdmaOne, cdma2000, 1xEV-DO, W-CDMA, GSM, EDGE, NADC, or PDC mode to use this command. Use `INSTRument:SElect` to set the mode.

Spectrum—Averaging Mode

`[:SENSE] :SPECTrum:AVERAge:TCONTRol EXPonential | REPeat`

`[:SENSE] :SPECTrum:AVERAge:TCONTRol ?`

Select the type of termination control used for the averaging function. This determines the averaging action after the specified number of ‘sweeps’ (average count) is reached.

EXPonential - Each successive data acquisition after the average count is reached, is exponentially weighted and combined with the existing average.

REPeat - After reaching the average count, the averaging is reset and a new average is started.

Factory Preset: EXPonential

Remarks: To use this command for E4406A, the appropriate mode should be selected with `INSTRument:SElect`.

For PSA you must be in the Basic, cdmaOne, cdma2000, 1xEV-DO, W-CDMA, GSM, EDGE, NADC, or PDC mode to use this command. Use `INSTRument:SElect` to set the mode.

Spectrum—Averaging Type

`[:SENSE] :SPECTrum:AVERAge:TYPE
LOG | MAXimum | MINimum | RMS | SCALar`

`[:SENSE] :SPECTrum:AVERAge:TYPE?`

Select the type of averaging.

LOG – The log of the power is averaged. (This is also known as video averaging.)

MAXimum – The maximum values are retained.

MINimum – The minimum values are retained.

RMS – The power is averaged, providing the rms of the voltage.

SCALar – The voltage is averaged.

Factory Preset: LOG

Remarks: To use this command for E4406A, the appropriate mode should be selected with INSTRUMENT:SElect.

For PSA you must be in the Basic, cdmaOne, cdma2000, 1xEV-DO, W-CDMA, GSM, EDGE, NADC, or PDC mode to use this command. Use INSTRUMENT:SElect to set the mode.

Spectrum— Select Pre-FFT Bandwidth

```
[ :SENSe ] :SPECTrum: BANDwidth | BWIDth: IF: AUTO OFF | ON | 0 | 1
```

```
[ :SENSe ] :SPECTrum: BANDwidth | BWIDth: IF: AUTO?
```

Select auto or manual control of the pre-FFT BW.

Factory Preset: AUTO, 1.55 MHz

Remarks: To use this command for E4406A, the appropriate mode should be selected with INSTRUMENT:SElect.

For PSA you must be in the Basic, cdmaOne, cdma2000, 1xEV-DO, W-CDMA, GSM, EDGE, NADC, or PDC mode to use this command. Use INSTRUMENT:SElect to set the mode.

Front Panel

Access: **Measure, Spectrum, Meas Setup, More, Advanced, Pre-FFT BW.**

Spectrum — IF Flatness Corrections

```
[ :SENSe ] :SPECTrum: BANDwidth | BWIDth: IF: FLATness OFF | ON | 0 | 1
```

```
[ :SENSe ] :SPECTrum: BANDwidth | BWIDth: IF: FLATness?
```

Turns IF flatness corrections on and off.

Factory Preset: ON

Remarks: To use this command for E4406A, the appropriate mode should be selected with INSTRUMENT:SElect.

For PSA you must be in the Basic, cdmaOne, cdma2000, 1xEV-DO, W-CDMA, GSM, EDGE, NADC, or PDC mode to use this command. Use INSTRument:SElect to set the mode.

Front Panel

Access: **Measure, Spectrum, Meas Setup, More, Advanced, Pre-FFT BW**

Spectrum—Pre-ADC Bandpass Filter

```
[ :SENSe ] :SPECTrum: BANDwidth | BWIDth: PADC OFF | ON | 0 | 1
```

```
[ :SENSe ] :SPECTrum: BANDwidth | BWIDth: PADC ?
```

Turn the pre-ADC bandpass filter on or off. This is an advanced control that normally does not need to be changed.

Remarks: To use this command for E4406A, the appropriate mode should be selected with INSTRument:SElect.

For PSA you must be in the Basic, cdmaOne, cdma2000, 1xEV-DO, W-CDMA, GSM, EDGE, NADC, or PDC mode to use this command. Use INSTRument:SElect to set the mode.

Spectrum—Pre-FFT BW

```
[ :SENSe ] :SPECTrum: BANDwidth | BWIDth: PFFT [ :SIZE ] <freq>
```

```
[ :SENSe ] :SPECTrum: BANDwidth | BWIDth: PFFT [ :SIZE ] ?
```

Set the pre-FFT bandwidth. This is an advanced control that normally does not need to be changed.

Frequency span, resolution bandwidth, and the pre-FFT bandwidth settings are normally coupled. If you are not auto-coupled, there can be combinations of these settings that are not valid.

Factory Preset: 1.55 MHz

1.25 MHz for cdmaOne

155.0 kHz, for iDEN mode (E4406A)

Range: 1 Hz to 10.0 MHz

Remarks: To use this command for E4406A, the appropriate mode should be selected with INSTRument:SElect.

For PSA you must be in the Basic, cdmaOne, cdma2000, 1xEV-DO, W-CDMA, GSM, EDGE, NADC, or PDC mode to use this command. Use INSTRument:SElect to

set the mode.

Spectrum—Pre-FFT BW Filter Type

```
[ :SENSe ] :SPECTrum: BANDwidth | BWIDth: PFFT: TYPE FLAT | GAUSSian
```

```
[ :SENSe ] :SPECTrum: BANDwidth | BWIDth: PFFT: TYPE?
```

Select the type of pre-FFT filter that is used. This is an advanced control that normally does not need to be changed.

Flat top (FLAT)- a filter with a flat amplitude response, which provides the best amplitude accuracy.

GAUSSian - a filter with Gaussian characteristics, which provides the best pulse response.

Factory Preset: FLAT

Remarks: To use this command for E4406A, the appropriate mode should be selected with INSTRUMENT:SElect.

For PSA you must be in the Basic, cdmaOne, cdma2000, 1xEV-DO, W-CDMA, GSM, EDGE, NADC, or PDC mode to use this command. Use INSTRUMENT:SElect to set the mode.

Spectrum—Resolution BW

```
[ :SENSe ] :SPECTrum: BANDwidth | BWIDth [ :RESolution ] <freq>
```

```
[ :SENSe ] :SPECTrum: BANDwidth | BWIDth [ :RESolution ] ?
```

Set the resolution bandwidth for the FFT. This is the bandwidth used for resolving the FFT measurement. It is not the pre-FFT bandwidth. This value is ignored if the function is auto-coupled.

Frequency span, resolution bandwidth, and the pre-FFT bandwidth settings are normally coupled. If you are not auto-coupled, there can be combinations of these settings that are not valid.

Factory Preset: 20.0 kHz

250.0 Hz, for iDEN mode (E4406A)

Range: 0.10 Hz to 3.0 MHz

Remarks: To use this command for E4406A, the appropriate mode should be selected with INSTRUMENT:SElect.

For PSA you must be in the Basic, cdmaOne, cdma2000, 1xEV-DO, W-CDMA, GSM, EDGE, NADC, or PDC mode to use this command. Use INSTRUMENT:SElect to set the mode.

Spectrum—Resolution BW Auto

```
[ :SENSE ] :SPECTrum: BANDwidth | BWIDth [ :RESolution ] :AUTO  
OFF | ON | 0 | 1
```

```
[ :SENSe ] :SPECTrum: BANDwidth | BWIDth [ :RESolution ] :AUTO?
```

Select auto or manual control of the resolution BW. The automatic mode couples the resolution bandwidth setting to the frequency span.

Factory Preset: ON

OFF, for iDEN mode (E4406A)

Remarks: To use this command for E4406A, the appropriate mode should be selected with INSTRUMENT:SElect.

For PSA you must be in the Basic, cdmaOne, cdma2000, W-CDMA, GSM, EDGE, NADC, or PDC mode to use this command. Use INSTRUMENT:SElect to set the mode.

Decimation of Spectrum Display

```
[ :SENSe ] :SPECTrum: DECimate [ :FACTor ] <integer>
```

```
[ :SENSe ] :SPECTrum: DECimate [ :FACTor ] ?
```

Sets the amount of data decimation done by the hardware and/or the software. Decimation by n keeps every nth sample, throwing away each of the remaining samples in the group of n. For example, decimation by 3 keeps every third sample, throwing away the two in between. Similarly, decimation by 5 keeps every fifth sample, throwing away the four in between.

Using zero (0) decimation selects the automatic mode. The measurement will then automatically choose decimation by “1” or “2” as is appropriate for the bandwidth being used.

This is an advanced control that normally does not need to be changed.

Factory Preset: 0

Range: 0 to 1,000, where 0 sets the function to automatic

Remarks: To use this command for E4406A, the appropriate mode should be selected with INSTRUMENT:SElect.

For PSA you must be in the Basic, cdmaOne, cdma2000, 1xEV-DO, W-CDMA, GSM, EDGE, NADC, or PDC mode to use this command. Use INSTRUMENT:SElect to set the mode.

History: E4406A:
Version A.02.00 or later

Spectrum—FFT Length

`[:SENSe] :SPECTrum:FFT:LENGth <integer>`

`[:SENSe] :SPECTrum:FFT:LENGth?`

Set the FFT length. This value is only used if length control is set to manual. The value must be greater than or equal to the window length value. Any amount greater than the window length is implemented by zero-padding. This is an advanced control that normally does not need to be changed.

Factory Preset: 706

Range: min, depends on the current setting of the spectrum window length
max, 1,048,576

Remarks: To use this command for E4406A, the appropriate mode should be selected with `INSTRument:SElect`.

For PSA you must be in the Basic, cdmaOne, cdma2000, 1xEV-DO, W-CDMA, GSM, EDGE, NADC, or PDC mode to use this command. Use `INSTRument:SElect` to set the mode.

History: E4406A:
Short form changed from `LENGth` to `LENGth`, A.03.00

Spectrum—FFT Length Auto

`[:SENSe] :SPECTrum:FFT:LENGth:AUTO OFF | ON | 0 | 1`

`[:SENSe] :SPECTrum:FFT:LENGth:AUTO?`

Select auto or manual control of the FFT and window lengths.

This is an advanced control that normally does not need to be changed.

On - the window lengths are coupled to resolution bandwidth, window type (FFT), pre-FFT bandwidth (sample rate) and `SENSe:SPECTrum:FFT:RBWPoints`.

Off - lets you set `SENSe:SPECTrum:FFT:LENGth` and `SENSe:SPECTrum:FFT:WINDow:LENGth`.

Factory Preset: ON

Remarks: To use this command for E4406A, the appropriate mode should be selected with `INSTRument:SElect`.

For PSA you must be in the Basic, cdmaOne, cdma2000, 1xEV-DO, W-CDMA, GSM, EDGE, NADC, or PDC mode to use this command. Use INSTRument:SElect to set the mode.

History: E4406A:
Short form changed from LENgth to LENGth, A.03.00

Spectrum—FFT Minimum Points in Resolution BW

`[:SENSe] :SPECTrum:FFT:RBWPoints <real>`

`[:SENSe] :SPECTrum:FFT:RBWPoints?`

Set the minimum number of data points that will be used inside the resolution bandwidth. The value is ignored if length control is set to manual. This is an advanced control that normally does not need to be changed.

Factory Preset: 1.30

Range: 0.1 to 100

Remarks: To use this command for E4406A, the appropriate mode should be selected with INSTRument:SElect.

For PSA you must be in the Basic, cdmaOne, cdma2000, 1xEV-DO, W-CDMA, GSM, EDGE, NADC, or PDC mode to use this command. Use INSTRument:SElect to set the mode.

Spectrum—Window Delay

`[:SENSe] :SPECTrum:FFT:WINDow:DElAY <real>`

`[:SENSe] :SPECTrum:FFT:WINDow:DElAY?`

Set the FFT window delay to move the FFT window from its nominal position of being centered within the time capture. This function is not available from the front panel. It is an advanced control that normally does not need to be changed.

Factory Preset: 0

Range: -10.0 to +10.0s

Default Unit: seconds

Remarks: To use this command for E4406A, the appropriate mode should be selected with INSTRument:SElect.

For PSA you must be in the Basic, cdmaOne, cdma2000, 1xEV-DO, W-CDMA, GSM, EDGE, NADC, or PDC

mode to use this command. Use INSTRument:SElect to set the mode.

Spectrum—Window Length

[:SENSe] :SPEctrum:FFT:WINDow:LENGth <integer>

[:SENSe] :SPEctrum:FFT:WINDow:LENGth?

Set the FFT window length. This value is only used if length control is set to manual. This is an advanced control that normally does not need to be changed.

Factory Preset: 706

Range: 8 to 1,048,576

Remarks: To use this command for E4406A, the appropriate mode should be selected with INSTRument:SElect.

For PSA you must be in the Basic, cdmaOne, cdma2000, 1xEV-DO, W-CDMA, GSM, EDGE, NADC, or PDC mode to use this command. Use INSTRument:SElect to set the mode.

History: E4406A:
Short form changed from LENgth to LENGth, A.03.00

Spectrum—FFT Window

[:SENSe] :SPEctrum:FFT:WINDow [:TYPE]

BH4Tap | BLACkman | FLATtop | GAUSSian | HAMMING | HANNing | KB70 | KB90 | KB110 | UNIFORM

[:SENSe] :SPEctrum:FFT:WINDow [:TYPE] ?

Select the FFT window type.

BH4Tap - Blackman Harris with 4 taps

BLACkman - Blackman

FLATtop - flat top, the default (for high amplitude accuracy)

GAUSSian - Gaussian with alpha of 3.5

HAMMING - Hamming

HANNing - Hanning

KB70, 90, and 110 - Kaiser Bessel with sidelobes at -70, -90, or -110 dBc

UNIFORM - no window is used. (This is the unity response.)

Factory Preset: FLATtop

Remarks: This selection affects the acquisition point quantity and the FFT size, based on the resolution bandwidth selected.

To use this command for E4406A, the appropriate mode should be selected with INSTRUMENT:SELECT.

For PSA you must be in the Basic, cdmaOne, cdma2000, 1xEV-DO, W-CDMA, GSM, EDGE, NADC, or PDC mode to use this command. Use INSTRUMENT:SELECT to set the mode.

Spectrum—Frequency Span

```
[ :SENSE ] :SPECTrum:FREQuency:SPAN <freq>
```

```
[ :SENSE ] :SPECTrum:FREQuency:SPAN?
```

Set the frequency span to be measured.

Factory Preset: 1.0 MHz

100.0 kHz for iDEN mode (E4406A)

Range: 10 Hz to 10.0 MHz (15 MHz when Service mode is selected)

Default Unit: Hz

Remarks: The actual measured span will generally be slightly wider due to the finite resolution of the FFT.

To use this command for E4406A, the appropriate mode should be selected with INSTRUMENT:SELECT.

For PSA you must be in the Basic, cdmaOne, cdma2000, 1xEV-DO, W-CDMA, GSM, EDGE, NADC, or PDC mode to use this command. Use INSTRUMENT:SELECT to set the mode.

Spectrum—Sweep (Acquisition) Time

```
[ :SENSE ] :SPECTrum:SWEep:TIME [ :VALue ] <time>
```

```
[ :SENSE ] :SPECTrum:SWEep:TIME?
```

Set the sweep (measurement acquisition) time. It is used to specify the length of the time capture record. If the value you specify is less than the capture time required for the specified span and resolution bandwidth, the value is ignored. The value is set at its auto value when auto is selected. This is an advanced control that normally does not

need to be changed.

Factory Preset: 188.0 μ s

15.059 ms, for iDEN mode (E4406A)

Range: 100 ns to 10 s

Default Unit: seconds

Remarks: To use this command for E4406A, the appropriate mode should be selected with INSTRUMENT:SElect.

For PSA you must be in the Basic, cdmaOne, cdma2000, 1xEV-DO, W-CDMA, GSM, EDGE, NADC, or PDC mode to use this command. Use INSTRUMENT:SElect to set the mode.

Spectrum—Sweep (Acquisition) Time Auto

```
[ :SENSe ] :SPECTrum:SWEep:TIME:AUTO OFF | ON | 0 | 1
```

```
[ :SENSe ] :SPECTrum:SWEep:TIME:AUTO
```

Select auto or manual control of the sweep (acquisition) time. This is an advanced control that normally does not need to be changed.

AUTO - couples the Sweep Time to the Frequency Span and Resolution BW

Manual - the Sweep Time is uncoupled from the Frequency Span and Resolution BW.

Factory Preset: AUTO

Remarks: To use this command for E4406A, the appropriate mode should be selected with INSTRUMENT:SElect.

For PSA you must be in the Basic, cdmaOne, cdma2000, 1xEV-DO, W-CDMA, GSM, EDGE, NADC, or PDC mode to use this command. Use INSTRUMENT:SElect to set the mode.

Spectrum—Trigger Source

```
[ :SENSe ] :SPECTrum:TRIGger:SOURce  
EXTernal [1] | EXTernal2 | FRAME | IF | LINE | IMMEDIATE | RFBurst
```

```
[ :SENSe ] :SPECTrum:TRIGger:SOURce?
```

Select the trigger source used to control the data acquisitions.

EXTernal1 - front panel external trigger input

EXTernal2 - rear panel external trigger input

FRAMe - internal frame timer from front panel input

IF - internal IF envelope (video) trigger

LINE - internal line trigger

IMMEDIATE - the next data acquisition is immediately taken (also called free run)

RFBurst - wideband RF burst envelope trigger that has automatic level control for periodic burst signals

Factory Preset: IMMEDIATE (free run)

RFBurst, for GSM, iDEN mode

Remarks: To use this command for E4406A, the appropriate mode should be selected with INSTRUMENT:SELECT.

For PSA you must be in the Basic, cdmaOne, cdma2000, 1xEV-DO, W-CDMA, GSM, EDGE, NADC, or PDC mode to use this command. Use INSTRUMENT:SELECT to set the mode.

Terminal Code Domain Measurement

Commands for querying the terminal code domain measurement results and for setting to the default values are found in the “MEASure Group of Commands” on page 339.

Terminal Code Domain Measurement–Active Code Channel

```
[ :SENSe ] :TCDPower:ACode AUTO|COMBination|PREDefined
```

```
[ :SENSe ] :TCDPower:ACode?
```

Set the reverse link active code detection mode.

- **AUTO** - It is automatically detected (by internal algorithm) whether or not channel is active.
- **COMBination** - Channel specified by predefined (Pilot/DRC/ACK/Data) whether or not it is active automatically (by internal algorithm).
- **PREDefined** - It is decided by predefined information (Pilot/DRC/ACK/Data) whether or not channel is active.

Factory Preset: AUTO

Remarks: You must be in the 1xEV-DO mode to use this command. Use INSTRument:SElect to set the mode.

Terminal Code Domain Measurement–ACK Channel Definition

```
[ :SENSe ] :TCDPower:ACode:ACK OFF|ON|0|1
```

```
[ :SENSe ] :TCDPower:ACode:ACK?
```

Set the reverse link ACK channel to active (On) or inactive (Off).

- **On** - Reverse link ACK is set to active.
- **Off** - Reverse link ACK is set to inactive.

Factory Preset: On

Remarks: You must be in the 1xEV-DO mode to use this command. Use INSTRument:SElect to set the mode.

Terminal Code Domain Measurement–Data Channel Definition

```
[ :SENSe ] :TCDPower:ACode:DATA OFF|ON|0|1
```

```
[ :SENSe ] :TCDPower:ACode:DATA?
```

Set the reverse link data channel to active (On) or inactive (Off).

- **On** - Reverse link data is set to active.

- Off - Reverse link data is set to inactive.

Factory Preset: On

Remarks: You must be in the 1xEV-DO mode to use this command. Use INSTRUMENT:SElect to set the mode.

Terminal Code Domain Measurement–DRC Channel Definition

```
[ :SENSE ] :TCDPower :ACODE :DRC OFF | ON | 0 | 1
```

```
[ :SENSE ] :TCDPower :ACODE :DRC?
```

Set the reverse link DRC channel to active (On) or inactive (Off).

- On - Reverse link DRC is set to active.
- Off - Reverse link DRC is set to inactive.

Factory Preset: On

Remarks: You must be in the 1xEV-DO mode to use this command. Use INSTRUMENT:SElect to set the mode.

Terminal Code Domain Measurement–Pilot Channel Definition

```
[ :SENSE ] :TCDPower :ACODE :PILOt OFF | ON | 0 | 1
```

```
[ :SENSE ] :TCDPower :ACODE :PILOt?
```

Set the reverse link pilot channel to active (On) or inactive (Off).

- On - Reverse link pilot is set to active.
- Off - Reverse link pilot is set to inactive.

Factory Preset: On

Remarks: You must be in the 1xEV-DO mode to use this command. Use INSTRUMENT:SElect to set the mode.

Terminal Code Domain Measurement–ADC Range

```
[ :SENSE ] :TCDPower :ADC :RANGe
```

```
AUTO | APEak | APLOck | NONE | P0 | P6 | P12 | P18 | P24 | M6
```

```
[ :SENSE ] :TCDPower :ADC :RANGe?
```

Select a ranging function for the ADC gain control. This is an advanced control that normally does not need to be changed. If you are measuring a CW signal, see the following description.

- AUTO - This is automatic ranging. For FFT spectrums the auto ranging should not be used. An exception to this is if you know that

your signal is “bursty,” then you can use auto to maximize the time domain dynamic range as long as you are not very interested in the FFT data.

- **APEak (Auto Peak)** - This is automatic ranging to the peak signal level. For CW signals the default of auto-peak ranging can be used. However, a better FFT measurement of the signal can be made by selecting one of the manual ranges available by specifying NONE, or P0 through P18. Auto peaking can cause the ADC gain to monotonically track the ranges down during the data capture. This tracking effect should be negligible for the FFT spectrum, but selecting a manual range solves this possibility. If the CW signal being measured is close to the auto-ranging threshold, the noise floor may shift as much as 6 dB every sweep.
- **APLock (Auto Peak Lock)** - This is automatic ranging locked to the peak signal level. For CW signals, auto-peak lock ranging may be used. It will find the ADC gain most appropriate for this particular signal and will not track the ranges as auto peak can. If the CW signal being measured is close to the auto-ranging threshold, the noise floor may shift as much as 6 dB every sweep. For “bursty” signals, auto peak lock ranging should not be used. Since the ADC range can often be locked to the wrong one (resulting in overloading the ADC) the measurement will fail.
- **NONE** - This turns off any auto-ranging without making any changes to the current setting. This is not applicable for use with an Agilent VSA having a 12-bit ADC Board).
- **P0 through P18, P24, M6** - Manually selects one of the ADC ranges that add 0 dB (P0) to 18 dB (P18) and –6 dB (M6), 24 dB (P24) to the fixed gain across the range. Manual ranging is best for CW signals. M6 and P24 are applicable only for Agilent VSA analyzers having a 14-bit ADC board.

Factory Preset: NONE for Agilent PSA analyzers, including Agilent VSA analyzers with the 14-bit ADC board.

M6 for Agilent VSA analyzers with the 12-bit ADC board.

Remarks: You must be in the 1xEV-DO mode to use this command. Use INSTRument:SElect to set the mode.

Terminal Code Domain Measurement–Data Capture Time

```
[[:SENSe]:TCDPower:CAPTure:TIME <integer>
```

```
[[:SENSe]:TCDPower:CAPTure:TIME?
```

Set the length of data capture in slots that will be used in the acquisition (1 slot = 1.667 ms).

Factory Preset: 5

Range: 2 to 32 slots (3.333 ms to 53.333 ms)

Remarks: You must be in the 1xEV-DO mode to use this command. Use INSTRUMENT:SElect to set the mode.

Terminal Code Domain Measurement–Chip Rate

```
[ :SENSE ] :TCDPower:CRATe <freq>
```

```
[ :SENSE ] :TCDPower:CRATe?
```

Set the chip rate.

Factory Preset: 1.2288 MHz

Range: 1.10592 MHz to 1.35168 MHz (default $\pm 10\%$)

Resolution: 1 Hz

Step: 1 kHz

Remarks: You must be in the 1xEV-DO mode to use this command. Use INSTRUMENT:SElect to set the mode.

Terminal Code Domain Measurement Trigger Source

```
[ :SENSE ] :TCDPower:TRIGger:SOURce
```

```
EXTeRnal [1] | EXTeRnal2 | IMMEDIATE | RFBURSt | IF | FRAMe
```

```
[ :SENSE ] :TCDPower:TRIGger:SOURce?
```

Set the trigger source used to control the data acquisitions.

- EXTeRnal[1] - Front panel external trigger input
- EXTeRnal2 - Rear panel external trigger input
- IMMEDIATE - The next data acquisition is immediately taken, capturing the signal asynchronously (also called Free Run).
- RFBURSt - Internal wideband RF burst envelope trigger that has automatic level control for periodic burst signals.
- IF - Internal IF envelope trigger.
- FRAMe - Internal frame trigger.

Factory Preset: IMMEDIATE

Remarks: You must be in the 1xEV-DO mode to use this command. Use INSTRUMENT:SElect to set the mode.

Terminal Code Domain Measurement–Spectrum Normal/Invert

```
[ :SENSe ] :TCDPower :SPECTrum NORMal | INVert
```

```
[ :SENSe ] :TCDPower :SPECTrum?
```

Select normal or inverted spectrum for the demodulation-related measurements.

NORMal - normal

INVert - The upper and lower spectrum are swapped

Factory Preset: NORMal

Range: 1.10592 MHz to 1.35168 MHz (default $\pm 10\%$)

Remarks: You must be in the 1xEV-DO mode to use this command. Use INSTRument:SELEct to set the mode.

Terminal Code Domain Measurement–I Long Code Mask

```
[ :SENSe ] :TCDPower :SYNC :ILCMask <long_integer>
```

```
[ :SENSe ] :TCDPower :SYNC :ILCMask?
```

Set the I long code mask for CDP.

Factory Preset: 0x0

Range: 0x0 to 0x3ff ffff ffff (42 bits)

Remarks: You must be in the 1xEV-DO mode to use this command. Use INSTRument:SELEct to set the mode.

Terminal Code Domain Measurement–Q Long Code Mask

```
[ :SENSe ] :TCDPower :SYNC :QLCMask <long_integer>
```

```
[ :SENSe ] :TCDPower :SYNC :QLCMask?
```

Set the Qlong code mask for CDP.

Factory Preset: 0x0

Range: 0x0 to 0x3ff ffff ffff (42 bits)

Remarks: You must be in the 1xEV-DO mode to use this command. Use INSTRument:SELEct to set the mode.

Terminal Modulation Accuracy Measurement

Commands for querying the terminal modulation accuracy measurement results and for setting to the default values are found in the “MEASure Group of Commands” on page 1.

Terminal Modulation Accuracy Measurement–Active Code Channel

**[[:SENSe]:TRHO:ACODE AUTO | COMBination | PREDefined
[:SENSe]:TRHO:ACODE?**

Set the reverse link active code detection mode.

- AUTO - It is automatically detected (by internal algorithm) whether or not channel is active.
- COMBination - Channel specified by predefined (Pilot/DRC/ACK/Data) whether or not it is active automatically (by internal algorithm).
- PREDefined - It is decided by predefined information (Pilot/DRC/ACK/Data) whether or not channel is active.

Factory Preset: AUTO

Remarks: You must be in the 1xEV-DO mode to use this command. Use INSTRument:SElect to set the mode.

Terminal Modulation Accuracy Measurement–ACK Channel Definition

**[[:SENSe]:TRHO:ACODE:ACK OFF | ON | 0 | 1
[:SENSe]:TRHO:ACODE:ACK?**

Set the reverse link ACK channel to active (On) or inactive (Off).

- On - Reverse link ACK is set to active.
- Off - Reverse link ACK is set to inactive.

Factory Preset: On

Remarks: You must be in the 1xEV-DO mode to use this command. Use INSTRument:SElect to set the mode.

Terminal Modulation Accuracy Measurement–Data Channel Definition

**[[:SENSe]:TRHO:ACODE:DATA OFF | ON | 0 | 1
[:SENSe]:TRHO:ACODE:DATA?**

Set the reverse link data channel to active (On) or inactive (Off).

- On - Reverse link data is set to active.
- Off - Reverse link data is set to inactive.

Factory Preset: On

Remarks: You must be in the 1xEV-DO mode to use this command. Use INSTRUMENT:SElect to set the mode.

Terminal Modulation Accuracy Measurement–DRC Channel Definition

[[:SENSe]:TRHO:ACODE:DRC OFF | ON | 0 | 1

[[:SENSe]:TRHO:ACODE:DRC?

Set the reverse link DRC channel to active (On) or inactive (Off).

- On - Reverse link DRC is set to active.
- Off - Reverse link DRC is set to inactive.

Factory Preset: On

Remarks: You must be in the 1xEV-DO mode to use this command. Use INSTRUMENT:SElect to set the mode.

Terminal Modulation Accuracy Measurement–Pilot Channel Definition

[[:SENSe]:TRHO:ACODE:PILOt OFF | ON | 0 | 1

[[:SENSe]:TRHO:ACODE:PILOt?

Set the reverse link pilot channel to active (On) or inactive (Off).

- On - Reverse link pilot is set to active.
- Off - Reverse link pilot is set to inactive.

Factory Preset: On

Remarks: You must be in the 1xEV-DO mode to use this command. Use INSTRUMENT:SElect to set the mode.

Terminal Modulation Accuracy Measurement–ADC Range

[[:SENSe]:TRHO:ADC:RANGe

AUTO | APEak | APLOck | NONE | P0 | P6 | P12 | P18 | P24 | M6

[[:SENSe]:TRHO:ADC:RANGe?

Select a ranging function for the ADC gain control. This is an advanced control that normally does not need to be changed. If you are measuring a CW signal, see the following description.

- **AUTO** - This is automatic ranging. For FFT spectrums the auto ranging should not be used. An exception to this is if you know that your signal is “bursty,” then you can use auto to maximize the time domain dynamic range as long as you are not very interested in the FFT data.
- **APEak (Auto Peak)** - This is automatic ranging to the peak signal level. For CW signals the default of auto-peak ranging can be used. However, a better FFT measurement of the signal can be made by selecting one of the manual ranges available by specifying NONE, or P0 through P18. Auto peaking can cause the ADC gain to monotonically track the ranges down during the data capture. This tracking effect should be negligible for the FFT spectrum, but selecting a manual range solves this possibility. If the CW signal being measured is close to the auto-ranging threshold, the noise floor may shift as much as 6 dB every sweep.
- **APLock (Auto Peak Lock)** - This is automatic ranging locked to the peak signal level. For CW signals, auto-peak lock ranging may be used. It will find the ADC gain most appropriate for this particular signal and will not track the ranges as auto peak can. If the CW signal being measured is close to the auto-ranging threshold, the noise floor may shift as much as 6 dB every sweep. For “bursty” signals, auto peak lock ranging should not be used. Since the ADC range can often be locked to the wrong one (resulting in overloading the ADC) the measurement will fail.
- **NONE** - This turns off any auto-ranging without making any changes to the current setting. This is not applicable for use with an Agilent VSA having a 12-bit ADC Board).
- **P0 through P18, P24, M6** - Manually selects one of the ADC ranges that add 0 dB (P0) to 18 dB (P18) and –6 dB (M6), 24 dB (P24) to the fixed gain across the range. Manual ranging is best for CW signals. M6 and P24 are applicable only for Agilent VSA analyzers having a 14-bit ADC board.

Factory Preset: NONE for Agilent PSA analyzers, including Agilent VSA analyzers with the 14-bit ADC board.

M6 for Agilent VSA analyzers with the 12-bit ADC board.

Remarks: You must be in the 1xEV-DO mode to use this command. Use INSTRUMENT:SELEct to set the mode.

Terminal Modulation Accuracy Measurement–Active Set Threshold

[[:SENSe]:TRHO:ASET:THReshold <numeric>

[[:SENSe]:TRHO:ASET:THReshold?

Set the Active Threshold level for the active channel identification function in dB.

Factory Preset: 0.0 dB

Range: –100.0 to 0.0 dB

Remarks: You must be in the 1xEV-DO mode to use this command. Use INSTRument:SElect to set the mode.

Terminal Modulation Accuracy Measurement–Average Count

[[:SENSe]:TRHO:AVERAge:COUNT <integer>

[[:SENSe]:TRHO:AVERAge:COUNT?

Set the number of data acquisitions that will be averaged. After the specified number of average counts, the average mode (termination control) setting determines the average action.

Factory Preset: 10

Range: 1 to 10,000

Remarks: You must be in the 1xEV-DO mode to use this command. Use INSTRument:SElect to set the mode.

Terminal Modulation Accuracy Measurement–Averaging State

[[:SENSe]:TRHO:AVERAge[:STATe] OFF | ON | 0 | 1

[[:SENSe]:TRHO:AVERAge[:STATe]?

Turn average On or Off.

Factory Preset: On

Remarks: You must be in the 1xEV-DO mode to use this command. Use INSTRument:SElect to set the mode.

Terminal Modulation Accuracy Measurement–Averaging Termination Control

[[:SENSe]:TRHO:AVERAge:TCONtrol EXPonential | REPeat

[[:SENSe]:TRHO:AVERAge:TCONtrol?

Select the type of termination control used for averaging. This determines the averaging action after the specified number of data acquisitions (average count) is reached.

- **EXponential** - After the average count is reached each successive data acquisition is exponentially weighted and combined with the existing average.
- **REPeat** - After the average count is reached the averaging is reset and a new average is started.

Factory Preset: REPeat

Remarks: You must be in the 1xEV-DO mode to use this command. Use INSTRument:SElect to set the mode.

Terminal Modulation Accuracy Measurement–Chip Rate

[[:SENSe]:TRHO:CRATe <freq>

[[:SENSe]:TRHO:CRATe?

Set the chip rate.

Factory Preset: 1.2288 MHz

Range: 1.10592 MHz to 1.35168 MHz (default $\pm 10\%$)

Resolution: 1 Hz

Step: 1 kHz

Remarks: You must be in the 1xEV-DO mode to use this command. Use INSTRument:SElect to set the mode.

Terminal Modulation Accuracy Measurement–Averaging State

[[:SENSe]:TRHO:AVERAge[:STATe] OFF | ON | 0 | 1

[[:SENSe]:TRHO:AVERAge[:STATe]?

Turn average On or Off.

Factory Preset: On

Remarks: You must be in the 1xEV-DO mode to use this command. Use INSTRument:SElect to set the mode.

Terminal Modulation Accuracy Measurement– Spectrum Normal/Invert

[[:SENSe]:TRHO:SPECTrum NORMal | INVert

[[:SENSe]:TRHO:SPECTrum?

Select normal or inverted spectrum for demodulation related measurements.

- NORMal - normal
- INVert - The Upper and Lower sidebands are reversed in position

Factory Preset: NORMal

Remarks: You must be in the 1xEV-DO mode to use this command. Use INSTRument:SElect to set the mode.

Terminal Modulation Accuracy Measurement–I Long Code Mask

[[:SENSe]:TRHO:SYNC:ILCMask <long_integer>

[[:SENSe]:TRHO:SYNC:ILCMask?

Set the I long code mask for RHO.

Factory Preset: 0x0

Range: 0x0 to 0x3ff ffff ffff (42 bits)

Remarks: You must be in the 1xEV-DO mode to use this command. Use INSTRument:SElect to set the mode.

Terminal Modulation Accuracy Measurement–Q Long Code Mask

[[:SENSe]:TRHO:SYNC:QLCMask <long_integer>

[[:SENSe]:TRHO:SYNC:QLCMask?

Set the Qlong code mask for RHO.

Factory Preset: 0x0

Range: 0x0 to 0x3ff ffff ffff (42 bits)

Remarks: You must be in the 1xEV-DO mode to use this command. Use INSTRument:SElect to set the mode.

Terminal Modulation Accuracy Measurement Trigger Source

[[:SENSe]:TRHO:TRIGger:SOURce

EXTernal[1] | EXTernal2 | IMMEDIATE | RFBurst | IF | FRAME

[[:SENSe]:TRHO:TRIGger:SOURce?

Set the trigger source used to control the data acquisitions.

- EXTERNAL[1] - Front panel external trigger input
- EXTERNAL2 - Rear panel external trigger input
- IMMEDIATE - The next data acquisition is immediately taken, capturing the signal asynchronously (also called Free Run).
- RFBURST - Internal wideband RF burst envelope trigger that has automatic level control for periodic burst signals.
- IF - Internal IF envelope trigger.
- FRAME - Internal frame trigger.

Factory Preset: IMMEDIATE

Remarks: You must be in the 1xEV-DO mode to use this command. Use INSTRUMENT:SELECT to set the mode.

Waveform (Time-Domain) Measurement

Commands for querying the waveform measurement results and for setting to the default values are found in the “[MEASure Group of Commands](#)” on page 339. The equivalent front panel keys for the parameters described in the following commands, are found under the **Meas Setup** key, after the **Waveform (Time Domain)** measurement has been selected from the **MEASURE** key menu.

Waveform—Data Acquisition Packing

```
[ :SENSe ] :WAVEform:ACQuisition:PACKing AUTO | LONG | MEDium | SHORt
```

```
[ :SENSe ] :WAVEform:ACQuisition:PACKing?
```

This is an advanced control that normally does not need to be changed.

Factory Preset: AUTO

Remarks: To use this command for E4406A, the appropriate mode should be selected with `INSTRument:SElect`.

For PSA you must be in the Basic, `cdmaOne`, `cdma2000`, `1xEV-DO`, `W-CDMA`, `GSM`, `EDGE`, `NADC`, or `PDC` mode to use this command. Use `INSTRument:SElect` to set the mode.

Waveform—ADC Dither State

```
[ :SENSe ] :WAVEform:ADC:DITHer [ :STATe ] OFF | ON | 0 | 1
```

```
[ :SENSe ] :WAVEform:ADC:DITHer [ :STATe ] ?
```

This is an Advanced control that normally does not need to be changed.

Factory Preset: OFF

Remarks: To use this command for E4406A, the appropriate mode should be selected with `INSTRument:SElect`.

For PSA you must be in the Basic, `cdmaOne`, `cdma2000`, `1xEV-DO`, `W-CDMA`, `GSM`, `EDGE`, `NADC`, or `PDC` mode to use this command. Use `INSTRument:SElect` to set the mode.

Waveform—Pre-ADC Bandpass Filter

```
[ :SENSe ] :WAVEform:ADC:FILTer [ :STATe ] OFF | ON | 0 | 1
```

```
[ :SENSe ] :WAVEform:ADC:FILTer [ :STATe ] ?
```

Turn the pre-ADC bandpass filter on or off. This is an Advanced control that normally does not need to be changed.

Preset: OFF

Remarks: To use this command for E4406A, the appropriate mode should be selected with INSTRUMENT:SElect.

For PSA you must be in the Basic, cdmaOne, cdma2000, 1xEV-DO, W-CDMA, GSM, EDGE, NADC, or PDC mode to use this command. Use INSTRUMENT:SElect to set the mode.

Waveform—ADC Range

E4406A

[:SENSe] :WAVeform:ADC:RANGe
 AUTO | APEak | APLOCK | GROund | M6 | P0 | P6 | P12 | P18 | P24

PSA

[:SENSe] :WAVeform:ADC:RANGe
 AUTO | APEak | APLOCK | GROund | NONE | P0 | P6 | P12 | P18

[:SENSe] :WAVeform:ADC:RANGe?

Select the range for the gain-ranging that is done in front of the ADC. This is an Advanced control that normally does not need to be changed.

AUTO - automatic range

Auto Peak (APEak) - automatically peak the range

Auto Peak Lock (APLOCK)- automatically peak lock the range

GROund - ground

NONE - (PSA) turn off auto-ranging without making any changes to the current setting.

M6 - (E4406A) subtracts 6 dB of fixed gain across the range

P0 to P18 - (PSA) adds 0 to 18 dB of fixed gain across the range

P0 to P24 - (E4406A) adds 0 to 24 dB of fixed gain across the range

Factory Preset: AUTO

Remarks: To use this command for E4406A, the appropriate mode should be selected with INSTRUMENT:SElect.

For PSA you must be in the Basic, cdmaOne, cdma2000, 1xEV-DO, W-CDMA, GSM, EDGE, NADC, or PDC mode to use this command. Use INSTRUMENT:SElect to set the mode.

Waveform - Query Aperture Setting

`[:SENSe] :WAVeform:APERTure?`

Returns the waveform sample period (aperture) based on current resolution bandwidth, filter type, and decimation factor. Sample rate is the reciprocal of period.

Remarks: To use this command for E4406A, the appropriate mode should be selected with `INSTRument:SElect`.

For PSA you must be in the Basic, `cdmaOne`, `cdma2000`, `1xEV-DO`, `W-CDMA`, `GSM`, `EDGE`, `NADC`, or `PDC` mode to use this command. Use `INSTRument:SElect` to set the mode.

Waveform—Number of Averages

`[:SENSe] :WAVeform:AVERAge:COUNT <integer>`

`[:SENSe] :WAVeform:AVERAge:COUNT?`

Set the number of sweeps that will be averaged. After the specified number of sweeps (average counts), the averaging mode (terminal control) setting determines the averaging action.

Factory Preset: 10

Range: 1 to 10,000

Remarks: To use this command for E4406A, the appropriate mode should be selected with `INSTRument:SElect`.

For PSA you must be in the Basic, `cdmaOne`, `cdma2000`, `1xEV-DO`, `W-CDMA`, `GSM`, `EDGE`, `NADC`, or `PDC` mode to use this command. Use `INSTRument:SElect` to set the mode.

Waveform—Averaging State

`[:SENSe] :WAVeform:AVERAge [:STATe] OFF | ON | 0 | 1`

`[:SENSe] :WAVeform:AVERAge [:STATe] ?`

Turn averaging on or off.

Factory Preset: OFF

Remarks: To use this command for E4406A, the appropriate mode should be selected with `INSTRument:SElect`.

For PSA you must be in the Basic, `cdmaOne`, `cdma2000`, `1xEV-DO`, `W-CDMA`, `GSM`, `EDGE`, `NADC`, or `PDC` mode to use this command. Use `INSTRument:SElect` to

set the mode.

Waveform—Averaging Mode

```
[ :SENSE ] :WAVEform:AVERAge:TCONtrol EXPOnential | REPeat
```

```
[ :SENSE ] :WAVEform:AVERAge:TCONtrol?
```

Select the type of termination control used for the averaging function. This determines the averaging action after the specified number of ‘sweeps’ (average count) is reached.

EXPOnential - Each successive data acquisition after the average count is reached, is exponentially weighted and combined with the existing average.

REPeat - After reaching the average count, the averaging is reset and a new average is started.

Factory Preset: EXPOnential

Remarks: To use this command for E4406A, the appropriate mode should be selected with INSTRUMENT:SElect.

For PSA you must be in the Basic, cdmaOne, cdma2000, 1xEV-DO, W-CDMA, GSM, EDGE, NADC, or PDC mode to use this command. Use INSTRUMENT:SElect to set the mode.

Waveform—Averaging Type

```
[ :SENSE ] :WAVEform:AVERAge:TYPE
```

```
LOG | MAXimum | MINimum | RMS | SCALar
```

```
[ :SENSE ] :WAVEform:AVERAge:TYPE?
```

Select the type of averaging.

LOG - The log of the power is averaged. (This is also known as video averaging.)

MAXimum - The maximum values are retained.

MINimum - The minimum values are retained.

RMS - The power is averaged, providing the rms of the voltage.

Factory Preset: RMS

Remarks: To use this command for E4406A, the appropriate mode should be selected with INSTRUMENT:SElect.

For PSA you must be in the Basic, cdmaOne, cdma2000, 1xEV-DO, W-CDMA, GSM, EDGE, NADC, or PDC

mode to use this command. Use INSTRUMENT:SElect to set the mode.

Waveform—Resolution BW

```
[ :SENSe ] :WAVeform:BANDwidth|BWIDth[:RESolution] <freq>
```

```
[ :SENSe ] :WAVeform:BANDwidth|BWIDth[:RESolution] ?
```

Set the resolution bandwidth. This value is ignored if the function is auto-coupled.

Factory Preset: 100.0 kHz for NADC, PDC, cdma2000, W-CDMA, Basic, Service (E4406A)
500.0 kHz for GSM
2.0 MHz for cdmaOne

Range: 1.0 kHz to 8.0 MHz when
[:SENSe]:WAVeform:BANDwidth|BWIDth
[:RESolution]:TYPE GAUSSian

1.0 kHz to 10.0 MHz when
[:SENSe]:WAVeform:BANDwidth|BWIDth
[:RESolution]:TYPE FLATtop

Remarks: To use this command for E4406A, the appropriate mode should be selected with INSTRUMENT:SElect.

For PSA you must be in the Basic, cdmaOne, cdma2000, 1xEV-DO, W-CDMA, GSM, EDGE, NADC, or PDC mode to use this command. Use INSTRUMENT:SElect to set the mode.

Bandwidths > 6.7 MHz will require a slight increase in measurement time.

Waveform - Query Actual Resolution Bandwidth

```
[ :SENSe ] :WAVeform:BANDwidth:RESolution] :ACTual ?
```

Due to memory constraints the actual resolution bandwidth value may vary from the value entered by the user. For most applications the resulting difference in value is inconsequential but for some it is necessary to know the actual value; this query retrieves the actual resolution bandwidth value.

Remarks: To use this command for E4406A, the appropriate mode should be selected with INSTRUMENT:SElect.

For PSA you must be in the Basic, cdmaOne, cdma2000, 1xEV-DO, W-CDMA, GSM, EDGE, NADC, or PDC mode to use this command. Use INSTRUMENT:SElect to

set the mode.

History: E4406A:
Version A.05.00 or later

Waveform—Resolution BW Filter Type

```
[ :SENSE ] :WAVEform:BANDwidth | BWIDth [ :RESolution ] :TYPE  
FLATtop | GAUSSian
```

```
[ :SENSE ] :WAVEform:BANDwidth | BWIDth [ :RESolution ] :TYPE?
```

Select the type of Resolution BW filter that is used. This is an Advanced control that normally does not need to be changed.

FLATtop - a filter with a flat amplitude response, which provides the best amplitude accuracy.

GAUSSian - a filter with Gaussian characteristics, which provides the best pulse response.

Factory Preset: GAUSSian

Remarks: To use this command for E4406A, the appropriate mode should be selected with INSTRUMENT:SElect.

For PSA you must be in the Basic, cdmaOne, cdma2000, 1xEV-DO, W-CDMA, GSM, EDGE, NADC, or PDC mode to use this command. Use INSTRUMENT:SElect to set the mode.

Waveform—Decimation of Waveform Display

```
[ :SENSE ] :WAVEform:DECimate [ :FACTor ] <integer>
```

```
[ :SENSE ] :WAVEform:DECimate [ :FACTor ] ?
```

Set the amount of data decimation done on the IQ data stream. For example, if 4 is selected, three out of every four data points will be thrown away. So every 4th data point will be kept.

Factory Preset: 1

Range: 1 to 4

Remarks: To use this command for E4406A, the appropriate mode should be selected with INSTRUMENT:SElect.

For PSA you must be in the Basic, cdmaOne, cdma2000, 1xEV-DO, W-CDMA, GSM, EDGE, NADC, or PDC mode to use this command. Use INSTRUMENT:SElect to set the mode.

Waveform—Control Decimation of Waveform Display

```
[ :SENSe ] :WAVEform:DECimate:STATe OFF | ON | 0 | 1  
[ :SENSe ] :WAVEform:DECimate:STATe?
```

Set the amount of data decimation done by the hardware in order to decrease the number of acquired points in a long capture time. This is the amount of data that the measurement ignores.

Factory Preset: OFF

Remarks: To use this command for E4406A, the appropriate mode should be selected with INSTRUMENT:SElect.

For PSA you must be in the Basic, cdmaOne, cdma2000, 1xEV-DO, W-CDMA, GSM, EDGE, NADC, or PDC mode to use this command. Use INSTRUMENT:SElect to set the mode.

Waveform—Sweep (Acquisition) Time

```
[ :SENSe ] :WAVEform:SWEep:TIME <time>  
[ :SENSe ] :WAVEform:SWEep:TIME?
```

Set the measurement acquisition time. It is used to specify the length of the time capture record.

Factory Preset: 2.0 ms

10.0 ms, for NADC, PDC

15.0 ms, for iDEN mode (E4406A)

Range: 1 μ s to 100 s

Default Unit: seconds

Remarks: To use this command for E4406A, the appropriate mode should be selected with INSTRUMENT:SElect.

For PSA you must be in the Basic, cdmaOne, cdma2000, 1xEV-DO, W-CDMA, GSM, EDGE, NADC, or PDC mode to use this command. Use INSTRUMENT:SElect to set the mode.

Waveform—Trigger Source

```
[ :SENSe ] :WAVEform:TRIGger:SOURce EXTernal [1] |  
EXTernal2 | FRAME | IF | IMMEDIATE | LINE | RFBurst  
[ :SENSe ] :WAVEform:TRIGger:SOURce?
```

Select the trigger source used to control the data acquisitions.

EXTErnal 1 - front panel external trigger input

EXTErnal 2 - rear panel external trigger input

FRAME - internal frame timer from front panel input

IF - internal IF envelope (video) trigger

IMMEdiate - the next data acquisition is immediately taken (also called free run)

LINE - internal line trigger

RFBurst - wideband RF burst envelope trigger that has automatic level control for periodic burst signals

Factory Preset: IMMEdiate (free run), for Basic, cdmaOne, NADC, PDC mode

RFBurst, for GSM, iDEN (E4406A) modes

Remarks: To use this command for E4406A, the appropriate mode should be selected with INSTRument:SElect.

For PSA you must be in the Basic, cdmaOne, cdma2000, 1xEV-DO, W-CDMA, GSM, EDGE, NADC, or PDC mode to use this command. Use INSTRument:SElect to set the mode.

TRIGger Subsystem

The Trigger Subsystem is used to set the controls and parameters associated with triggering the data acquisitions. Other trigger-related commands are found in the INITiate and ABORt subsystems.

The trigger parameters are global within a selected Mode. The commands in the TRIGger subsystem set up the way the triggers function, but selection of the trigger source is made from each measurement. There is a separate trigger source command in the SENSE:<meas> subsystem for each measurement. The equivalent front panel keys for the parameters described in the following commands, can be found under the **Mode Setup, Trigger** key.

Automatic Trigger Control

```
:TRIGger[:SEquence]:AUTO:STATE OFF|ON|0|1
```

```
:TRIGger[:SEquence]:AUTO:STATE?
```

Turns the automatic trigger function on and off. This function causes a trigger to occur if the designated time has elapsed and no trigger occurred. It can be used with unpredictable trigger sources, like external or burst, to make sure a measurement is initiated even if a trigger doesn't occur. Use TRIGger[:SEquence]:AUTO[:TIME] to set the time limit.

Factory Preset

and *RST Off for cdma2000, W-CDMA, NADC, PDC, 1xEV-DO

Front Panel

Access **Mode Setup, Trigger, Auto Trig**

Automatic Trigger Time

```
:TRIGger[:SEquence]:AUTO[:TIME] <time>
```

```
:TRIGger[:SEquence]:AUTO[:TIME]?
```

After the measurement is activated the instrument will take a data acquisition immediately upon receiving a signal from the selected trigger source. If no trigger signal is received by the end of the time specified in this command, a data acquisition is taken anyway. TRIGger[:SEquence]:AUTO:STATE must be on.

Factory Preset: 100.0 ms

Range: 1.0 ms to 1000.0 s

0.0 to 1000.0 s for cdma2000, W-CDMA, 1xEV-DO

Default Unit: seconds
Front Panel
Access **Mode Setup, Trigger, Auto Trig**

External Trigger Delay

```
:TRIGger[:SEquence]:EXTernal[1]|2:DElay <time>
:TRIGger[:SEquence]:EXTernal[1]|2:DElay?
```

Set the trigger delay when using an external trigger. Set the trigger value to zero (0) seconds to turn off the delay.

EXT or EXT1 is the front panel trigger input.

EXT2 is the rear panel trigger input.

Factory Preset: 0.0 s
Range: -100.0 ms to 500.0 ms
Default Unit: seconds
Front Panel
Access: **Mode Setup, Trigger, Ext Rear (or Ext Front), Delay**

External Trigger Level

```
:TRIGger[:SEquence]:EXTernal[1]|2:LEvel <voltage>
:TRIGger[:SEquence]:EXTernal[1]|2:LEvel?
```

Set the trigger level when using an external trigger input.

EXT or EXT1 is the front panel trigger input

EXT2 is the rear panel trigger input

Factory Preset: 2.0 V
Range: -5.0 to +5.0 V
Default Unit: volts
Front Panel
Access: **Mode Setup, Trigger, Ext Rear (or Ext Front), Level**

External Trigger Slope

```
:TRIGger[:SEquence]:EXTernal[1]|2:SLOpe NEGative|POSitive
```

:TRIGger [:SEQuence] :EXTeRnal [1] | 2 :SLOPe?

Sets the trigger slope of an external trigger input to either NEGative or POSitive.

EXT or EXT1 is the front panel trigger input.

EXT2 is the rear panel trigger input.

Factory Preset: Positive

Front Panel

Access: **Mode Setup, Trigger, Ext Rear (or Ext Front), Slope**

Frame Trigger Adjust

:TRIGger [:SEQuence] :FRAMe:ADJust <time>

Lets you advance the phase of the frame trigger by the specified amount. It does not change the period of the trigger waveform. If the command is sent multiple times, it advances the phase of the frame trigger more each time it is sent.

Factory Preset: 0.0 s

Range: 0.0 to 10.0 s

Default Unit: seconds

Front Panel

Access: None

Frame Trigger Period

:TRIGger [:SEQuence] :FRAMe:PERiod <time>

:TRIGger [:SEQuence] :FRAMe:PERiod?

Set the frame period that you want when using the external frame timer trigger. If the traffic rate is changed, the value of the frame period is initialized to the preset value.

Factory Preset: 250.0 μ s for Basic, cdmaOne

4.615383 ms, for GSM

26.666667 ms for cdma2000 and 1xEV-DO

10.0 ms (1 radio frame) for W-CDMA

90.0 ms for iDEN (E4406A)

20.0 ms with rate=full for NADC, PDC

40.0 ms with rate=half for NADC, PDC

Range: 0.0 ms to 559.0 ms for Basic, cdmaOne, GSM,

cdma2000, W-CDMA, 1xEV-DO

1.0 ms to 559.0 ms for iDEN (E4406A), NADC, PDC

Default Unit: seconds

Front Panel

Access: **Mode Setup, Trigger, Frame Timer, Period**

Frame Trigger Sync Source

:TRIGger[:SEQuence]:FRAMe:SYNC EXTFront | EXTReAr | OFF

:TRIGger[:SEQuence]:FRAMe:SYNC?

Selects the input port location for the external frame trigger that you are using.

Factory Preset: Off

Remarks: You must be in the Basic, cdmaOne, EDGE (w/GSM), GSM, iDEN (E4406A), NADC, PDC, Service mode to use this command. Use INSTRument:SElect to set the mode.

Front Panel

Access: **Mode Setup, Trigger, Frame Timer, Sync Source**

History Changed firmware revision A.05.00.

Frame Trigger Synchronization Offset

:TRIGger[:SEQuence]:FRAMe:SYNC:OFFSet <time>

:TRIGger[:SEQuence]:FRAMe:SYNC:OFFSet?

Lets you adjust the frame triggering with respect to the external trigger input that you are using.

Factory Preset: 0.0 s

Range: 0.0 to 10.0 s

Default Unit: seconds

Remarks: You must be in the Basic, cdmaOne, GSM, EDGE, iDEN (E4406A), NADC, PDC, Service mode to use this command. Use INSTRument:SElect to set the mode.

History: Revision A.03.27 or later

Front Panel

Access: **Mode Setup, Trigger, Frame Timer, Offset**

Trigger Holdoff

`:TRIGger[:SEquence]:HOLDoff <time>`

`:TRIGger[:SEquence]:HOLDoff?`

Set a value of the holdoff time between triggers. After a trigger, another trigger will not be allowed until the holdoff time expires. This parameter affects all trigger sources.

Factory Preset: 0.0 s

20.0 ms for iDEN (E4406A)

10.0 ms for NADC or PDC

Range: 0.0 to 500.0 ms

Default Unit: seconds

Front Panel

Access: **Mode Setup, Trigger, Trigger Holdoff**

Video (IF) Trigger Delay

`:TRIGger[:SEquence]:IF:DElay <time>`

`:TRIGger[:SEquence]:IF:DElay?`

Set a value of the trigger delay of the IF (video) trigger (signal after the resolution BW filter).

Factory Preset: 0.0 s

Range: -100.0 ms to 500.0 ms

Default Unit: seconds

Front Panel

Access: **Mode Setup, Trigger, Video (IF Envlp), Delay**

Video (IF) Trigger Level

`:TRIGger[:SEquence]:IF:LEvel <ampl>`

`:TRIGger[:SEquence]:IF:LEvel?`

Set the trigger level when using the IF (video) trigger.

Factory Preset: -6.0 dBm for cdmaOne, GSM, EDGE, Basic, Service (E4406A), cdma2000, W-CDMA, 1xEV-DO

–20.0 dBm for iDEN (E4406A)
 –30.0 dBm for NADC, PDC
 Range: –200.0 to 50.0 dBm
 Default Unit: dBm
 Front Panel
 Access: **Mode Setup, Trigger, Video (IF Envlp), Level**

Video (IF) Trigger Slope

```
:TRIGger[:SEquence]:IF:SLOPe NEGative|POSitive
:TRIGger[:SEquence]:IF:SLOPe?
```

Sets the trigger slope when using the IF (video) trigger, to either NEGative or POSitive.

Factory Preset: Positive

Front Panel

Access: **Mode Setup, Trigger, Video (IF Envlp), Slope**

RF Burst Trigger Delay

```
:TRIGger[:SEquence]:RFBurst:DElay <time>
:TRIGger[:SEquence]:RFBurst:DElay?
```

Set the trigger delay when using the RF burst (wideband) trigger.

Factory Preset: 0.0 μ s

Range: –100.0 ms to 500.0 ms

Default Unit: seconds

Front Panel

Access: **Mode Setup, Trigger, RF Burst, Delay**

RF Burst Trigger Level

```
:TRIGger[:SEquence]:RFBurst:LEvel <rel_power>
:TRIGger[:SEquence]:RFBurst:LEvel?
```

Set the trigger level when using the RF Burst (wideband) Trigger. The value is relative to the peak of the signal. RF Burst is also known as RF Envelope.

Factory Preset: -6.0 dB

Range: -25.0 to 0.0 dB
-200.0 to 0.0 dB for NADC, PDC

Default Unit: dB

Front Panel

Access: **Mode Setup, Trigger, RF Burst, Peak Level**

RF Burst Trigger Slope

`:TRIGger[:SEQuence]:RFBurst:SLOPe NEGative|POSitive`

`:TRIGger[:SEQuence]:RFBurst:SLOPe?`

Set the trigger slope when using the RF Burst (wideband) Trigger.

Factory Preset: Positive

Remarks: You must be in the cdmaOne, cdma2000, W-CDMA mode to use this command. Use `:INSTrument:SElect` to set the mode.

Front Panel

Access: **Mode Setup, Trigger, RF Burst, Slope**

Numerics

- 1xEV-DO
 - mode setup
 - demod RF carrier, 77
 - input, 72
 - radio, 71
 - trigger, 75
 - radio, 71
 - terminal modulation accuracy, 313
- 1xEV-DO measurement, 401, 405, 464
- 1xEV-DO system
 - RF characteristics, 30
 - design elements, 31
 - forward link, 30
 - forwardlink channel TDM structure, 31
 - frame structure, 31
 - high rate packet data, 30
 - high speed packet data communications, 30
 - network rate, 30
 - reverse link coding, 32
 - standard documents, 34
 - what is it?, 30

A

- ACK
 - acknowledge channel, 33
- ACK channel definition
 - terminal code domain measurement, 516
 - terminal modulation accuracy measurement, 521
- ACK channel power gain
 - terminal modulation accuracy (rho), 312
- ACP
 - offset sideband choice, 477
 - testing, 477
- ACP or spurious emissions
 - marker menu
 - marker selection, 164
 - reference channel integration bandwidth method, 150
- ACPR
 - testing choices, 477
- ADC Dither key
 - spectrum measurement, 246
- ADC Range key
 - spectrum measurement, 245
- ADC dithering
 - SPECTrum, 502
 - WAVEform, 528
- ADC filter
 - WAVEform, 528

- ADC range
 - QPSK EVM, 422
 - SPECTrum, 503
 - WAVEform, 529
 - code domain power, 411
 - manual control, 230
 - modulation accuracy (rho), 458
 - terminal code domain measurement, 517
 - terminal modulation accuracy measurement, 522
 - ADC ranging function
 - automatic control, 175, 187, 203, 220, 230, 257
 - automatic control to peak, 175, 187, 204, 220
 - automatic lock to peak, 175, 187, 204, 220, 230
 - automatic peak control, 230, 257
 - automatic peak lock, 257
 - manual control, 175, 187, 204, 220, 257
 - ASCII data format, 332
 - Active Set Threshold level
 - terminal modulation accuracy measurement, 524
 - Advanced menu
 - spectrum, 244
 - waveform, 256
- ## C
- CCDF measurement, 369
 - CDMA measurement, 359, 411, 417, 458
 - CDP
 - Walsh code number, 275
 - Walsh code order, 276
 - active set threshold, 272
 - computation type, 275
 - data bit format threshold, 273
 - data channel type, 275
 - measurement channel type, 272
 - sweep offset, 273
 - sweep time, 274
 - CDPower
 - Phase compensation by pilot, 414
 - chip rate, 413
 - data capture time, 413
 - selecting spectrum type, 415
 - trigger source, 416
 - view of data, 317
 - CHPower
 - number of points, 418
 - sweep time, 419
 - trigger source, 420

- CONFigure command use, 339
- CONFigure commands, 341
- Choose Option key, 117

D

- DRC
 - data request channel, 33
- DRC channel definition
 - terminal code domain measurement, 517
 - terminal modulation accuracy measurement, 522
- DRC channel power gain
 - terminal modulation accuracy (rho), 313
- Data Packing
 - spectrum measurement, 245, 257
- Decimation
 - spectrum measurement, 246

E

- EVM
 - amplitude Y scale
 - reference position, 194
 - reference value, 193
 - scale coupling, 194
 - scale per division, 193
- EVM graph
 - amplitude Y scale, 223
- EVM or magnitude error graph
 - amplitude Y scale, 210
 - reference position, 233
 - reference value, 233
 - scale per division, 233

F

- FETCh command use, 339
- FETCh commands, 341
- FFT
 - SPECTrum, 510, 511, 512
- FFT Length key, 245
- FFT Size menu, 245
- FFT Window key, 244
- FFT bandwidth, SPECTrum, 506, 507, 508
- FFT window
 - Blackman filter, 168
 - Blackman-Harris filter, 168
 - Gaussian filter with alpha 3.5, 168
 - Hamming filter, 168
 - Kaiser-Bessel 110 dB filter, 168
 - Kaiser-Bessel 90 dB filter, 168
 - flat top filter, 168
 - occupied bandwidth, 436

- uniform filter, 168
- FT window
 - Hanning filter, 168
- G**
- GSM measurement, 443
- I**
- I Origin key, 251
- I and Q waveform view
 - I or Q waveform window, 250
- I long code mask
 - terminal code domain measurement, 520
 - terminal modulation accuracy measurement, 526
- I or Q waveform window
 - amplitude Y scale, 250
 - reference position, 251
 - reference value, 251
 - scale coupling, 251
 - scale per division, 251
 - span X scale, 250
 - reference position, 250, 260
 - reference value, 250, 260
 - scale coupling, 250, 260
 - scale per division, 250, 260
- I origin
 - I/Q polar window, 262
- I waveform window
 - amplitude Y scale, 261
 - reference position, 262
 - scale coupling, 262
 - scale per division, 261
- I/Q Polar view
 - waveform measurement, 262
- I/Q Scale/Div key, 251
- I/Q data results, 398, 408
- I/Q error (quad view)
 - phase error graph
 - amplitude Y scale, 224
- I/Q error graphs
 - EVM
 - amplitude Y scale, 193
 - EVM or magnitude error graph
 - amplitude Y scale, 233
 - scale coupling, 233
 - magnitude error
 - amplitude Y scale, 193
 - phase error
 - amplitude Y scale, 194
 - span X scale, 193, 210, 223, 232
 - reference position, 193, 233
 - reference value, 193, 233
 - scale coupling, 193, 233
 - scale per division, 193, 232
 - I/Q polar view
 - I/Q polar window, 251, 262
 - I/Q polar window
 - I origin, 262
 - I/Q scale per division, 262
 - Q origin, 262
 - amplitude Y scale, 251
 - I/Q scale per division, 251
 - Q Origin, 251
 - span X scale, 251
 - I Origin, 251
 - I/Q scale per division
 - I/Q polar window, 262
 - I/Q waveform graph
 - amplitude Y scale, 211
 - I/Q waveform view
 - I/Q waveform window, 261
 - I/Q waveform window, 260
 - amplitude Y scale, 261
 - reference position, 262
 - reference value, 261
 - scale coupling, 262
 - scale per division, 261
- IF Flatness
 - advanced spectrum feature, 246
- IF trigger delay, 540
- IF trigger level, 540
- IF trigger slope, 541
- IQ port selection, 427
- Install Now key, 117
- Internal RF Preamplifier, 73
- L**
- Length Ctrl key, 245
- Length key, 245
- M**
- MAC
 - medium access control, 32
- MEASure command use, 339
- MEASure commands, 340
- Min Pts in RBW key, 245
- O**
- OBW
 - limit testing, 302
 - trigger source, 437
- OBW averaging, 434
- P**
- PDC
 - trigger source, 437
- PDC measurement, 367, 434
- PN offset
 - CDPower, 414
- modulation accuracy (rho), 461
- PSA series versus VSA
 - (programming compatibility), 270
- PVT
 - view of data, 318, 319
- PVT limits display, 318
- PVTime
 - bandwidth, 446, 447
- Phase compensation by pilot
 - CDPower, 414
- Pilot channel definition
 - terminal code domain measurement, 517
 - terminal modulation accuracy measurement, 522
- Pre-ADC BPF key
 - spectrum measurement, 244
- Pre-FFT BW key, 244
- Pre-FFT Fltr key, 244
- Preamplifier
 - Setting the internal preamplifier, 73
- Q**
- Q Origin key, 251
- Q long code mask
 - terminal code domain measurement, 520
 - terminal modulation accuracy measurement, 526
- Q origin
 - I/Q Polar window, 262
 - I/Q polar window, 262
- Q waveform window
 - amplitude Y scale, 261
 - reference position, 262
 - reference value, 261
 - scale coupling, 262
 - scale per division, 261
- QPSK EVM
 - ADC range, 422
 - RF carrier mode, 425
 - averaging, 423, 424
 - chip rate, 424
 - display menu, 232
 - length, 425
 - measurement offset, 425
 - measurement setup, 228
 - phase and frequency errors, 226
 - quadrature phase shift keying
 - modulation, 226
 - trigger source, 426
 - view/trace menu, 230
- QPSK EVM phase trajectory, 226
- QPSK error vector magnitude
 - measurement, 361, 422

- QPSK error vector measurement
 - See also EVMQpsk
- R**
- RA
 - reverse activity, 32
- READ command use, 339
- READ commands, 342
- RF carrier mode
 - QPSK EVM, 425
- RF characteristics
 - spread rate, 30
- RF input port gain setting when pre-amplifier is on, 438
- RF input port power gain, 438
- RF input, selection, 427
- RHO
 - active data channel, 458
 - frequency error limit test, 306, 307, 313
 - limit testing, 306
 - measurement channel type, 309
 - measurement data type, 309
 - spectrum type, 462
 - view of data, 319
- RMS EVM limit
 - W-CDMA (3GPP) (BTS), 308
 - cdma2000 (BTS), 308
 - modulation accuracy (rho) (BTS), 308
 - terminal modulation accuracy (rho), 315
- RMS of trace data, 281, 288
- RPC
 - reverse power control, 32
- RRI
 - reverse rate indication, 33
- RRI limit
 - 1xEV-DO, 315
 - terminal modulation accuracy (rho), 315
- Res BW key
 - spectrum measurement, 244
 - waveform measurement, 256
- S**
- SPECTrum
 - ADC range, 503
 - FFT length, 510
 - FFT resolution BW, 511
 - FFT window, 512
 - FFT window delay, 511
 - acquisition packing, 502
 - data decimation, 509
 - frequency span, 513
 - sweep time, 513, 514
 - trigger source, 514
- Span key
 - spectrum measurement, 244
- Spectrum (Frequency Domain) key, 241
- Sweep Time key, 256
- T**
- TCDP
 - Walsh code length, 279
 - Walsh code number, 279
 - Walsh code order, 279
 - active set threshold, 277
 - active set threshold mode, 277
 - computation type, 278
 - decode axis, 277
 - sweep time, 278
- TCDPower
 - view of data, 322
- Terminal code domain measurement, 516
- Terminal modulation accuracy measurement, 521
- U**
- Uninstall Now, 118, 119
- V**
- VSA versus PSA series (programming compatibility), 270
- W**
- WAVEform
 - ADC dithering, 528
 - ADC filter, 528
 - ADC range, 529
 - acquisition packing, 528
 - data decimation, 533, 534
 - sweep time, 534
 - trigger source, 534
- W-CDMA
 - trigger source, 463
- W-CDMA (3GPP)
 - averaging, 423, 424
 - offset frequencies, 469, 485, 486, 497
 - offset frequencies auto mode, 470, 471, 487
 - spectrum emission mask measurement, 477, 479, 480, 482, 484, 491, 492, 494, 495, 496, 497
 - trigger source, 426, 500
- W-CDMA (3GPP) measurement, 343, 361, 364, 367, 369, 376, 392, 422, 428, 434, 441, 464
- W-CDMA (Trial & ARIB)
 - averaging, 423, 424
 - trigger source, 426
- W-CDMA (Trial & ARIB) measurement, 343, 361, 369, 376, 422, 441
- Waveform (Time Domain) key, 254
- Window Length key, 245
- Z**
- access network
 - base station, 30
- access network (BTS), 30
- access terminal
 - mobile station, 30
- acquisition packing
 - WAVEform, 528
- active code channel
 - auto detection, 186, 218
 - combined detection, 186, 218
 - terminal code domain measurement, 516
 - terminal modulation accuracy measurement, 521
 - use predefined active channel, 186, 218
- active code domain power tolerance
 - terminal modulation accuracy (rho), 312
- active data channel
 - RHO, 458
 - code domain power, 411
- active license key, 118
- how to locate, 118
- active set th (threshold) advanced menu, 175
- active set threshold
 - CDP, 272
 - TCDP, 277
 - modulation accuracy (rho), 305
 - terminal modulation accuracy (rho), 311
- active set threshold mode
 - TCDP, 277
 - modulation accuracy (rho), 305
 - terminal modulation accuracy (rho), 311
- advanced menu
 - ADC dither, 258
 - ADC ranging function, 175, 187, 203, 220, 229, 257
 - EVM result I/Q offset, 203, 219
 - FFT window, 168
 - active set th (threshold), 175
 - active set threshold, 186, 204

- burst slope detection interval, 145
- burst slope threshold level, 145
- chip rate, 175, 186, 203, 220, 229
- decimation, 258
- integration bandwidth, 138
- multi channel estimator, 203, 220
- number of data points, 133
- overall rho including preamble chips, 203
- phase compensation, 175
- pre-ADC bandpass filter, 257
- resolution bandwidth, 133, 145
- resolution bandwidth filter, 145, 257
- sweep time, 133
- time reference offset, 145
- trigger source, 133
- amplitude
 - input range, 439
 - maximizing input signal, 440
- amplitude Y scale
 - reference position, 133, 139, 148, 163, 169, 210, 211, 212, 224
 - reference value, 133, 139, 148, 163, 169, 210, 211, 212, 224
 - scale coupling, 133, 139, 148, 163, 169, 210, 211, 212, 224
 - scale per division, 133, 139, 148, 163, 169, 210, 211, 212, 223, 224
- applications
 - currently available, 336
- applications, selecting, 336, 337
- attenuation
 - setting, 438
- average count
 - intermodulation, 428
 - terminal modulation accuracy measurement, 524
- averaging
 - CHPower, 417, 434, 435
 - OBW, 434
 - QPSK EVM, 423, 424
 - SPECTrum, 504, 505
 - WAVEform, 530, 531
 - modulation accuracy (rho), 459, 460
 - power vs. time, 443, 444
 - traces, 436
 - transmit band spurs, 530
- averaging count
 - spectrum emission mask, 464
- averaging state
 - intermodulation, 428
 - power vs. time, 443
 - spectrum emission mask, 464
 - terminal modulation accuracy measurement, 524, 525
- averaging termination control
 - intermodulation, 428
 - terminal modulation accuracy measurement, 524
- averaging type
 - log power averaging (video), 143
 - maximum voltage averaging, 143
 - minimum voltage averaging, 143
 - rms power averaging, 143
 - voltage averaging, 143
- bandwidth
 - PVTime, 446, 447
 - SPECTrum, 508, 509
 - WAVEform, 532, 533
 - occupied bandwidth, 435
 - power vs. time, 445
 - spectrum emission mask, 465
- base frequencies delta
 - intermodulation, 430
- base frequency auto search
 - intermodulation, 430
- base frequency selection
 - delta frequency (f1-f0), 138
 - lower frequency (f0), 138
 - upper frequency (f1), 138
- base lower frequency
 - intermodulation, 431
- base station testing, 457
- base transmit station
 - loss correction, 421
- base upper frequency
 - intermodulation, 431
- binary data order, 332
- burst trigger
 - level, 541
- byte order of data, 332
- carrier selection, 457
- cdma2000
 - averaging, 423, 424
 - offset frequencies, 469, 485, 486, 497
 - offset frequencies auto mode, 470, 471, 487
 - spectrum emission mask measurement, 477, 479, 480, 482, 484, 491, 492, 494, 495, 496, 497
 - trigger source, 426, 463, 500
- cdma2000 measurement, 361, 364, 367, 369, 376, 392, 422, 428, 434, 441, 464
- cdmaOne
 - trigger source, 463
- cdmaOne measurement, 343, 376
- changing
 - instrument settings, 411
- channel power
 - advanced menu, 130
 - amplitude Y scale, 133
 - changing display, 133
 - channel bandwidth, 130
 - measurement setup, 132
 - power spectral density, 130
 - time record length, 130
- channel power measurement
 - See also CHPower
- channel power measurement, 359, 417
- channel type
 - data channel, 174
 - medium access control channel, 174
 - pilot channel, 174
- chip power graph
 - amplitude Y scale, 178, 212
 - reference position, 179
 - reference value, 178
 - scale coupling, 179
 - scale per division, 178
- span X scale, 178
 - reference value, 178
 - scale coupling, 178
 - scale per division, 178
- chip rate
 - CDPower, 413
 - QPSK EVM, 424
 - modulation accuracy (rho), 460
 - terminal code domain measurement, 519
 - terminal modulation accuracy measurement, 525
- code domain
 - I/Q error with quad view, 182
 - I/Q gain imbalance, 170, 181
 - I/Q modulation impairments, 170, 181
 - I/Q polar and power graph, 171
 - I/Q quadrature error, 170, 181
 - OVSF channels, 181
 - amplitude Y scale, 190
 - code domain with quad view, 182
 - demodulated bit stream, 182
 - display, 190
 - chip dots, 190

- in-channel characteristics, 170, 181
- marker function, 195
 - all markers off, 195
 - delta reading, 195
- despread marker position, 195
- marker measurement
 - function, 195
 - marker selection, 195
 - normal reading, 195
 - off, 195
 - shape selection, 195
 - trace with marker, 195
- marker menu, 179
- measure control, 184
- measure setup, 184
 - Walsh code number, 185
 - advanced menu, 186
 - measurement interval, 185
 - measurement offset, 185
- measurement control, 173
 - continuous, 173
 - measure, 173
 - single, 173
- measurement setup, 173
- next window, 187
- pilot channel, 170, 181
- power composite view, 170, 181
- power graph & metrics, 171, 182
- span X scale, 190
- spread channels, 170
- traffic channel, 170, 181
- view/trace, 187
 - I/Q error graphs, 193
 - IQ error (quad view), 187
 - code domain with quad view, 188
 - demodulated bit stream view, 189
 - demodulated bits, 191
 - power graph & metrics, 187
 - width of channel, 170, 181
 - zoom, 187
- code domain error limit
 - terminal modulation accuracy (rho), 312
- code domain measurement
 - display menu, 177
 - print setup, 194
 - using print function, 194
 - view/trace menu, 176
- code domain power
 - ADC range, 411
 - active data channel, 411
- code domain power graph
 - amplitude Y scale, 178, 191
 - reference value, 178, 192
 - scale per division, 178, 192
 - display, 190
 - code order, 190
 - consolidated marker, 191
 - span X scale, 177
 - reference value, 177, 178
 - scale per division, 177
- code domain power measurement, 343, 411
 - See also CDPower
- code, programming
 - compatibility across PSA modes, 267, 269
 - compatibility, PSA series versus VSA, 270
- commands
 - CONFigure, 341
 - FETCh, 341
 - MEASure, 340
 - PSA series versus VSA
 - compatibility, 270
 - READ, 342
 - compatibility across PSA modes, 267, 269
 - compatibility, programming
 - PSA series versus VSA, 270
 - across PSA modes, 267
 - continuous vs. single
 - measurement mode, 334
 - control measurement commands, 334
 - correction
 - base transmit station loss, 421
 - mobile station loss, 421
 - current measurement, 316
 - curve fit the data, 281, 288
 - data
 - querying, 281, 288
 - data capture time
 - CDPower, 413
 - terminal code domain
 - measurement, 518
 - data channel definition
 - terminal code domain
 - measurement, 516
 - terminal modulation accuracy
 - measurement, 521
 - data channel power gain
 - terminal modulation accuracy (rho), 313
 - data channel type
 - 16QAM, 174
 - 8PSK, 174
 - QPSK, 174
 - data decimation, 509
 - WAVEform, 533, 534
 - data format, 332
- data from measurements, 339
- decimation
 - SPECTrum, 509
- decimation of data
 - WAVEform, 533, 534
- default states, 70
- default values, setting remotely, 341
- deleting an
 - application/personality, 114
- delta markers, 294
- demodulated bits
 - demodulated bits window
 - display, 191
 - display, 191
 - demodulated bits window
 - display
 - first page, 191
 - last page, 191
 - next page, 191
 - previous page, 191
 - scroll down, 191
 - scroll up, 191
- design elements
 - best serving cell, 31
 - data rate request, 31
 - efficient data delivery, 31
 - full power, 31
 - rate control, 31
 - time division multiplexed, 31
- detector
 - peak or average power, 154
- display
 - +45 degrees rotation, 209, 223
 - PVT limits, 318
 - background full vector traces, 223
 - chip interval, 223
 - chip offset, 222
 - code order
 - Hadamard, 191
 - bit reversed, 191
 - spectrum window, 320, 321, 328, 329
 - tiling, 317
 - trace, 323
 - window tile, 317
 - zoom, 318
- display PVT data, 318, 319
- display code domain data, 317
- display commands, 317
- display key
 - burst search threshold line, 147
 - limit mask, 147
- display menu
 - Gaussian line display, 239
 - I/Q chips, 208

- I/Q points, 232
- IM products lines, 139
- MAC channel period, 209
 - absolute peak power levels & frequencies, 163
 - chip descrambled, 209
 - chip dots, 232
 - chip offset, 208
 - data channel period, 209
 - full vector (background), 209
 - integrated power levels, 164
 - limit lines, 163
 - phase reference for I/Q graph, 209
 - pilot channel period, 209
 - reference trace display, 239
 - relative peak power levels & frequencies, 163
 - store reference trace, 239
 - vector and/or constellation selection, 209
- display rho data, 319
- dithering of ADC
 - WAVEform, 528
- dithering the ADC, 502
- external trigger
 - delay, 537
 - level, 537
 - slope, 538
- fail mask condition
 - absolute limit, 158, 160
 - absolute limit AND relative limit, 158, 161
 - absolute limit OR relative limit, 158, 161
 - relative limit, 158, 160
- format, data, 332
- forwardlink channel TDM
 - structure
 - medium access control, 32
 - pilot channel, 32
 - preamble, 32
 - traffic channel, 31
- frame trigger adjustment, 538, 539
- frame trigger period, 538
- frame trigger sync mode, 539
- frequency
 - carrier setting, 457
 - frequency band limits
 - OBW, 302
 - frequency channel, 77
 - center frequency, 77
 - center frequency step, 77
 - frequency error limit test
 - RHO, 306, 307
 - frequency span
 - CHPower, 418
 - SPECTrum, 513
 - spectrum emission mask, 467
 - half slot
 - #1 or #2, 154
 - iDEN
 - trigger source, 437
 - iDEN measurement, 367, 434
 - idle slot
 - #1 or #2, 154
 - initiate measurement, 334, 335
 - input
 - RF input range, 72
 - external attenuator, 73
 - attenuation for BTS tests, 73
 - attenuation for MS tests, 73
 - input attenuator, 73, 74
 - input port, 72
 - 50 MHz reference, 72
 - rf, 72
 - max total power, 73
 - maximum total power, 73
 - input attenuation, 438
 - input port
 - 50 MHz reference, 72
 - IF align, 72
 - input port selection, 427
 - input power
 - maximum, 440
 - range, 439
 - installing measurement
 - personalities, 114
 - instrument configuration, 336
 - integration bandwidth
 - intermodulation, 429
 - intermodulation
 - amplitude Y scale, 138
 - average count, 428
 - averaging state, 428
 - averaging termination control, 428
 - base frequencies delta, 430
 - base frequency auto search, 430
 - base lower frequency, 431
 - base lower signal, 45, 48
 - base upper frequency, 431
 - display menu, 139
 - integration bandwidth, 429
 - intermodulation graph, 45, 48
 - measurement mode, 432
 - measurement reference, 432
 - measurement setup, 137
 - resolution bandwidth, 429
 - resolution bandwidth state, 430
 - span, 432
 - transmit intermodulation
 - products, 135
 - two-tone intermodulation
 - products, 135
 - using markers, 139
 - view/trace menu, 138
 - intermodulation measurement, 364, 428
 - See also IM
 - internal reference selection, 427
 - key flow diagram
 - QPSK EVM, 78
 - acpr, 78
 - channel power, 78
 - code domain, 78
 - intermodulation, 78
 - mode setup / frequency channel, 78
 - modulation accuracy (composite EVM), 78
 - occupied bandwidth, 78
 - power statistic CCDF, 78
 - spectrum (frequency domain), 78
 - spectrum emission mask, 78
 - waveform (time domain), 78
 - length
 - QPSK EVM, 425
 - limit line testing, 281
 - limit testing
 - EVM, 306
 - OBW, 302
 - RHO, 306
 - cdmaOne, 306
 - limits
 - ACK channel gain, 219
 - absolute start level, 160
 - active channel code domain
 - power tolerance, 219
 - composite peak EVM, 202, 218
 - composite rho, 202, 218
 - composite rms EVM, 202, 218
 - data channel gain, 219
 - data rate control channel gain, 219
 - fail mask condition, 160
 - frequency error, 202, 219
 - inactive channel code domain
 - power, 219
 - maximum MAC channel
 - inactive power, 203
 - minimum data channel active
 - power, 203
 - peak code domain error, 219
 - phase error, 203
 - pilot offset, 203, 219
 - relative start level, 160
 - relative stop level, 160

- reverse rate indicator vs pilot
 - power ratio tolerance, 219
 - timing error, 202
- limits absolute stop level, 160
- linear envelope window, 260
- linear envelope window, 260
- linear spectrum window
 - amplitude Y scale, 249
 - reference position, 250
 - reference value, 250
 - scale coupling, 250
 - scale per division, 250
- span, 249
- loading an
 - application/personality, 114
- lower mask
 - level and on/off, 144
- magnitude error
 - amplitude Y scale
 - reference position, 194
 - reference value, 193
 - scale coupling, 194
 - scale per division, 193
- magnitude error graph
 - amplitude Y scale, 223
- major functional keys, 38
- making measurements, 339
- marker menu
 - delta reading, 179, 239
 - despread marker position, 179
 - erase a marker, 179, 239
 - erase all markers, 179, 239
 - function, 239
 - marker function, 179
 - marker selection, 179
 - normal reading, 179, 239
 - select 1 to 4, 239
 - shape selection, 179, 239
 - trace selection, 179, 239
- markers, 290
 - assigning them to traces, 295
 - maximum, 293
 - minimum, 294
 - off, 295
 - trace assignment, 299, 300
 - turn off, 293
 - type, 294
 - valid measurement, 290
 - value, 300
 - value of, 293
 - x-axis location, 299, 300
 - y-axis, 300
- masks
 - power vs. time, 447, 448, 449, 450, 451, 452, 454, 455
- maximum value of trace data, 281, 288
- mean value of trace data, 281, 288
- measure
 - modulation accuracy (composite rho), 199
 - spurious emissions and ACP, 153
 - spurious emissions and adjacent channel power (ACP), 151
- measure control
 - continuous, 185
 - measure, 184
 - single, 185
- measure setup
 - I long code mask, 185, 219
 - I/Q branch signals, 185
 - Q long code mask, 186, 219
 - active code channel, 186, 218
 - advanced menu, 219
 - capture interval, 186
 - limits, 218
 - measure type, 185
 - predefined active channel, 186, 218
 - spectrum, 186, 219
- measure setup Walsh code length, 185
- measure type
 - absolute power, 185
 - relative power, 185
- measurement
 - ACP or spurious emissions mask, 150
 - QPSK EVM, 226
 - QPSK error vector magnitude, 422
 - channel power, 130, 132, 417
 - code domain, 170, 171, 173, 181, 183, 184
 - code domain power, 411
 - intermodulation, 428
 - intermodulation products, 135, 136
 - transmit intermodulation, 135
- markers, 290
- modulation accuracy (composite rho), 197, 201, 214
 - correlated power, 214
 - measure setup, 218
 - modulation quality, 214
 - rho, 214
- modulation accuracy (rho), 458
- occupied BW, 434
- occupied bandwidth, 166, 168
- power statistics CCDF, 236
 - Gaussian distribution curve, 236
- power statistics CCDF
 - measurement, 441
- power vs. time, 443
- query current, 316
- spectrum
 - display, 251
 - spectrum (frequency domain), 502
 - spectrum emission mask, 464
 - spurious emissions and ACP, 464
 - waveform (time domain), 528
- measurement channel type
 - CDP, 272
 - RHO, 309
- measurement control
 - measure, 126
 - pause, 127
 - restart, 126
- measurement data type
 - RHO, 309
- measurement key flow, 78
- measurement mode
 - ACP, 153, 161
 - automatic search mode, 137
 - intermodulation, 432
 - spurious emissions mask, 153
 - transmit IM mode, 137
 - two-tone mode, 137
- measurement modes
 - currently available, 336
 - selecting, 336, 337
- measurement offset
 - QPSK EVM, 425
- measurement offset and interval
 - measurement interval, 154, 228
 - measurement offset, 154, 228
 - pre-defined offset and interval, 154
 - predefined offset and interval, 229
- measurement reference
 - intermodulation, 432
- measurement reference type
 - mean power spectral density reference, 154
 - total power reference, 154
- measurement selection
 - QPSK EVM, 125
 - channel power, 123
 - code domain, 124
 - intermodulation products, 123
 - modulation accuracy (composite rho), 125
 - occupied bandwidth, 124
 - power statistic CCDF, 126
 - power versus time, 124

- spectrum (frequency domain), 126
- spurious emissions and adjacent channel power (ACP), 124
- waveform (time domain), 126
- measurement setup
 - PN offset, 174, 202
 - Walsh code number, 174
 - active data channel, 174, 202
 - advanced menu, 133, 138, 145, 168, 175, 203, 229
 - automatic search for base frequency signal, 138
 - averaging mode, 127
 - exponential, 127
 - normal, 127
 - repeat, 128
 - averaging number, 127
 - averaging type, 128, 143
 - log power average (video), 128
 - maximum voltage average, 128
 - minimum voltage average, 128
 - power average (rms), 128
 - voltage average, 128
 - base frequency selection, 138
 - burst search threshold, 145
 - capture interval, 175
 - channel power span, 132
 - channel type, 174, 201
 - data channel type, 174, 202
 - detector, 154
 - frequency span, 138, 168
 - integration bandwidth, 132
 - limit frequency value, 168
 - limit test, 168
 - limits, 202
 - measurement bandwidth, 238
 - measurement interval, 174, 238
 - measurement mode, 137, 153
 - measurement offset, 174
 - measurement offset and interval, 154, 228
 - measurement reference type, 154
 - measurement type, 173
 - number of counts, 238
 - offsets and limits, 156
 - power reference, 144
 - preamble length, 174, 202
 - reference channel, 155
 - reference signal, 137
 - region and limits, 144
 - resolution bandwidth, 138, 168
 - restore measurement defaults, 127
 - slot type, 143
 - spectrum, 175, 202
 - spectrum segment, 155
 - time reference, 145
 - trigger source, 154
 - measurement type
 - absolute or relative, 173
 - measurements
 - CCDF, 369
 - CONF/FETC/MEAS/READ commands, 339
 - QPSK error vector magnitude, 361
 - channel power, 359
 - code domain power, 343
 - control of, 334
 - getting results, 339
 - intermodulation, 364
 - modulation accuracy, 376
 - modulation accuracy, terminal, 405
 - occupied BW, 367
 - power stat, 369
 - power versus time, 141
 - power vs. time, 371
 - setting default values remotely, 341
 - single/continuous, 334
 - spectrum (frequency domain), 398
 - spectrum emission mask, 392
 - terminal code domain power, 401
 - waveform (time domain), 408
 - measuring I/Q data, 398, 408
 - medium access control
 - reverse activity, 32
 - reverse power control, 32
 - minimum value of trace data, 281, 288
 - missing options, 114
 - mobile station
 - loss correction, 421
 - mobile station testing, 457
 - modulation accuracy (composite rho)
 - correlated power, 197
 - display, 222
 - display menu, 208
 - measurement setup, 201
 - modulation quality, 197
 - rho, 197
 - view/trace, 220
 - view/trace menu, 204
 - modulation accuracy (rho)
 - active set threshold, 305
 - active set threshold mode, 305
 - phase error limit, 307
 - pilot time offset limit, 308
 - rho result I/Q offset, 305
 - time offset limit, 308
 - modulation accuracy (rho) (BTS)
 - RMS EVM limit, 308
 - peak EVM limit, 307
 - rho limit, 308
 - modulation accuracy (rho)
 - measurement, 458
 - See also RHO
 - modulation accuracy
 - measurement, 376
 - multi carrier estimator
 - modulation accuracy (rho), 461
 - normal marker, 294
 - occupied BW measurement, 367, 434
 - See also OBW
 - occupied bandwidth
 - 99.0% bandwidth, 166
 - FFT window, 436
 - amplitude Y scale, 169
 - measurement setup, 168
 - spectrum shape, 166
 - transmitter operation, 166
 - view/trace menu, 168
 - offset frequencies
 - spectrum emission mask, 469, 485, 486, 497
 - offset frequencies auto mode
 - spectrum emission mask, 470, 471, 487
 - offsets & limits
 - offset side, 157
 - relative attenuation, 157
 - offsets and limits
 - limits, 157
 - absolute start level, 158
 - absolute stop level, 158
 - fail mask condition, 158
 - relative start level, 158
 - relative stop level, 158
 - measurement bandwidth, 157
 - offset, 156
 - resolution bandwidth, 157
 - start frequency, 156
 - step frequency, 157
 - stop frequency, 157
 - options
 - loading/deleting, 114
 - options not in instrument
 - memory, 114
 - packing
 - SPECTrum, 502
 - pass/fail test, 281
 - peak EVM limit

- W-CDMA (3GPP) (BTS), 307
- cdma2000 (BTS), 307
- modulation accuracy (rho) (BTS), 307
- terminal modulation accuracy (rho), 314
- personalities
 - currently available, 336
 - selecting, 336, 337
- personality options not in instrument, 114
- phase error
 - amplitude Y scale
 - reference position, 194
 - reference value, 194
 - scale coupling, 194
 - scale per division, 194
- phase error graph
 - amplitude Y scale, 211, 233
 - reference position, 234
 - reference value, 234
 - scale coupling, 234
 - scale per division, 234
- phase error limit
 - cdma2000, 307
 - modulation accuracy (rho), 307
- phase inversion, 415
- phase window, 260
- pilot time offset limit
 - modulation accuracy (rho), 308
 - terminal modulation accuracy (rho), 314
- points/measurement
 - CHPower, 418
- power reference
 - region A through region E, 145
- power stat CCDF
 - span X scale, 239
- power statistic CCDF
 - W-CDMA (3GPP), 304
 - cdma2000, 304
 - store reference, 304
- power statistics CCDF
 - display menu, 239
 - marker menu, 239
 - measurement setup, 238
- power statistics CCDF
 - measurement, 441
 - See also PStat
- power versus time
 - amplitude Y scale, 148
 - changing the display, 147
 - changing the view, 145
 - view/trace selection, 145
 - display key, 147
 - marker key, 149
 - measurements, 141
 - span X scale, 147
 - power vs. time
 - averaging state, 443
 - power vs. time - averaging mode, 444
 - power vs. time - averaging type, 444
 - power vs. time - limit line mask display, 447
 - power vs. time - lower mask
 - relative amplitude levels, 450
 - power vs. time - number of bursts averaged, 443
 - power vs. time - resolution bandwidth, 445
 - power vs. time - trigger source, 456
 - power vs. time - upper mask
 - absolute amplitude levels, 451, 452
 - power vs. time - upper mask
 - relative amplitude levels, 448, 449, 451, 452, 454, 455
 - power vs. time measurement, 371, 443
 - See also PVTime
 - pre-ADC bandpass filter
 - SPECTrum, 507
 - pre-FFT bandwidth, SPECTrum, 506, 507, 508
 - preamble auto detection
 - CDPower, 415
 - RHO, 462
 - preamble length
 - CDPower, 415
 - RHO, 461
 - pre-amplifier
 - attenuator, 438
 - on/off, 438
 - predefined active channel
 - acknowledge channel at W8(4)
 - I, 186, 218
 - data channel at W4(2)
 - Q, 186, 218
 - data rate control channel at W16(8)
 - Q, 186, 218
 - pilot channel at W16(0)
 - I, 186, 218
 - preset measurement offset and interval
 - MAC channel #1, #2, #3, #4, 229
 - full slot, 155
 - half slot, 154
 - idle slot, 154
 - idle slot #1 or #2, 229
 - pilot channel #1 or #2, 229
- presets, 70
- print setup
 - print demodulated bits data, 194
- programming
 - compatibility among PSA modes, 267, 269
 - compatibility, PSA series versus VSA, 270
- query data, 281, 288
- radio
 - device
 - BTS, 71
 - BTS & MS, 71
 - BTS (forward link), 72
 - MS (reverse link), 72
 - real number data format, 332
 - rear panel external trigger
 - delay, 537
 - slope, 538
 - reference channel
 - channel integration bandwidth, 155
 - channel span, 155
 - resolution bandwidth, 155
 - step frequency, 155
 - reference channel resolution
 - bandwidth
 - spectrum emission mask, 466
 - reference channel resolution
 - bandwidth auto mode
 - spectrum emission mask, 466
 - spectrum emission mask, 468
 - reference channel step frequency
 - auto mode list
 - spectrum emission mask, 469
 - reference signal
 - automatic setting, 138
 - average signal, 138
 - lower frequency signal, 138
 - upper frequency signal, 138
 - reference, selecting internal, 427
 - region and limits
 - interval, 144
 - lower mask, 144
 - offset start, 144
 - offset stop, 144
 - power reference on/off, 144
 - region, 144
 - upper mask, 144
 - regions and limits
 - limits, 160
 - region, 159
 - relative attenuation, 160
 - resolution bandwidth, 160
 - start frequency, 159

- step frequency, 159
- stop frequency, 159
- resolution bandwidth
 - automatic mode, 138
 - intermodulation, 429
 - manual mode, 138
- resolution bandwidth state
 - intermodulation, 430
- restart measurement, 335
- results, waveform measurement, 254
- return data, 281, 288
- reverse link coding
 - acknowledge channel, 33
 - data request channel, 33
 - reverse link scrambling, 33
 - reverse rate indication, 33
- rho limit
 - W-CDMA (3GPP) (BTS), 308
 - cdma2000 (BTS), 308
 - modulation accuracy (rho) (BTS), 308
 - terminal modulation accuracy (rho), 314
- rho overall preamble included RHO, 462
- rho result I/Q offset
 - modulation accuracy (rho), 305
 - terminal modulation accuracy (rho), 311
- sampling trace data, 281, 288
- select view
 - terminal modulation accuracy measurement, 328
- signal envelope view
 - signal envelope window, 261
- signal envelope window, 260
 - amplitude Y scale, 261
 - reference position, 261
 - reference value, 261
 - scale coupling, 261
 - scale per division, 261
- single vs. continuous measurement mode, 334
- slot type
 - active slot, 144
 - idle slot, 144
- span
 - CHPower, 418
 - SPECtrum, 513
 - intermodulation, 432
- span C scale
 - scale coupling, 148
- span X scale
 - reference position, 148, 210, 223
 - reference value, 148, 210, 223
 - scale coupling, 210, 223
- scale per division, 147, 210, 223, 239
- spectrum
 - I signal trace, 252
 - Q signal trace, 252
 - all traces, 251
 - amplitude Y scale, 249
 - averaged trace, 251
 - changing the display, 249
 - changing views, 246
 - current trace, 252
 - next window selection, 246
 - span X scale, 249
 - trace display, 251
 - view/trace, 246
 - zoom a window, 246
- spectrum (frequency domain)
 - measurement, 398, 502
 - See also SPECtrum
- spectrum emission mask
 - detector mode, 467
 - measurement interval, 499
 - offset frequencies, 469, 486
 - offset frequencies auto mode, 470, 471, 487
 - offset start frequency, 472, 487
 - offset stop frequency, 473, 475, 488, 490
 - offset stop frequency auto mode, 474, 489
 - power reference, 500
 - relative attenuation, 475, 490
 - setting amplitude levels, 477, 479, 480, 482, 484, 491, 492, 494, 495, 496, 497
 - testing choices, 480, 493
 - trigger source, 500
- spectrum emission mask measurement, 392, 464
 - See also SEM
- spectrum measurement
 - making the measurement, 241
 - method, 241
 - results, 241
- spectrum measurement display, 320, 321, 328, 329
- spectrum normal/invert terminal code domain measurement, 520
- terminal modulation accuracy measurement, 526
- spectrum phase
 - CDPower, 415
- spectrum segment, 163, 164
 - offset, 161
 - all offsets, 161
 - offset A, 161
 - offset E, 161
 - offset side, 161
 - offset or region, 155
- region, 162
 - all regions, 162
 - region A, 163
 - region E, 163
 - regions and limits, 159
- spectrum emission mask, 498, 499
- spectrum type
 - RHO, 462
- spurious emissions and ACP
 - amplitude Y scale, 163
 - display menu, 163
 - measurement setup, 152, 153
 - view/trace, 161
- spurious emissions and ACP measurement, 464
- spurious emissions mask
 - spectrum graph (total power ref), 151
- spurious emissions or ACP marker menu, 164
 - delta reading, 164
 - erase a marker, 164
 - erase all markers, 164
 - function selection, 164
 - marker shape, 164
 - normal reading, 164
 - trace selection, 164
- standard deviation of trace data, 281, 288
- start measurement, 334, 335
- state
 - changing, 411
- store reference
 - power statistic CCDF, 304
- sweep time
 - SPECtrum, 513, 514
 - WAVEform, 534
- symbol power graph
 - amplitude Y scale
 - reference position, 192
 - reference value, 192
 - scale coupling, 193
 - scale per division, 192
 - display, 191
 - composite chip power, 191
 - span X scale, 192
 - reference position, 178, 192
 - reference value, 192
 - scale coupling, 192
 - scale per division, 192
- terminal code domain error limit 1xEV-DO, 312

- terminal code domain
 - measurement
 - ACK channel definition, 516
 - ADC range, 517
 - DRC channel definition, 517
 - I long code mask, 520
 - Pilot channel definition, 517
 - Q long code mask, 520
 - active code channel, 516
 - chip rate, 519
 - data capture time, 518
 - data channel definition, 516
 - spectrum normal/invert, 520
 - trigger source, 519
- terminal code domain power
 - measurement, 401
- terminal modulation accuracy
 - frequency error limit test, 313
- terminal modulation accuracy (rho)
 - ACK channel power gain, 312
 - DRC channel power gain, 313
 - RMS EVM limit, 315
 - RRI limit, 315
 - active code domain power
 - tolerance, 312
 - active set threshold, 311
 - active set threshold mode, 311
 - code domain error limit, 312
 - data channel power gain, 313
 - inactive channel power limit, 313
 - peak EVM limit, 314
 - pilot time offset limit, 314
 - rho limit, 314
 - rho result I/Q offset, 311
- terminal modulation accuracy
 - measurement, 405
 - ACK channel definition, 521
 - ADC range, 522
 - Active Set Threshold level, 524
 - DRC channel definition, 522
 - I long code mask, 526
 - Pilot channel definition, 522
 - Q long code mask, 526
 - active code channel, 521
 - average count, 524
 - averaging state, 524, 525
 - averaging termination control, 524
 - chip rate, 525
 - data channel definition, 521
 - select view, 328
 - spectrum normal/invert, 526
 - trigger source, 526
- test limit
 - OBW, 302
- test limits, 281
 - EVM, 306
 - cdmaOne, 306
- tile the display, 317
- time domain measurement, 408, 528
- time domain measurements, 254
- time offset limit
 - cdma2000, 308
 - modulation accuracy (rho), 308
- time reference
 - burst center, 145
 - burst rise, 145
 - trigger, 145
- trace averaging, 436
- trace data
 - processing, 281, 288
- trace display, 323
- trace format, 332
- trace names for markers, 295
- trace/view selection
 - log envelope graph view, 258
 - magnitude & phase graph view, 258
- transmit band spurs - averaging
 - state, 530
- trigger, 75
 - RF burst signal, 75
 - SPECTrum, 514
 - WAVEform, 534
 - auto time, 536
 - automatic trigger, 75
 - burst level, 541
 - commands, 536
 - delay, 75, 537
 - delay, IF, 540
 - external, 537, 538
 - external front input, 75
 - external rear input, 75
 - frame adjustment, 538, 539
 - frame period, 538
 - frame sync mode, 539
 - frame timer, 76
 - offset, 76
 - period, 76
 - reset offset display, 76
 - synchronizing source, 76
 - holdoff, 540
 - level, 75, 537
 - level, IF, 540
 - on/off, 536
 - power vs. time, 456
 - slope, 75, 538
 - slope, IF, 541
 - timeout, 536
 - trigger holdoff, 75
 - trigger source, 128
- RF burst (wideband), 128
- external front input, 128
- external rear input, 129
- frame clock, 129
- free run (immediate), 128
- power line, 129
- video (IF envelope), 128
- video (envelope) signal, 75
- trigger measurement, 334, 335
- trigger source
 - OBW, 437
 - QPSK EVM, 426
 - Rho, 463
 - W-CDMA, 416
 - cdma2000, 416
 - spectrum emission mask, 500
- terminal code domain
 - measurement, 519
- terminal modulation accuracy
 - measurement, 526
- triggering
 - CHPower, 420
- uninstalling measurement
 - personalities, 114
- upper mask
 - level and on/off, 144
- view PVT data, 318, 319
- view code domain data, 317
- view code domain results, 322
- view commands, 317
- view rho data, 319
- view/trace
 - I/Q error with quad view, 221
 - I/Q measured polar graph, 220
 - I/Q waveforms, 247
 - code domain with quad view
 - marker, 190
 - marker to de-spread, 190
 - linear spectrum and phase graphs, 247
 - result metrics, 221
 - spectrum graph, 246
- view/trace menu
 - I/Q error with quad view, 206, 231
 - I/Q measured polar
 - constellation view, 230
 - I/Q measured polar graph, 204
 - I/Q measured polar vector view, 230
 - I/Q measured with quad view, 207
 - I/Q polar and power graph, 177
 - power graph and metrics, 176
 - power, timing, and phase results, 208
 - result metrics view, 205

view/trace selection

I and Q waveform view, [250](#)

I/Q Waveform view, [258](#)

I/Q polar waveform view, [259](#)

I/Q waveform graph window,
[247](#)

magnitude & phase graph view,
[246](#)

region A through E, [147](#)

rising and falling edge regions,
[147](#)

spectrum linear

linear spectrum window, [249](#)

whole burst waveform, [146](#)

waveform

I/Q waveform view, [261](#)

advanced menu, [257](#)

changing displays, [260](#)

changing views, [258](#)

view/trace selection, [258](#)

making the measurement, [254](#)

method, [254](#)

next window selection, [258](#)

resolution bandwidth, [257](#)

results, [255](#)

span X scale, [260](#)

sweep time, [256](#), [260](#)

using markers, [262](#)

zoom a window, [258](#)

waveform (time domain)

measurement, [408](#), [528](#)

See also WAVEform

waveform measurement

I/Q Polar view, [262](#)

display, [262](#)

zero span measurement, [408](#), [528](#)

zoom the display, [318](#)